

UNITED STATES PATENT AND TRADEMARK OFFICE

BEFORE THE PATENT TRIAL AND APPEAL BOARD

CREE, INC.

Petitioner

v.

OPTOLUM, INC.

Patent Owner

Case No. IPR2017-_____

Patent 6,831,303

DECLARATION OF JIANZHONG JIAO, PH.D.

MAIL STOP PATENT BOARD

Patent Trial and Appeal Board

United States Patent & Trademark Office

P.O. Box 1450

Alexandria, Virginia 22313-1450

I, Dr. Jianzhong Jiao, Ph.D. declare as follows:

I. INTRODUCTION

1. I am over the age of twenty one (21) and am competent to make this Declaration. I reside in the State of California at 750 Van Ness Avenue, Unit 805, San Francisco, CA 94102.

2. I am an independent consultant in light emitting diodes (“LED”) lasers, and lighting technologies.

A. Engagement

3. I have been retained by counsel for Cree, Inc. in the above-captioned Inter Partes Review (“IPR”) matter as an independent technical expert through the agency Teklicon, Inc., 96 N. 3rd Street, Suite 301, San Jose, CA 95112.

4. As part of this engagement, I have been retained to review and evaluate whether certain patents and publications disclose to a person of ordinary skill in the art (“POSA”) the subject matter of specific claims of United States Patent No. 6,831,303 (“the ‘303 patent”) as of the time of the filing date of the ‘303 patent. I expect to testify regarding the matters set forth in this declaration if asked to do so.

5. I am being compensated on an hourly basis for my work performed in connection with this case. I have received no additional compensation for my

work in this case, and my compensation does not depend upon the contents of this report, any testimony I may provide, or the ultimate outcome of the case.

B. Background and Qualifications

6. I received my B.S. degree in Mechanical Engineering from the Beijing Polytechnic University in Beijing, China in 1980. Immediately thereafter, I completed my M.S. degree in Applied Physics at the Beijing Institute of Post and Telecommunications in Beijing, China in 1983. I thereafter attended Rensselaer Polytechnic Institute for graduate studies Physics in 1985. I thereafter received my Ph.D. degree in Electrical Engineering from Northwestern University in Evanston, IL in 1989.

7. I worked at General Motors Corporation from 1989 to 1993 as a Senior Development Engineer on automotive lighting applications including leading and managing R&D projects to implement automotive lighting using LEDs and other technologies.

8. I worked at North American Lighting, Inc. from 1993 to 2007 as a Manager and then General Manager of Engineering Technology on a variety of matters including strategic planning for new technology implementation including LED technology, establishing and managing an engineering team over four departments (Optical Design, Electronic Technologies, Engineering Analysis,

Regulation and Standards), and growth of revenue and expansion of the U.S. customer base.

9. I worked at OSRAM Opto Semiconductors Inc. from 2007 to 2015 as a Director of Regulations and Emerging Technologies on a variety of matters including establishing strategies for LED technology and applications, managing LED technology strategies and implementations in automotive lighting, general illumination, horticulture lighting, displays, medical, defense, and others applications, managing activities relating to LED and lighting regulations and standards, and interfacing with academic and industrial consortium programs on technology development in LEDs and lighting technologies.

10. Since 2015, I have been self-employed as a Consultant in the areas of LEDs, lasers, and lighting technologies for industry, government agencies, academia and professional associations.

11. I am also currently involved in the academic arena through a variety of professional activities. For example, I serve as (1) an Industry Advisory Board Member for the Lighting Enabled Systems & Applications (LESA, formerly Smart Lighting) Engineering Research Center (ERC) (Jan. 2010 – present), (2) an instructor at professional seminars, such as the SAE International (formerly Society of Automotive Engineers) Continuing Education Programs (Mar. 2003 – present), (3) an instructor for short courses, such as for the Society of International

Optical Engineers (Jan. 2009 – present), and (4) an instructor at workshops, such as “Strategies in Light” (May 2011 – present) and “Light Fair International” (May 2010 – present). I have also served as an adjunct professor, an assistant professor, and a teaching/research assistant at several universities in the U.S. and around the world, including the Lawrence Technological University, Purdue University Anderson Campus, Northwestern University, and the Beijing Institute of Posts and Telecommunications.

12. I am currently active in the following Professional Organizations:

SAE International (SAE) (1989- present, currently SAE Fellow Member);
International Society for Optical Engineering (SPIE) (1989-present, currently SPIE Senior Member); Illuminating Engineering Society (IES) (2007-present);
International Commission on Illumination (CIE) (2007, presently CIE – U.S.A. member).

13. I have served in the leadership roles in several U.S. professional associations, trade associations and standardization organizations that are developing LED and LED lighting standards, including: the Plant Growth LED Lighting Committee of the American Society of Agricultural and Biological Engineers (ASABE); the Lighting Standard Committee of SAE; the Testing Procedures Committee of the Illuminating Engineering Society (IES); the

Roadway Lighting Committee of IES, Light Sources Committee of IES; and the Computer Committee of IES.

14. I have received various honors and awards over the years, including: Senior Member of SPIE (2015); SAE Arch T. Colwell Cooperative Engineering Medal (2010); SAE Fellow (2008); SAE Technical Standards Board Outstanding Contribution Award (2008); SAE Forest R. McFarland Award (2007 and 2000); and Excellence in Oral Presentation Award at the SAE 2005 World Congress (2005).

15. I have written about fifty technical papers and articles, and have served as Editor on fifteen books, on LEDs and lighting technologies as listed on my CV attached hereto as Appendix B. I have been invited to deliver numerous speeches and presentations on LEDs and LED lighting at various conferences since 1999 including the following: “LED Lighting Standards and Methods of Measurements,” Strategies in Lights, Anaheim, CA (Feb. 2017); “LED Lighting Standards and Methods of Measurements,” Strategies in Lights, Santa Clara, CA (Feb. 2016); “Methods of Measurements for LEDs and LED Lighting”, Light Fair International, New York, NY (May 2015); “LED Lighting Standards and Methods of Measurements,” Strategies in Lights, Las Vegas, NV (Feb. 2015); “Methods of Measurements for LEDs and LED Lighting”, Light Fair International, Las Vegas, NV (Jun 2014); “LED Lighting Standardization in the U.S.,” CIE 2014 Lighting

Quality & Energy Efficiency, Kuala Lumpur, Malaysia (April 2014); and “LED Lighting Standards and Methods of Measurements,” Strategies in Lights, Santa Clara, CA (Feb. 2014).

16. Additionally, I am an inventor for nine U.S. patents: USP 7,144,141 entitled “Self-Aim Vehicle Light Device”; USP 7,059,754 entitled “Apparatus and Method for Providing a Modular Vehicle Light Device”; USP 6,953,261 entitled “Reflector Apparatus for a Tubular Light Source”; USP D503,004 entitled “Vehicle Fog Lamp”; USP 6,623,132 entitled “Light Coupler Hingedly Attached to a Light Guide for Automotive Lighting”; USP 6,305,813 entitled “Display Device Using a Light Guide for Exterior Automotive Lighting”; USP 6,007,224 entitled “Automotive Headlamp Reflector and Method for its Design”; USP 5,390,265 entitled “Fiber Optic Light Coupler”; USP 5,197,792 entitled “Illuminator Device for a Display Panel.”

17. In the past 7 years, I have served as an expert witness in the following litigations: Case No. 2:13-CV-06383-JD, Dorman Products, Inc. vs. Paccar, Inc.; Case No. CV12-CV-229, Arthur Wolf vs. Indian Motor Company, et al.; Case No. CV08-07078 DDP (VBKx), Grand General Accessories Manufacturing, Inc. vs. United Pacific Industries; Case No. 1:09-CV-07151-RJS, Carlos Collado, et al. vs. Toyota Motor Sales, U.S.A., Inc.; and Case No. 2:10-CV-03113-R-RMC, Carlos Collado, et al. vs. Toyota Motor Sales, U.S.A., Inc.

18. A detailed description of my professional qualifications, including a listing of my specialties/expertise and professional activities, is contained in my curriculum vitae, a copy of which is attached hereto as Appendix B.

C. Basis of My Opinions and Materials Considered

19. In forming my opinions, I have relied upon my education, knowledge and experience with LED technology, lamps, luminaires and other lighting products including those using LED technology. I have also relied upon my education, knowledge and experience with optical design, electronic design, thermal management, and materials for lamps, luminaires, and other lighting products including those using LED technology.

20. For this work, I reviewed and considered the following materials:

- U.S. Patent No. 6,831,303 (“the ‘303 patent”) including the specification and claims;
- the prosecution history of U.S. Patent Application No. 10/430,732, *i.e.*, the prosecution history of the ‘303 patent;
- the prosecution history of related U.S. Patent Application No. 10/156,810 and associated granted U.S. Patent No. 6,573,536 (“the ‘536 patent”), which is the parent of the ‘303 patent;

- the prosecution history of related U.S. Patent Application No. 10/430,696, which was abandoned and which is a sibling of the ‘303 patent;
- the prosecution history of related U.S. Patent Application No. 10/984,366 and associated granted U.S. Patent No. 7,242,028, which is a child of the ‘303 patent;
- the prosecution history of related U.S. Patent Application No. 10/631,027, which was abandoned and which is a child of the ‘303 patent;
- the prosecution history of related U.S. Patent Application No. 10/984,367 and associated granted U.S. Patent No. 7,288,796, which is a family member of the ‘303 patent;
- the prosecution history of related U.S. Patent Application No. 11/116,962, which was abandoned and which is a family member of the ‘303 patent;
- the prosecution history of related U.S. Patent Application No. 11/116,119, which was abandoned and which is a family member of the ‘303 patent;

- the prosecution history of related U.S. Patent Application No. 11/116,966, which was abandoned and which is a family member of the ‘303 patent;
- U.S. Patent No. 6,462,669 (“the ‘669 patent”);
- U.S. Patent Application Publication No. 20020005826 (“the ‘826 publication”);
- U.S. Patent Application Publication No. 20010049893 (“the ‘893 publication”);
- U.S. Patent Application Publication No. 20020191396 (“the ‘396 publication”);
- U.S. Patent No. 6, 220,722 (“the ‘722 patent”);
- U.S. Patent No. 6,682,211 (“the ‘211 patent”);
- U.S. Patent No. 6,425,678 (“the ‘678 patent”);
- U.S. Patent No. 5,998,925 (“the ‘925 patent”);
- U.S. Patent No. 6,848,819 (“the ‘819 patent”);
- U.S. Patent No. 4,296,539 (“the ‘539 patent”);
- U.S. Patent No. 5,949,347 (“the ‘347 patent”).
- U.S. Patent No. 6,979,100 (“the ‘100 patent”);
- U.S. Patent No. 5,806,965 (“the ‘965 patent”);
- U.S. Patent No. 5,785,418 (“the ‘418 patent”);

- U.S. Patent No. 4,729,076 (“the ‘076 patent”);
- U.S. Patent No. 5,528,474 (“the ‘474 patent”);
- U.S. Patent No. 5,632,551 (“the ‘551 patent”);
- U.S. Patent No. 6,517,218 (“the ‘218 patent”).

21. I have also been asked to review the subject matter disclosed by various patents and publications that are prior art to the ‘303 patent, and have been further asked to compare the subject matter disclosed by those patents and publications to claims 1-4 and 6-23 of the ‘303 patent and determine whether those printed publications taught the claimed subject matter to a POSA prior to the effective filing date of the ‘303 patent, which I have been instructed to assume is May 29, 2002 for purposes of my analysis. Documents I have analyzed with regard to their teachings of subject matter claimed in the ‘303 patent are listed below:

- U.S. Patent No. 6, 220,722 (“the ‘722 patent”);
- U.S. Patent No. 6,682,211 (“the ‘211 patent”);
- U.S. Patent No. 6,425,678 (“the ‘678 patent”);
- U.S. Patent No. 6,848,819 (“the ‘819 patent”);
- U.S. Patent No. 4,296,539 (“the ‘539 patent”);
- U.S. Patent No. 5,949,347 (“the ‘347 patent”).

A “List of Exhibits” is also attached hereto as Appendix A.

II. PATENT PRINCIPLES

22. I am an engineer by trade, and the opinions I express in this declaration involve the application of my engineering knowledge and experience to the evaluation of certain prior art with respect to the '303 patent. I am not a lawyer and have not been trained in the law of patents. Therefore, I have requested the attorneys from Jones Day, who represent Cree, to provide me with guidance as to the applicable patent law in this matter. The paragraphs below express my understanding of how I must apply current legal principles related to patent validity to my analysis.

23. It is my understanding that in determining whether a patent claim under post-grant review before the United States Patent Office (PTO) is anticipated or obvious in view of the prior art, the PTO must construe the claim by giving the claim its broadest reasonable interpretation consistent with the specification as the claim terms and specification would be understood by a POSA. It is my understanding that the broadest reasonable interpretation is the plain meaning, *i.e.*, the ordinary and customary meaning, given to the term by a POSA at the time of the invention, taking into account whatever guidance, such as through definitions, may be provided by the written description in the patent, without importing limitations from the specification. For the purposes of this review, I have

construed each claim term in accordance with its plain meaning, *i.e.*, its ordinary and customary meaning under the required broadest reasonable interpretation.

24. It is my understanding that a claim is anticipated under 35 U.S.C. § 102 if each and every limitation of the claim is disclosed in a single prior art reference, either expressly or inherently. I understand inherent disclosure to mean that the claim feature necessarily flows from the disclosure of the prior art reference. I understand that a claim is unpatentable under 35 U.S.C. § 103 if the claimed subject matter as a whole would have been obvious to a POSA at the time of the alleged invention, which I have been instructed to treat at present as the effective filing date of the '303 patent. I also understand that an obviousness analysis takes into account the scope and content of the prior art, the differences between the claimed subject matter and the prior art, and the level of ordinary skill in the art at the time of the invention. Finally, I understand that I must consider any known secondary evidence that might show nonobviousness of the application, such as long felt but unfulfilled need for the claimed invention, failure by others to come up with the claimed invention, commercial success of the claimed invention, praise of the invention by others in the field, unexpected results achieved by the invention, the taking of licenses under the patent by others, expressions of surprise by experts and those skilled in the art at the making of the invention, and the patentee proceeded contrary to the conventional wisdom of the prior art. But the

secondary evidence must be tied specifically to claim features that are argued to be patentable, and not those already in the public domain. I appreciate that secondary considerations must be assessed as part of the overall obviousness analysis (i.e., as opposed to analyzing the prior art, reaching a tentative conclusion, and then assessing whether objective indicia alter that conclusion).

25. Put another way, my understanding is that not all innovations are patentable. Even if a claimed product or method is not explicitly described in its entirety in a single prior art reference, the patent claim will still be denied if the claim would have been obvious to a POSA at the time of the patent application filing.

26. In determining the scope and content of the prior art, it is my understanding that a reference is considered appropriate prior art if it falls within the field of the inventor's endeavor. In addition, a reference is prior art if it is reasonably pertinent to the particular problem with which the inventor was involved. A reference is reasonably pertinent if it logically would have commended itself to an inventor's attention in considering his problem. If a reference relates to the same problem as the claimed invention, that supports use of the reference as prior art in an obviousness analysis.

27. To assess the differences between prior art and the claimed subject matter, it is my understanding that 35 U.S.C. § 103 requires the claimed invention

to be considered as a whole. This “as a whole” assessment requires showing that one of ordinary skill in the art at the time of invention, confronted by the same problems as the inventor and with no knowledge of the claimed invention, would have selected the elements from the prior art and combined them in the claimed manner.

28. In determining whether the subject matter as a whole would have been considered obvious at the time that the patent application was filed, by a POSA, I have been informed of several principles regarding the combination of elements of the prior art. First, a combination of familiar elements according to known methods is likely to be obvious when it yields predictable results. Likewise, combinations involving simple substitution of one known element for another to obtain predictable results, a predictable use of prior art elements according to their established functions, applying a known technique to a known device (method or product) ready for improvement to yield predictable results, and choosing from a finite number of identified, predictable solutions to solve a problem are likely to be obvious. Thus, if a POSA can implement a “predictable variation” in a prior art device, and would see the benefit from doing so, such a variation would be obvious. Also, when there is pressure to solve a problem and there are a finite number of identifiable, predictable solutions, it would be reasonable for a POSA to pursue those options that fall within his or her technical grasp. If such a process

leads to the claimed invention, then the latter is not an innovation, but more the result of ordinary skill and common sense.

29. I also understand that the “teaching, suggestion, or motivation” test is a useful guide in establishing a rationale for combining elements of the prior art. This test poses the question as to whether there is an explicit teaching, suggestion, or motivation in the prior art to combine prior art elements in a way that realizes the claimed invention. Though useful to the obviousness inquiry, I understand that this test should not be treated as a rigid rule. It is not necessary to seek out precise teachings; it is permissible to consider the inferences and creative steps that a POSA (who is considered to have an ordinary level of creativity and is not an “automaton”) would employ.

30. It is my understanding that when interpreting the claims of the ‘303 patent I must do so based on the perspective of one of ordinary skill in the art at the relevant priority date. My understanding is that the earliest claimed priority date of the ‘303 patent is May 29, 2002.

III. TECHNOLOGY BACKGROUND

31. One of the fastest developing lighting technologies today is the light-emitting diode (or LED). A type of solid-state lighting (or SSL), LED uses a semiconductor to convert electricity into light, for which the semiconductor is often small in light emitting area (less than 1 square millimeter). An LED

conventionally includes one or more LED die (alternatively called an LED chip), which are typically packaged in a protective structure called an LED package, which includes electrical connections and possibly an optical element and thermal, mechanical, and electrical interfaces. LEDs conventionally include two types of semiconductor materials which form a junction or active region that emits light, and electrical contacts connected to leads or other electrical connections. The junction is an interface between “p-type” semiconductor material, which has a deficiency of electrons, and an “n-type” semiconductor material, which has an excess of electrons. Electrical contacts connected to the device permit an electrical current to flow through the junction, thereby causing the emission of light in a certain wavelength, *e.g.*, red, orange, blue, ultraviolet (UV) wavelengths, etc.

32. Red (R), green (G), and blue (B) LEDs may be arranged together so that their combined emission is perceived as white light. Alternatively, LEDs may include a phosphor material that absorbs the radiation emitted from the junction and then reemits visible light of a different wavelength than what was absorbed. For example, a GaN-based LED may emit light at blue wavelengths, and phosphor located near the light-emitting region may absorb a portion of that light and may reemit light over a broader range of wavelengths that spans green, yellow, orange and red (depending on the type of phosphor material). The combination of unabsorbed blue light from the LED die and light emitted from the phosphor may

be perceived by the human eye as white. Such phosphor-converted “white” emitting LEDs became commercially available in late 1990’s.

33. Historically, LEDs have been used as light emitting devices for indicators, markers, displays, and other applications ever since LED technology was commercialized in the 1960’s. Shortly thereafter, when the high-brightness LEDs were introduced in the market in 1990’s, this new generation light source was implemented into the illumination and lighting products/applications. Traditional light sources, such as incandescent, high intensity discharge (HID), fluorescent sources, and the like in luminaire assemblies started being replaced with LEDs due to the longer lifetime and energy efficiency.

34. Similar to the other light sources used in the lamps and luminaires, the LEDs function as light emitters. Depending on the end users’ requirements, the LED lamp and luminaire assembly can include any number of combinations of LEDs and other electronic components, such as a control circuitry or a driver. The LEDs and other electronic components are typically assembled onto a printed circuit board (PCB) or a support structure, forming the light source for the lamp and luminaire. Whether the LED is through-hole mounted or surface mounted onto the circuit board or support structure, such assembly has been commonplace in the lighting industry well before the year 2000. Other components normally as part of the lamp and luminaire assembly include optical elements, such as lenses,

reflectors, and the like. As the light source for a lamp and luminaire, the light emitted from the LEDs may be collected, guided or redirected by the optical elements in the lamp and luminaire, which provide the desired light distribution.

35. In the late 1990's high-power LEDs became readily available, and these LEDs generated substantial heat as well as light emission. In fact, during that time frame, approximately 80% of the energy delivered to such high-power LEDs was dissipated as heat at that time frame. As a result, the industry became acutely aware of the need to address heat management in lamps and luminaires made with such LEDs. For example, U.S. Patent No. 5,785,418 to Hochstein ("the '418 patent") filed October 20, 1997, entitled "Thermally protected LED array," discloses an electrically driven LED lamp assembly with a heat sink to transfer heat from a circuit board containing the LEDs. '418 patent, Abstract. U.S. Patent No. 5,528,474 to Roney ("the '474 patent") filed July 18, 1994, entitled "Led array vehicle lamp," discloses a lamp with LEDs mounted to a circuit board and placed in a housing in which the LEDs and circuit boards are embedded in a resin material cured with thermally conductive particles for conducting excess heat to an outer aluminum housing and outer environment. '474 patent, Abstract. U.S. Patent No. 6,517,218 to Hochstein ("the '218 patent") filed December 1, 2000, entitled "LED integrated heat sink," discloses an electrically driven light emitting diode (LED) assembly with a heat sink for conducting heat from the light emitting diodes. '218

patent, Abstract.

36. Generally speaking, the problem of dissipating heat from LEDs in lamps and luminaries involves considerations of materials, geometries or structures, passive mechanisms, and active mechanisms. As an engineering principle, there was a desire to utilize materials that had high thermal conductivity, such as copper alloys, aluminum alloys, and other metal alloys as supports for LEDs since those materials were effective in conducting heat from hotter to cooler regions. Geometries or structures, such as the use of metal heat fins (also called cooling fins) attached to the LED support structures, were also widely used, since fins have extensive surface areas to allow more effective heat dissipation from the metal to the surrounding air. Fins of such type as heat sinks had been used for decades in cooling electronic devices passively to the surrounding air, such as will be described in connection with certain prior art discussed later. The use of fin-type heat sinks reflects a passive mechanism for cooling LEDs, *i.e.*, conducting heat from fins on the LED support structure to the surrounding air. Active mechanisms, such as blowing or forced circulation air or fluid (including liquid other than air), over heat-sink fins and/or over thermally conductive LED support structures was also utilized since it is more effective to extract heat than passive mechanisms.

IV. PERSON OF ORDINARY SKILL IN THE ART

37. I have been informed that “a person of ordinary skill in the relevant field” is a hypothetical person to whom an expert in the relevant field could assign a routine task with reasonable confidence that the task would be successfully carried out. I have been informed that the level of skill in the art is evidenced by prior art references. Based on my education and experience and understanding of relevant prior art at the time the ‘303 patent was effectively filed, a POSA would have possessed a bachelor’s degree in electrical or mechanical engineering or physics (or the equivalent) and at least three years of training and practical experience in lighting or lighting related fields, including good working skills and knowledge related to light emitting diodes (LEDs) and optical, electrical and mechanical designs for lighting applications. Alternatively, a POSA could have a Master’s Degree or a Ph.D. degree in electrical or mechanical engineering or physics (or equivalent) and at least one year of training and practical experience in lighting or lighting related fields, including good working skills and knowledge related to light emitting diodes (LEDs) and optical, electrical and mechanical designs for lighting applications.

38. Based on my experience, I have an understanding of the capabilities of a POSA in the relevant field. I have supervised and directed many such persons over the course of my career. Further, I had those capabilities myself at the time

the '303 patent was effectively filed.

V. OVERVIEW OF THE '303 PATENT

39. The '303 patent (Ex. 1001), entitled "Light Emitting Diode Light Source," discloses a "light source that utilizes light emitting diodes that emit white light" wherein "[t]he diodes are mounted on an elongate member having at least two surfaces upon which the light emitting diodes are mounted." Ex. 1001, '303 Patent, Abstract. The '303 patent also discloses, "The elongate member is thermally conductive and is utilized to cool the light emitting diodes. In the illustrative embodiment, the elongate member is a tubular member through which a heat transfer medium flows." *Id.* Figures 1-3 (reproduced below) illustrate the device disclosed in the '303 patent. "As shown in FIG. 1, a light source 100 . . . includes an elongate thermally conductive member or heat sink 101. Elongate heat sink 101 is formed of a material that provides excellent thermal conductivity." Ex. 1001 at 2:58-62.

40. As shown in Figure 2, "tubular heat sink 101 is hollow and has an interior cavity 103 that includes one or more heat dissipating fins 105." *Id.* at 2:67-3:2. "To improve heat dissipative properties of the light source 100, elongate heat sink 101 is configured to provide convective heat dissipation and cooling." *Id.* at 2:64-67. "In the illustrative embodiment convective cooling is provided by movement of a medium 102 through elongate heat sink. The medium utilized in

the illustrative embodiment is air, but may . . . be a fluid other than air” *Id.* at 3:5-9. “The exterior surface 107 of the elongate heat sink 101 has a plurality of Light Emitting Diodes 109 disposed thereon.” *Id.* at 3:11-12. “Conductive paths 129 are provided to connect LEDs 109 to an electrical connector 111. The conductive paths may be disposed on an electrically insulating layer 131 or layers disposed on exterior surface 107. . . . [T]he conductive paths and insulating layer are provided by means of one or more flexible printed circuits 113 that are permanently disposed on the surface 107.” *Id.* at 3:20-27. “Flexible printed circuit 113 is adhered to the tube 101 with a heat conducting epoxy to aid in transmission of heat from the LEDs 109 to the tube 101.” *Id.* at 3:40-42. “Light source 100 is mounted into a fixture and retained in position by mounting clips 121, 123. . . .” *Id.* at 3:57-58.

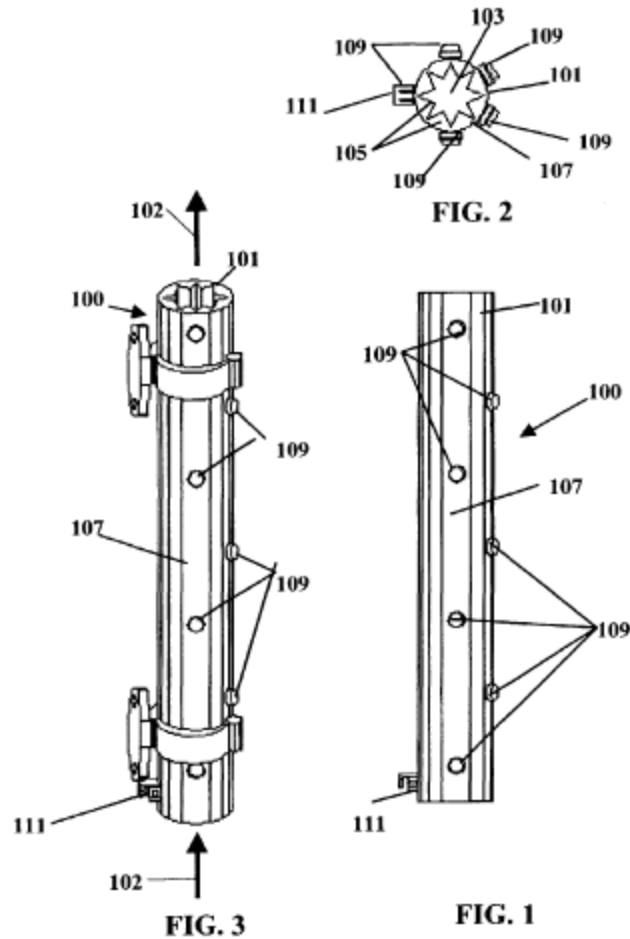

VI. PROSECUTION OF THE ‘303 PATENT AND RELATED APPLICATIONS

41. The ‘303 patent was filed as U.S. Patent Application No. 10/430,732 (“the ‘732 application”) on May 5, 2003, as a continuation of U.S. Patent Application No. 10/156,810 (“the ‘810 application”) filed May 29, 2002, which became U.S. Patent No. 6,573,536 (Ex. 1010, “the ‘536 patent”). Ex. 1001, p. 1. The ‘732 application was filed with 23 claims on May 5, 2003. Ex. 1011, ‘732 Prosecution History at 1-21. In an Office Action dated June 10, 2004, claims 1-22

were rejected under obviousness-type double patenting as being unpatentable over claims 1-23 of the '536 patent (the parent), and claims 22-23 were provisionally rejected for double patenting as claiming the same invention of claims 32-33 of U.S. Patent Application No. 10/430,696 ("the '696 application"). Ex. 1011 at 54-60. An Amendment was filed on June 23, 2004 with a Terminal Disclaimer for the '536 patent, and further explaining that conflicting claim 32 of the '696 application was being amended to overcome the provisional double patenting rejection. *Id.* at 64-75. A Notice of Allowance was issued on July 22, 2004. *Id.* at 80-85. Six references were cited by the Examiner as listed on the face of the '303 patent but were not applied in any prior art rejections. *Id.* at 54-60.

42. In the prosecution of the parent application (the '810 application), there was activity relevant to the claims of the '303 patent. The '810 application was filed with 23 claims on May 29, 2002. Ex. 1012, '810 Prosecution History at 9-28. Claims 1-23 were rejected in an Office Action dated March 6, 2003, over prior art including U.S. Patent No. 6,462, 669 (Ex. 1013, "the '669 patent"), U.S. Patent Application Publication No. 20020005826 (Ex. 1014, "the '826 publication"), U.S. Patent Application Publication No. 20010049893 (Ex. 1015, "the '893 publication"), and U.S. Patent Application Publication No. 20020191396 (Ex. 1016, "the '396 publication"). Ex. 1012 at 29-37. In an Amendment dated March 14, 2003, independent claim 1 at the time was amended

to incorporate the limitations of original claim 3 as follows:

CLAIM 1. (Currently Amended) A light source comprising:
an elongate thermally conductive member having an outer surface;
a plurality of light emitting diodes carried on said elongate member outer surface at least some of said light emitting diodes being disposed in a first plane and others of said light emitting diodes being disposed in a second plane not coextensive with said first plane;
electrical conductors carried by said elongate thermally conductive member and connected to said plurality of light emitting diodes to supply electrical power thereto; and
[whereby] said elongate thermally conductive member being configured to [conducts] conduct heat away from said light emitting diodes to fluid contained by said elongate thermally conductive member.

Ex. 1012 at 39 (where brackets indicate deleted text, and underlining indicates added text). A new independent claim, numbered as claim 24, was added in the Amendment, and was the same as amended claim 1 above, except that claim 24 recited “at least one light emitting diodes” instead of “a plurality of light emitting diodes,” and recited “one or more electrical conductors” instead of “electrical conductors.” *Id.* at 41.

43. The Applicant argued that the claimed “elongate thermally conductive

member being configured to conduct heat away from said light emitting diodes to fluid contained by said elongate thermally conductive member” was not disclosed or suggested by the ‘669 patent, the ‘826 publication, the ‘893 publication or the ‘396 publication. Regarding the ‘669 patent, the Applicant stated, “The Examiner's rejection of claims 1-4 based upon the '669 patent is traversed by the amendment to claim 1 to include the limitation ‘said elongate thermally conductive member being configured to conduct heat away from said light emitting diode to fluid contained by said elongate thermally conductive member.’ At no place does the ‘669 patent show, teach or suggest such a structure.” Ex. 1012 at 42.

Regarding the ‘826 publication, the Applicant stated, “Pederson ‘826 fails to show or teach or suggest a structure in having ‘an elongate thermally conductive member’ and that ‘said elongate thermally conductive member being configured to conduct heat away from said light emitting diodes to fluid contained by said elongate thermally conductive member.’” Ex. 1012 at 43. Regarding the ‘893 publication, the Applicant stated, “Maas et al does not show, teach or describe “an elongate thermally conductive member having an outer surface . . . said elongate thermally conductive member being configured to conduct heat away from said light emitting diodes to fluid contained by said elongate thermally conductive member’ as recited in claim 1, as amended.” Ex. 1012 at 43. Regarding the ‘396 publication, the Applicant stated, “As with the other references, at no point does

Reiff et al teach or suggest an ‘elongate thermally conductive member being configured to conduct heat away from said light emitting diodes to fluid contained by said elongate thermally conductive member.’” Ex. 1012 at 44. Based on these arguments and amendments by the Applicant, the pending claims of the ‘810 application were allowed. Independent claim 1 and similar independent claim 24 were allowed on that basis. Ex. 1012 at 47-50.

44. The above described prosecution reveals that the Examiner for the ‘536 patent (i.e., the ‘810 application) and the ‘303 patent considered the broadest claims of the ‘536 patent to be allowable by virtue of the feature of “elongate thermally conductive member being configured to conduct heat away from said light emitting diodes to fluid contained by said elongate thermally conductive member.” However, subsequent prosecution in the patent family revealed that such feature in such combination was already disclosed in the prior art. In U.S. Patent Application No. 10/631,027 (“the ‘027 application”), which was a continuation of the ‘732 application (i.e., the ‘303 patent), claims with substantially similar limitations were prosecuted and rejected over the prior art, and the ‘027 application was eventually abandoned. Ex. 1017 at 1-2.

45. The sole distinction between claims 1 and 2 of the ‘536 patent and claims 1 and 2 of the ‘027 application as filed was the substitution of the phrase “solid state light source” in the ‘027 application for the phrase “light emitting

diodes” in the ‘536 patent claims. *See* Ex. 1017, ‘027 prosecution history, at 400, 389-412; Ex. 1010 at 4:23-53. All the claims of the ‘027 application required the limitations of the “thermally conductive member” being “configured” to conduct heat away from the light sources “to fluid contained by said elongate thermally conductive member.” Ex. 1017 at 400-412.

46. In a March 21, 2006 Office Action, claims 1 and 2 (among others) of the ‘027 application were rejected as being anticipated by U.S. Patent No. 6,848,819 to Arndt et al. (Ex. 1005, “the ‘819 patent”), where the Examiner stated:

The '819 reference discloses . . . an elongate thermally conductive member (generally indicated at 3/1, Fig. 2B, col. 3, line 55, through col. 4, line 61, particularly col. 4, lines 1-23 and lines 41-61) having an outer surface;
at least one solid-state light source (2, "LED", col. 3, lines 55-60, col. 1, lines 5-10) carried on said elongate member outer surface (Fig. 2B);
one or more electrical conductors (electrical conductors, not shown, col. 3, lines 1-17) carried by said elongate member and connected to said at least one solid-state light source to supply electrical power thereto; and
said elongate thermally conductive member being configured to conduct heat away from said at least one solid-state light source to fluid contained by said elongate thermally conductive member (col. 4, lines 41-61).

Ex. 1017 at 140. FIG. 2B of the ‘819 patent is shown below for reference.

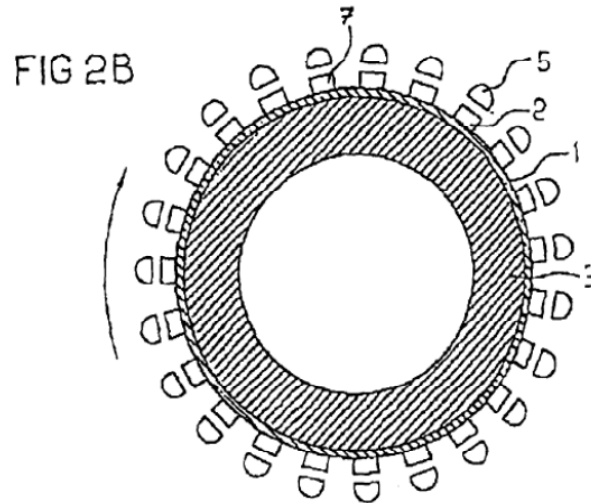

Ex. 1005, FIG. 2B.

47. The examiner repeated the rejection in an Office Action dated November 1, 2006 (Ex. 1017 at 74-76), and further rejected claims 1 and 2 (among others) as additionally obvious in view of the '819 patent in combination with U.S. Patent No. 6,799,864 to Bohler (Ex. 1018, "the '864 patent"). Ex. 1017 at 82-84. The '864 patent was invoked by the Examiner for the teaching of surface mounting high power LEDs (to the extent not disclosed by the '819 patent) on an elongate thermally conductive member as well as for thermally conductive heat-sink fins 64, 64', for which the examiner explained it would have been obvious to apply to the light source of the '819 patent in order to utilize high power LEDs wherein the Examiner stated: "Nevertheless, Bohler, in also disclosing a light source and a radiation emitting source, and in particular in the same effort to reduce heat from operating solid state light sources, teaches that surface-mounting solid state light sources (100) on elongate thermally conductive member ('thermally conductive

spreader' slug 110/ 'thermally conductive core' fins 64', Fig. 3, cols. 1-4, particularly col. 4, lines 1-25) via through-holes (122) in PCB 120 allows for utilizing high-power solid-state LED's." Ex. 1017 at 82-84.

48. Following a response submitted by the Applicant on May 1, 2007 (arguing that "elongate" meant and "having more length than width" and that "thermally conductive member" meant "a structural unit that is a thermal conductor" (Ex. 1017 at 52-54), the Examiner again rejected the then pending claims of the '027 application (including claims 1 and 2) in a June 26, 2007 Office Action based on obviousness over the '819 patent and the '864 patent , explaining that it would have been obvious to a POSA at the time of the invention to make the tubular cooling member 3 of the '819 patent to a have a length more than a width since changes in size and shape have been considered within the level of ordinary skill in the art, wherein the Examiner stated: "[T]he '819 reference fails to disclose: (i) that the metal tubular substrate is an elongate metal tube substrate as required. . . . As for (i), since a change in size and shape is recognized as being within the level of ordinary skill in the art (MPEP 2144.04 [R-1], section IV), a modification to change the tubularly shaped cooling member 3, whose cross-section is shown in Fig. 2B, to have a length more than a width would have been obvious to one of ordinary skill in the art at the time the invention was made." Ex. 1017 at 38-39. In a response dated October 24, 2007, the Applicant again argued

against the pending rejections (*Id.* at 18-30), and on January 11, 2008, the Examiner issued a final office action again rejecting claims 1 and 2 (among others) as obvious over the '819 patent and the '864 patent. *Id.* at 7-15. The '027 application thereafter went abandoned on September 10, 2008. *Id.* at 1-2.

49. Thus, while the Examiner for the '536 patent considered the broadest claim of that application to be allowable by virtue of the feature of “elongate thermally conductive member being configured to conduct heat away from said light emitting diodes to fluid contained by said elongate thermally conductive member,” subsequent prosecution of the '027 application revealed that this feature in combinations substantially similar to those claimed in the '536 patent was obvious in view of the prior art, and that the utilization of heat-sink fins in such combinations was likewise obvious.

VII. SCOPE AND CONTENT OF THE PRIOR ART

A. Overview of the '722 patent

50. The '722 patent (Ex. 1002) is entitled “LED Lamp” and “relates to an LED lamp having a gear column which is connected, at its first end, to a lamp cap and, at its other end, to a substrate.” Ex. 1002, Abstract. As shown in FIG. 1 reproduced below, “This lamp comprises a tubular, hollow gear column (1), which is connected with one end to a lamp cap (2). The other end of the gear column (1) is connected to a substrate (3), which is provided with a number of LEDs (4).” *Id.*

at 3:39-44. “The space within the hollow gear column (1) accommodates the electronic gear necessary for controlling the LEDs (4).” *Id.* at 3:44-45. “The lamp is further provided with an envelope (5) of a synthetic resin, which envelops the gear column (1) and the substrate (3).” *Id.* at 3:47-50.

51. In the example of FIG. 1, “the substrate 3 has the shape of a regular pyramid with four flat faces and is connected to the gear column (1) via a vertex of the pyramid.” *Id.* at 53-55. “The outer surface of the substrate (3) is made of a metal or a metal alloy, thereby enabling good heat conduction from the LEDs (4) to the column (1).” *Id.* at 3:56-58. “Each of the faces of the pyramid [substrate 3] is provided with a number . . . [of] LEDs 4, which are secured to the faces by means of a heat-conducting adhesive.” *Id.* at 3:59-62. In other words, the LEDs 4 are secured to the metal outer surface of the substrate 3 with heat-conducting adhesive, thereby providing good heat conduction from the LEDs 4 to the metal outer surface of the substrate 3. “The LED (4) is also provided with two electrical connections (14). Via these connections, the LED is soldered onto the substrate (3). A heat-conducting adhesive . . . is responsible for a good heat dissipation from the LED to the substrate.” *Id.* at 4:61-65. As would conventionally be understood by a POSA to prevent electrical shorting of electrical connections, “electronics present in the gear column is properly insulated from the metal gear column.” *Id.* at 2:28-29.

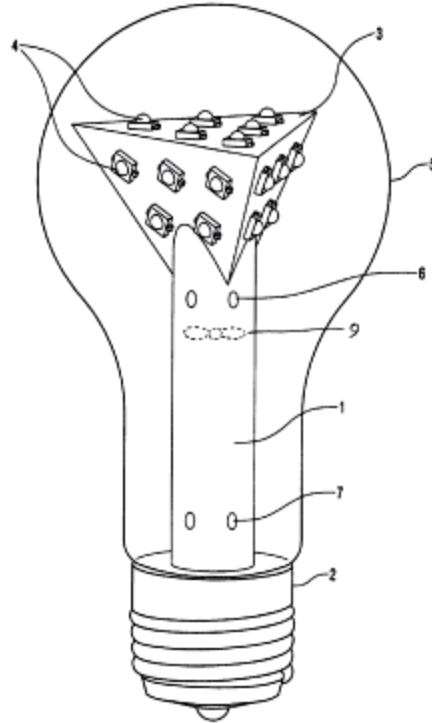

FIG. 1

52. “The outer surface of the gear column (1) of the LED lamp is made of a metal or a metal alloy. This enables a good heat conduction from the substrate (3) to the (metal) lamp cap (2) to be attained.” *Id.* at 3:66-4:2. “In the present example, a copper alloy is used for the column.” *Id.* at 4:2-3. Accordingly, heat is conducted from the LEDs 4 to the metal substrate 3, from the metal substrate 3 to the metal gear column 1, and from the metal gear column 1 to the metal lamp cap 2. “The use of the above-mentioned heat dissipating means enables the LEDs with the relatively high luminous flux to be used without heat problems in a LED lamp of the above-described type.” *Id.* at 4:3-6. “The LED lamp shown in FIG. 1 also includes a fan (9) incorporated in the gear column (1), which fan generates an air flow during operation of the lamp” such that the “air flow leaves the gear column

(1) via holes (6) provided in the gear column, and re-enters the gear column via the holes (7) provided in the gear column.” *Id.* at 4:7-12. As a result, “air flow is led past a substantial number of the LEDs present on the substrate (3),” and “an improved heat dissipation from the substrate and the LEDs is obtained.” *Id.* at 4:13-16. As noted in the ‘722 patent at col. 3:66-4:2, this arrangement permits good heat transfer from the substrate 3 to the metal lamp cap 2, indicating that the lamp cap 2 serves as a heat sink. As explained above, heat is conducted from the LEDs 4 to the metal substrate 3, from the metal substrate 3 to the metal gear column 1, and from the metal gear column 1 to the metal lamp cap 2. Moreover, as explained above, the hollow tubular structure of gear column 1 and the fan 9 with holes 6, 7 provide circulation of air within the lamp and within the gear column 1, such that heat transferred from the LEDs 4 to the substrate 3 and to the gear column 1 can further be transferred to air contained by the gear column 1 and air within the lamp, which further facilitates heat dissipation from the LEDs 4.

B. Overview of the ‘211 patent

53. The ‘211 patent (Ex. 1003) is entitled “Replaceable LED Lamp Capsule” and relates to “an LED chip lamp system [that] comprises a replaceable LED lamp capsule 10 that fits in a reflector 12 and lens 14 housing” where “LED chips may be arranged directly on the surface of a replaceable lamp capsule.” Ex. 1003 at 2:22-24, Abstract. As shown in the example of FIG. 1 reproduced below,

“the replaceable LED lamp capsule 10 comprises a support 16, for one or more LED chips 22,” where the “support 16 is formed from a material with high heat conductivity, such as a metal.” *Id.* at 2:24-26, 36-37. “The preferred support 16 has an umbrella or mushroom like shape with a head 18 portion and a base 20 portion. The head 18 and base 20 portions may be aspects of a single piece or may be separately formed . . . [and] coupled to enable good heat conduction from the supported LED’s 22.” *Id.* at 2:37-43. “For example, head 18 and base 20 may each be formed from metal and then screwed or otherwise joined together.” *Id.* at 2:43-45.

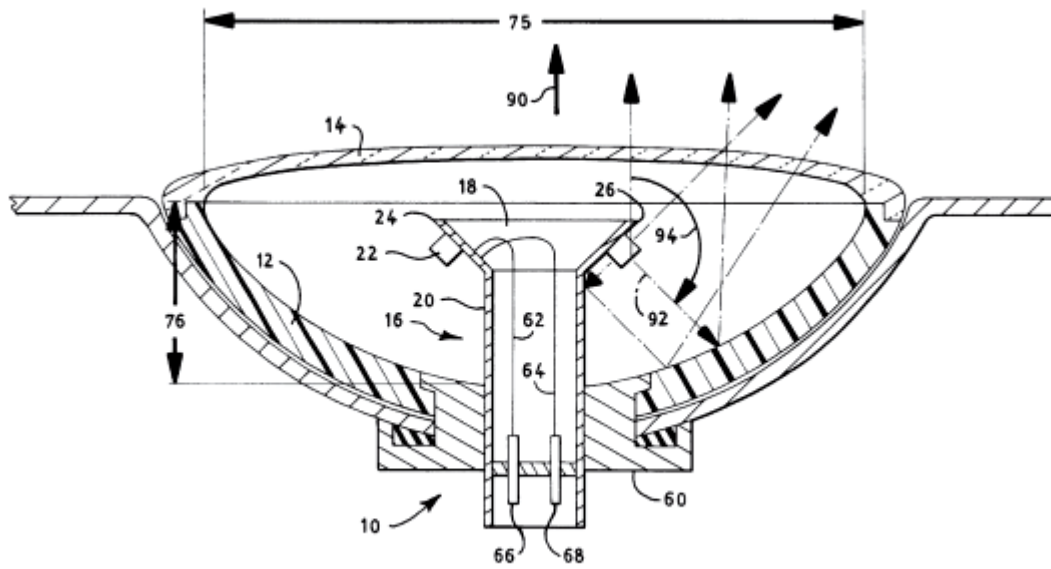

FIG. 1

54. “The head 18 provides a surface to mount LED chips 22 on so as to generally face away from the field to be illuminated and towards the base 20 or reflector 12.” *Id.* at 2:46-48. “A series circuit for the LED chips may be formed

directly on the surface of the head 18. An appropriate pattern of dielectric layers and conductive lines may be laid out on the surface 26 of the support 16 generally, head 18 or base 20 creating a series of coupling regions or pads for the individual LED chips 22 interlinked by electrical supply lines.” *Id.* at 2:66-3:4. “[T]he support 16 is made of metal, and has a coupling 60 providing direct metal to metal contact with the vehicle thereby enabling good thermal conduction away from the LED chips 22 to the vehicle.” *Id.* 3:63-67. “In another variation, the base 20 portion may include *on an exterior side cooling fins or other heat dissipating structures exposed on the exterior of the base 20.*” *Id.* at 4:6-9 (emphasis added). “Direct mounting of the LED chips also leads to little or no trapped heat, and the heat that is generated is efficiently conducted away through the support” *Id.* at 5:20-22. “By mounting the LED chips directly on the support 16, a higher total light output may be achieved, than would be possible if the LED chips 22 are packaged in SMT packages. Similarly, by mounting the LED chips on the support 16, a substantial amount of heat is conducted away, thereby preserving the lamp's life.” *Id.* at 6:47-52.

C. Overview of the ‘678 patent

55. The ‘678 patent (Ex. 1004) is entitled “LED Obstruction Lamp” and relates to an “obstruction lamp which replaces conventional incandescent obstruction lamps and which utilizes light emitting diodes (LEDs) in the

illumination unit.” Ex. 1004 at 1:61-64, Abstract. As shown in FIG. 1 reproduced below, “The LED obstruction lamp 10 includes an optical lens 11 mounted on a base 18. The base 18 is typically a metal casting for ruggedness, with good heat dissipation properties.” *Id.* at 3:16-19. “The optical lens 11 houses LED elements,” and a “clamp 17 and gasket secures the lens 11 to the base 18,” which “may be secured to a wire housing 12 by one or more screws 13.” *Id.* at 3:19-24.

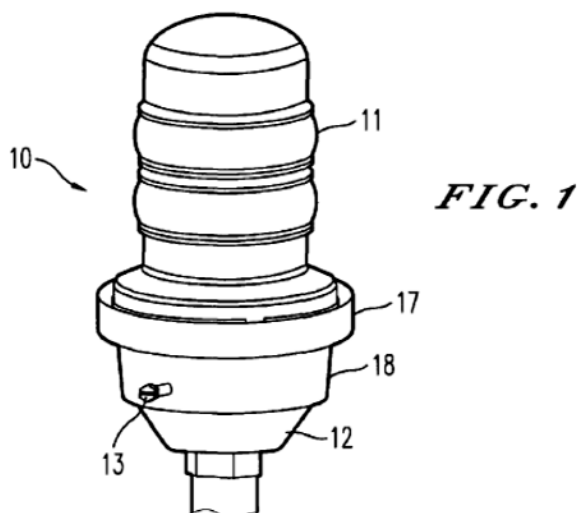

56. As shown in the expanded view of the lamp in FIG. 3 reproduced below, “The internal illuminating unit 30 includes a first plurality of LEDs 31 mounted on the sides of a metal vertical cylinder 35. The LEDs 31 are specifically chosen to be high power LEDs” *Id.* at 3:44-47. “[T]he metal vertical cylinder 35 is specifically designed to be made of a metal which provides a heat sinking for the first plurality of LEDs 31. It is important to provide a heat sinking for the high power LEDs 31 for maximizing life and minimizing light diminution.” *Id.* at 51-55. As shown in FIG. 3, the metal cylinder 35 by inspection has a shape of a

polygon in cross section with multiple faces around its circumference on which the LEDs 31 are mounted.

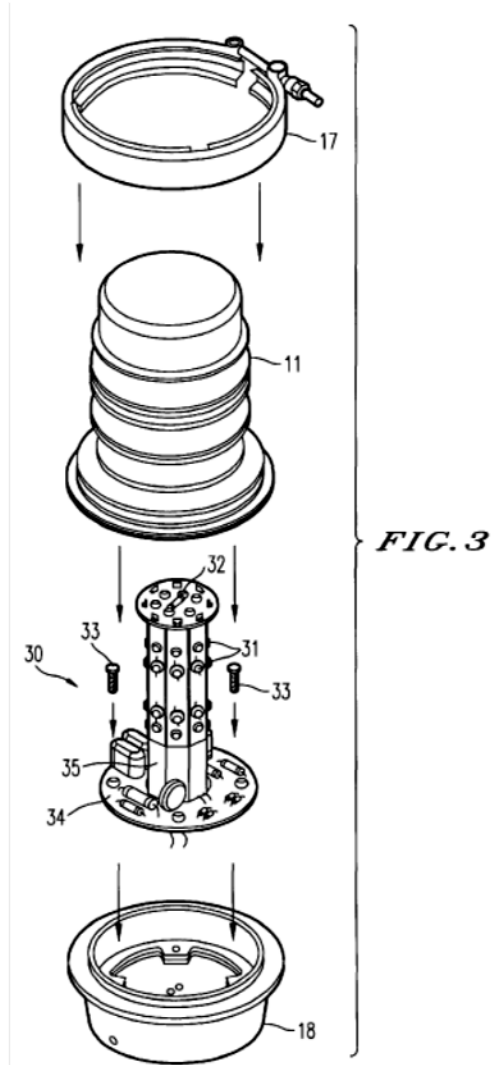

D. Overview of the ‘819 patent

57. The ‘819 patent (Ex. 1005) is entitled “Light-Emitting Diode Arrangement” and describes an “LED array surface-mounted on a circuit board and applied to a cooling member, such that any generated heat is optimally eliminated.” Ex. 1005 at Abstract. As illustrated in FIG. 2B reproduced below, “A flexible printed circuit board 1 such as a flex board that is provided with an array

of LEDs 2 is then laminated onto the cooling member 3.” *Id.* at 4:29-32, FIG. 2B.

“The printed circuit board 1 is laminated onto a cooling member 3 with a thermally conductive adhesive 6, a thermally conductive paste 6 or a thermally conductive film 6, said cooling member 3 being composed of a cooling plate or being fabricated of some other metal such as copper or aluminum, and thus exhibiting a high thermal conductivity.” *Id.* at 4:2-8. “For bundling the emitted light, the LEDs 2 can be provided with lenses 5. . . . As desired, the cylindrical cooling member 3 can also have a gas, such as air or a liquid coolant, flowing through it for further improvement of the heat elimination.” *Id.* at 4:55-61.

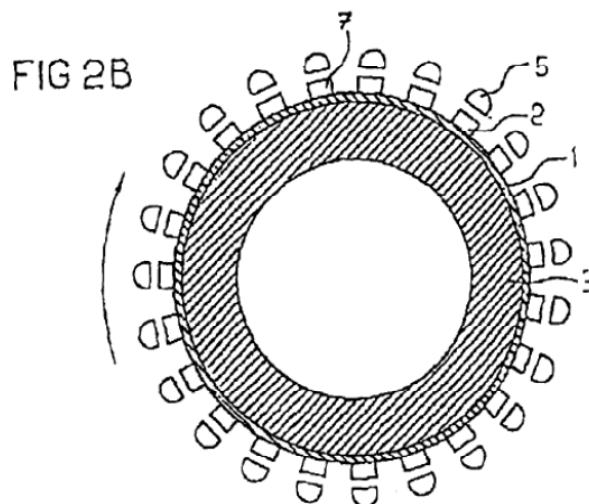

E. Overview of the ‘539 patent

58. The ‘539 patent (Ex. 1006) is entitled “Heat Transfer Tubing For Natural Gas Evaporator” and “relates to heat transfer tubes with improved heat transfer performances, assemblies of such tubes and a method for manufacturing such tubes and tube assemblies.” Ex. 1006 at 1:12-14. As shown in FIGS. 3 and 7

reproduced below, “the tube 1 includes a tubular body 3 having an opposed pair of planar members 2a and 2b each projecting outwardly from its peripheral wall and radially with respect to its longitudinal axis and extending longitudinally along the axis and an internal fin element 4.” *Id.* at 4:8-13. As described in the ‘539 patent, “the planar members 2a and 2b as well as the tubular body 3 are provided with a multiplicity of external flutes 6 running in parallel with the longitudinal axis of the tube to provide an extended external effective heat transfer area . . .” whereby “the utilization of the face and reverse sides of fin members constituting the internal fin element 4 provide effective heat transfer areas and the provision of external flutes 6 on the exterior surfaces of tubular body 3 and planar members 2a, 2b for additional effective heat transfer areas, taken together, result in an outstanding heat transfer performance.” *Id.* at 7:7-18. “The tubular body 3 is most generally formed by *extrusion of aluminum alloy* together with a pair of planar members 2a and 2b *as a single integral unit and when external fins 6 are substantially triangular* as in this invention, the desired product can be *easily obtained by the extrusion technique* using an external die provided with grooves configured to be substantially triangular.” *Id.* at 7:59-66 (emphasis added).

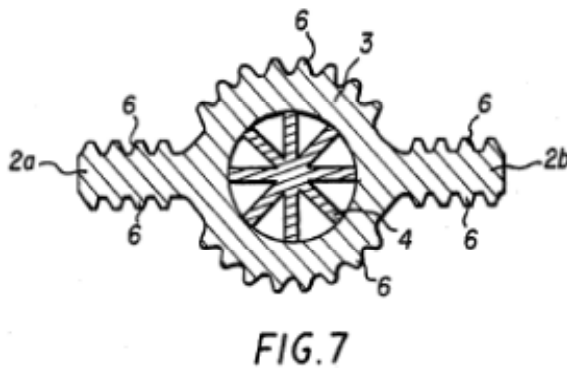
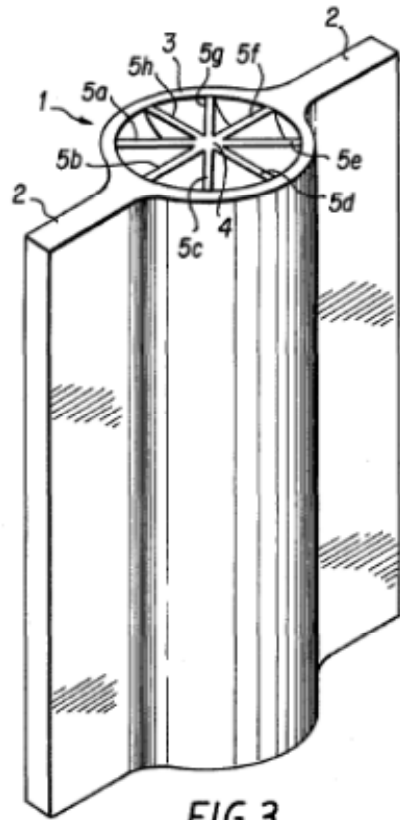

F. Overview of the ‘347 patent

59. The ‘347 patent (Ex. 1007) is entitled “Light Emitting Diode Retrofitting Lamps for Illuminated Signs” and describes lamps with LEDs as illumination sources that are “fitted with any one of the common incandescent lamp bases for use as retrofit lamps” Ex. 1007, Abstract. The ‘347 patent

describes variety LED arrays, such as those illustrated in FIGS. 3C, 5C and 7C. The '347 patent discloses that “[t]he lamp 20 includes a pair of linear arrays of light emitting diodes (LEDs) 22 preferably mounted on a pair of PC boards 24. The PC boards are connected together to form a lamp frame 26 that defines a U-shaped front face 27 on which the pair of LED arrays are mounted.” *Id.* at 3:64-4:1. “The front surface 27 may be formed from, or *coated with, a reflective material*. This configuration *results in lamp 20 evenly illuminating an area* of the adjacent sign face that is significantly wider than the width of the lamp itself.” *Id.* at 4:17-21 (emphasis added). Regarding FIG. 5C embodiment, the '347 patent also states, “The front/back faces 27/53 may be formed from, or coated with, a reflective material.” *Id.* at 5:33-35. Regarding FIG. 7C embodiment, the '347 patent also states, “Front/rear faces 58/62 may be formed from, or coated with, a reflective material. This embodiment *brightly and evenly illuminates* two opposing faces” *Id.* at 5:63-67 (emphasis added). Thus, the '347 patent teaches use of a reflective coating on the surface supporting LEDs to provide bright and even illumination.

VIII. CLAIM CONSTRUCTION

60. Counsel for Petitioner Cree has provided me with their proposals for the broadest reasonable interpretation (BRI) claim constructions for the terms listed below. I concur with those proposed BRI constructions for the reasons

explained below.

61. Elongate: The term “elongate” should be interpreted under the BRI to mean “having more length than width.” This interpretation represents the plain meaning of the term in the context of the specification, *e.g.*, such as illustrated by elongate heat sink 101 in FIGS. 1, 3 and 4 of the ‘303 patent. Moreover, the patentee asserted this definition during prosecution of a related family member application. *See* Ex. 1017, ‘027 prosecution history, at 48, 52-53. In addition, that interpretation was ultimately adopted by the Examiner: “[T]he ‘819 reference . . . fails to disclose: (i) that the metal tube is an elongate metal tube, *i.e.*, a metal tube having more length than width as defined by Applicant” *Id.* at 36.

62. Thermally conductive member: The term “thermally conductive member” should be interpreted under the BRI to mean a “structural unit that is thermally conductive.” This interpretation represents the plain meaning of the term in the context of the specification (*e.g.*, such as illustrated by elongate heat sink 101 in FIGS. 1, 3 and 4 of the ‘303 patent). Moreover, the patentee asserted a similar definition, namely, “structural unit that is a thermal conductor,” during prosecution of a related family member application. *See* Ex. 1017, ‘027 prosecution history, at 48, 50-54. However, it is my opinion that the patentee’s proposed definition is too narrow to the extent that it suggests that the thermally conductive member should be made of a single material. In my opinion, a POSA

would not believe such a requirement to be necessary based on the plain language of the claim term read in light of the '303 patent. The claim term simply requires a structural unit that is thermally conductive.

63. Heat dissipation protrusions: The term “heat dissipation protrusions” should be interpreted under the BRI to mean “protrusions that dissipate heat.” This interpretation represents the plain meaning of the term in the context of the specification, which uses the term “fins” more narrowly than “protrusions.” This indicates that the term “protrusions” is a broader term than “heat fins.” *See, e.g.*, Ex. 1001 at 1:65-67, 3:1-5.

IX. SUMMARY OF OPINIONS

64. Based on my review of the '303 patent, its prosecution history, prosecution histories in certain related family applications, and the patents and publications listed above, it is my opinion that the subject matter of claims 1-4 and 6-23 of the '303 patent was, as of the effective filing date of the '303 patent, unpatentable as either anticipated or obvious in view of various prior art references, the grounds for which are listed and explained below.

X. UNPATENTABILITY OF CLAIMS 1-4 AND 6-23

65. In the paragraphs below, I explain the bases of my opinion that claims 1-4 and 6-23 of the '303 patent are unpatentable. A summary chart of the grounds of unpatentability are presented below:

- Ground 1: Claims 1 and 19 are anticipated by the '722 patent (Ex. 1002).
- Ground 2: Claims 1 and 19 are obvious in view of the '722 patent (Ex. 1002) and the '211 patent (Ex. 1003).
- Ground 3: Claims 2-4, 6-9, and 14-18 are anticipated by the '722 patent (Ex. 1002).
- Ground 4: Claims 2-4, 6-9, and 14-18 are obvious in view of the '722 patent (Ex. 1002) and the '211 patent (Ex. 1003).
- Ground 5: Claims 6-8 are obvious in view of the '722 patent (Ex. 1002) in view of the '678 patent (Ex. 1004).
- Ground 6: Claims 6-8 are obvious in view of the '722 patent (Ex. 1002), the '678 patent (Ex. 1004), and the '211 patent (Ex. 1003).
- Ground 7: Claims 10 and 11 are obvious in view of the '722 patent (Ex. 1002), the '819 patent (Ex. 1005) and the '539 patent (Ex. 1006).
- Ground 8: Claims 10 and 11 are obvious in view of the '722 patent (Ex. 1002), the '819 patent (Ex. 1005), the '539 patent (Ex. 1006), and the '211 patent (Ex. 1003).
- Ground 9: Claims 12 and 13 are obvious in view of the '722 patent (Ex. 1002), the '819 patent (Ex. 1005), and the '539 patent (Ex. 1006).

- Ground 10: Claims 12 and 13 are obvious in view of the ‘722 patent (Ex. 1002), the ‘819 patent (Ex. 1005), the ‘539 patent (Ex. 1006), and the ‘211 patent (Ex. 1003).
- Ground 11: Claims 12 and 13 are obvious in view of the ‘722 patent (Ex. 1002), the ‘819 patent (Ex. 1005), the ‘539 patent (Ex. 1006), and the ‘678 patent (Ex. 1004).
- Ground 12: Claims 12 and 13 are obvious in view of the ‘722 patent (Ex. 1002), the ‘819 patent (Ex. 1005), the ‘539 patent (Ex. 1006), the ‘678 patent (Ex. 1004), and the ‘211 patent (Ex. 1003).
- Ground 13: Claims 20 and 21 are anticipated by the ‘722 patent (Ex. 1002).
- Ground 14: Claim 22 is anticipated by the ‘722 patent (Ex. 1002).
- Ground 15: Claim 22 is obvious in view of the ‘722 patent (Ex. 1002) in combination with the ‘347 patent (Ex. 1007).
- Ground 16: Claim 23 is obvious in view of the ‘722 patent (Ex. 1002) in combination with the ‘347 patent (Ex. 1007).

A. Independent claims 1 and 19 are anticipated by the ‘722 patent (Ground 1)

66. Independent claims 1 and 19 are anticipated by the ‘722 patent (Ex. 1002) as explained below. A claim chart is also presented at the end of Section B

below to summarize the analysis with reference to each of the claim elements.

“A light source comprising”

67. Claims 1 and 19 each recite “A light source” in the preambles thereof. The ‘722 patent discloses this subject matter, *e.g.*: “These and other objects of the invention are achieved by a LED lamp....” Ex. 1002 at 1:40-41. *See also* FIGS. 1 and 2 of the ‘722 patent, which illustrate examples of lamps. Accordingly, the ‘722 patent discloses this subject matter.

“An elongate thermally conductive member having an outer surface”

68. Claims 1 and 19 each recite “an elongate thermally conductive member having an outer surface.” The ‘722 patent discloses an elongate thermally conductive member having an outer surface, *e.g.*, via the combination of substrate 3, gear column 1, and lamp cap 2, as shown in the example of FIG. 1 below (annotated):

An elongate thermally conductive member having an outer surface (1+2+3)

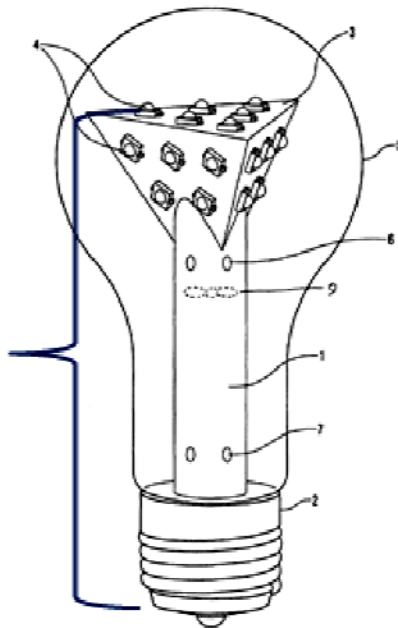

FIG. 1

69. The '722 patent discloses, *e.g.*: “This lamp comprises a tubular, hollow gear column (1), which is connected with one end to a lamp cap (2). The other end of the gear column (1) is connected to a substrate (3), which is provided with a number of LEDs (4).” Ex. 1002 at 3:39-44. The '722 patent also discloses, “A further interesting embodiment of the LED lamp is characterized in that the heat-dissipating means comprise a metal connection between the substrate and the lamp cap.” *Id.* at 2:20-22. *See also* FIG. 2. As labeled in the Figure above, the combination of the substrate 3, gear column 1, and lamp cap 2 plainly has more length than width, even at the widest part. Accordingly, the '722 patent discloses this subject matter.

“A plurality of light emitting diodes [at least one light emitting diode] carried on said elongate member outer surface”

70. Claim 1 recites “a plurality of light emitting diodes carried on said elongate member outer surface,” and claim 19 recites, “at least one light emitting diode carried on said elongate member outer surface.” The ‘722 patent discloses a plurality of (at least one) LEDs 4 carried on said elongate member outer surface, *e.g.*, at an outer surface of substrate 3, as shown in the examples of FIG. 1 and FIG. 2. The ‘722 patent discloses, *e.g.*: “This lamp comprises a tubular, hollow gear column (1), which is connected with one end to a lamp cap (2). The other end of the gear column (1) is connected to a substrate (3), which is provided with a number of LEDs (4).” Ex. 1002 at 3:40-44. The ‘722 patent also discloses, “The outer surface to the substrate (3) is made of metal or a metal alloy, thereby enabling a good heat conduction from the LEDs (4), to the column (1) The outer surface of the gear column (1) of the LED lamp is made of a metal or metal alloy.” Ex. 1002 at 3:56-67. *See also* FIG. 1 and FIG. 2. Thus, the ‘722 patent discloses this subject matter.

“At least some of said light emitting diodes being disposed in a first plane and others of said light emitting diodes being disposed in a second plane not coextensive with said first plane”

71. Claim 1 recites, “at least some of said light emitting diodes being disposed in a first plane and others of said light emitting diodes being disposed in a

second plane not coextensive with said first plane.”¹ The ‘722 patent discloses at least some of said light emitting diodes being disposed in a first plane and others of said light emitting diodes being disposed in a second plane not coextensive with said first plane, as shown in the examples of FIG. 1 and FIG. 2, wherein LEDs 4 by inspection are disposed on different (not coextensive) surface planes of a polyhedron at substrate 3. The ‘722 patent discloses, *e.g.*: “In the example described herein, the substrate (3) has the shape of a regular pyramid with four flat faces.... Each of the faces of the pyramid is provided with a number (five or six) LEDs (4), which are secured to the faces by means of a heat-conducting adhesive.” Ex. 1002 at 3:53-61. The ‘722 patent also discloses, “In the example described with respect to FIG. 2, the substrate (3) is cube-shaped with six flat faces.... Each one of the faces ... is provided with a number (eight or nine) LEDs (4). ...” *Id.* at 4:23-31. Thus, the ‘722 patent discloses this subject matter.

“[One or more] electrical conductors carried by said elongate thermally conductive member and connected to said plurality of light emitting diodes [at least one light emitting diode] to supply electrical power thereto”

72. Claim 1 recites, “electrical conductors carried by said elongate thermally conductive member and connected to said plurality of light emitting

¹ Claim 19 does not require this limitation, but claim 19 is being treated with claim 1 because of other similar claim language.

diodes to supply electrical power thereto,” and claim 19 recites, “one or more electrical conductors carried by said elongate thermally conductive member and connected to said at least one light emitting diode to supply electrical power thereto.” The ‘722 patent discloses one or more electrical conductors carried by said elongate thermally conductive member and connected to said plurality of light emitting diodes (or at least one light emitting diode, claim 19) to supply electrical power thereto, by virtue of electrical connections 14 to the LEDs 4, such as shown in the example of FIGS. 3A and 3B (below):

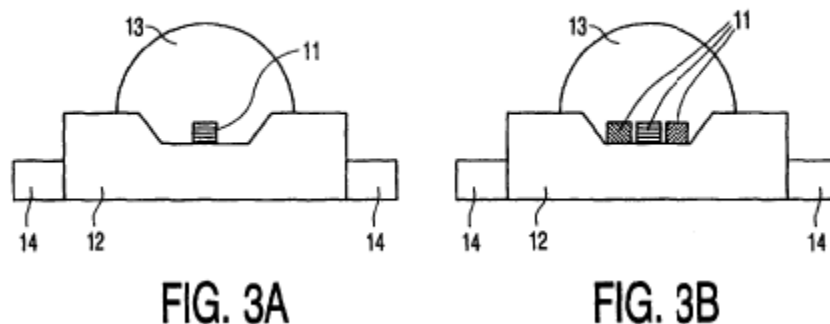

Ex. 1002 at FIGS. 3A, 3B (see also FIGS. 3C and 3D). The ‘722 patent discloses, *e.g.*: “The LED (4) is also provided with two electrical connections (14). Via these connections, the LED is soldered onto the substrate 3.” *Id.* at 4:61-63. The ‘722 patent also states, “The space within the hollow gear column (1) accommodates the electronic gear necessary for controlling the LEDs (4).” *Id.* at 3:44-46. The ‘722 patent further states, “A particular aspect of the invention resides in that the heat-dissipating means remove the heat, generated during

operation of the lamp, from the substrate via the gear column to the lamp cap and the mains supply connected thereto.” *Id.* at 1:54-58. Such “mains” refer to power supply mains, as a POSA would readily understand. In addition, to provide the control of the LEDs 4 with the electronic as described in the ‘722 patent (above), the electrical connections 14 would necessarily supply power to the LEDs 4. Thus, the ‘722 patent discloses this subject matter.

“Said elongate thermally conductive member being configured to conduct heat away from said light emitting diodes [at least one light emitting diode] to fluid contained by said elongate thermally conductive member”

73. Claim 1 recites, “said elongate thermally conductive member being configured to conduct heat away from said light emitting diodes to fluid contained by said elongate thermally conductive member,” and claim 19 recites, “said elongate thermally conductive member being configured to conduct heat away from said at least one light emitting diode to fluid contained by said elongate thermally conductive member.” The ‘722 patent discloses this subject matter, *e.g.*, by virtue of the combination of the metal substrate 3, metal lamp cap 2, and metal gear column 1 being provided with fan 9 and air holes 6, 7, so as to circulate fluid (*e.g.*, air) for dissipating heat away from the LEDs 4 including dissipating heat to fluid (air) contained by the gear column 1. As discussed at paragraphs 50-52 of this Declaration above, the ‘722 patent discloses, *e.g.*: “The outer surface of the substrate (3) is made of a metal or a metal alloy, thereby enabling good heat

conduction from the LEDs (4) to the column (1).” *Id.* at 3:56-58. “Each of the faces of the pyramid [substrate 3] is provided with a number . . . [of] LEDs 4, which are secured to the faces by means of a heat-conducting adhesive.” *Id.* at 3:59-62. In other words, the LEDs 4 are secured to the metal outer surface of the substrate 3 with heat-conducting adhesive, thereby providing good heat conduction from the LEDs 4 to the metal outer surface of the substrate 3.

74. The ‘722 patent also states, “This lamp comprises a tubular, hollow gear column (1), which is connected with one end to a lamp cap (2). The other end of the gear column (1) is connected to a substrate (3), which is provided with a number of LEDs (4).” *Id.* at 3:40-44. “The outer surface of the gear column (1) of the LED lamp is made of a metal or a metal alloy. This enables a good heat conduction from the substrate (3) to the (metal) lamp cap (2) to be attained.” *Id.* at 3:66-4:2. “In the present example, a copper alloy is used for the column.” *Id.* at 4:2-3. Accordingly, with substrate 3, gear column 1, and lamp cap 2 all being metal and joined together as a unit, heat is conducted from the LEDs 4 to the metal substrate 3, from the metal substrate 3 to the metal gear column 1, and from the metal gear column 1 to the metal lamp cap 2.

75. The ‘722 patent also states, “Yet another embodiment of the LED lamp is characterized in that means are incorporated in the column, which are used to generate an air flow in the lamp. Such means, preferably in the form of a fan,

can be used, during operation of the lamp, to generate forced air cooling. In combination with the heat dissipating means, this measure enables good heat dissipation from the gear column and the substrate.” Ex. 1002 at 2:33-39. The ‘722 patent also discloses, “The LED lamp shown in FIG, 1 also includes a fan (9) incorporated in the gear column (1), which fan generates an air flow during operation of the lamp. This air flow leaves the gear column (1) via holes (6) provided in the gear column, and re-enters the gear column via the holes (7) provided in the gear column By virtue thereof, an improved heat dissipation from the substrate and the LEDs is obtained.” *Id.* at 4:7-16.

76. Thus, heat is conducted from the LEDs 4 to the metal substrate 3, from the metal substrate 3 to the metal gear column 1, and from the metal gear column 1 to the metal lamp cap 2. In addition, as explained above based on the express teachings of the ‘722 patent, the hollow tubular structure of gear column 1 and the fan 9 with holes 6, 7 provide circulation of air within the lamp and within the gear column 1, such that heat transferred from the LEDs 4 to the substrate 3 and to the gear column 1 can further be transferred to air contained by the gear column 1, which further facilitates heat dissipation from the LEDs 4. Accordingly, the ‘722 patent discloses this subject matter.

“Said elongate thermally conductive member comprises one or more heat dissipation protrusions”

77. Claims 1 and 19 recite, “said elongate thermally conductive member

comprises one or more heat dissipation protrusions.” The ‘722 patent discloses this subject matter by virtue of the edge portions (highlighting added in red in FIG. 1 below) of adjoining faces of substrate 3 and/or the protruding threads (highlighting added in red in FIG. 1 below) of the lamp cap 2 in FIGS. 1 and 3, as shown below for FIG. 1 of the ‘722 patent with added labeling:

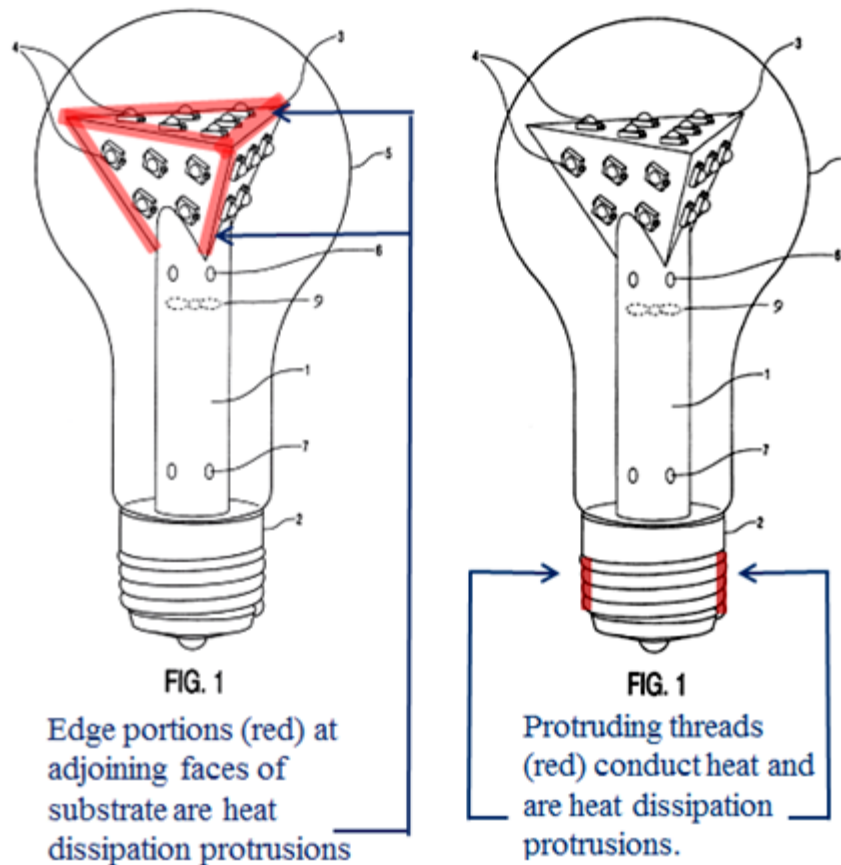

Ex. 1002, FIG. 1 (annotated). The threads (above right) are metal because the lamp cap 2 is metal, and these protruding threads would conduct heat to the socket in which the LED lamp is mounted. For example, the ‘722 patent discloses, *e.g.*, “The outer surface of the substrate (3) is made of metal or a metal alloy, thereby

enabling a good heat conduction from the LEDs (4) to the column (1)... The outer surface of the gear column (1) of the LED lamp is made of a metal or metal alloy. This enables a good heat conduction from the substrate (3) to the (metal) lamp cap (2) to be attained.” Ex. 1002 at 3:56-4:2.

78. In addition, or alternatively, the edges of the adjoining faces of substrate 3 and the points where the edges intersect (above left figure) protrude from the remainder of the elongated thermally conductive member (1+2+3). Those edges and the points where the edges intersect, in addition to other portions of the substrate 3, dissipate heat to the air that is circulating within the envelope, because the substrate as a whole dissipates heat to circulating air. *See, e.g.*, Ex. 1002 at 4:7-16. For example, the ‘722 patent discloses, “The LED lamp shown in FIG. 1 also includes a fan (9) incorporated in the gear column (1), which fan generates an air flow during operation of the lamp.... By virtue thereof, an improved heat dissipation from the substrate and the LEDs is obtained.” *Id.* at 4:7-16. Indeed, the edges of adjoining faces of the substrate 3 are triangularly shaped similar to the heat dissipation protrusions disclosed in the ‘303 patent as shown below, where an annotated version of FIG. 2 of the ‘303 patent is shown on the right, and an annotated view of a portion of FIG. 1 of the ‘722 patent is shown on the left, with one triangularly shaped heat dissipation protrusion for each highlighted in red.

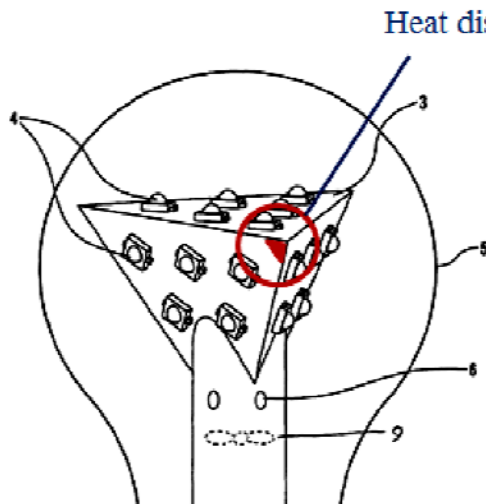

FIG. 1 '722 patent (annotated)

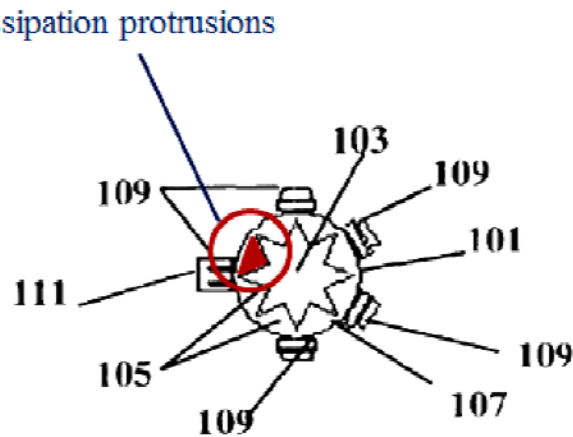

FIG. 2 '303 patent (annotated)

79. In either case, the edges of adjoining faces of substrate 3 and/or the protruding threads of the lamp cap 2 are protrusions that dissipate heat as explained above, and therefore satisfy this claim limitation. Thus, the '722 patent discloses this subject matter. Accordingly, claims 1 and 19 are anticipated for at least these reasons.

B. Independent claims 1 and 19 are obvious in view of the '722 patent and the '211 patent (Ground 2)

80. If the Patent Trial and Appeal Board ("PTAB") finds that the '722 patent does not expressly disclose the claimed heat dissipation protrusions on the surface of the elongated thermally conductive member, then claims 1 and 19 are at least obvious in of the '722 patent in combination with the '211 patent. In this regard, the '211 patent expressly discloses the placement of cooling fins on an exterior (outer surface) of a hollow, metal base portion 20 of an elongated,

thermally conductive metal support 16 to further enhance heat dissipation for cooling LEDs mounted on the metal support 16: “In another variation, the base 20 portion may include on an exterior side cooling fins or other heat dissipating structures exposed on the exterior of the base 20.” Ex. 1003 at 4:6-9. A POSA would have been motivated as of the effective filing date of the ‘303 patent to place the cooling fins of the lamp of the ‘211 patent on the outer surface of the gear column 1 (part of the elongate, thermally conductive member of the lamp of the ‘722 patent), for the purposes of further enhancing heat dissipation away from the gear column 1, substrate 3, and LEDs 4 to air circulating in the envelope 5, including inside the gear column 1 and at the outer surface of the gear column 1, thereby enhancing heat dissipation from the LEDs 4 of the ‘722 patent. The ‘722 and ‘211 patents address common technical issues of managing heat in high illumination LED-based light sources in which a thermally conductive member is formed in the shape of a hollow channel and wherein a fluid (notably air) is utilized to cool the LED light sources. *See, e.g.*, Ex. 1002 at 4:7-16, FIGS. 1, 2; Ex. 1003 at 4:6-9, FIG. 1. In particular, the ‘722 patent states, “The LED lamp shown in FIG. 1 also includes a fan (9) incorporated in the gear column (1), which fan generates an air flow during operation of the lamp. This air flow leaves the gear column (1) via holes (6) provided in the gear column, and re-enters the gear column via the holes (7) provided in the gear column. By suitably shaping and

positioning the holes (6), the air flow is led past a substantial number of the LEDs present on the substrate (3). By virtue thereof, an improved heat dissipation from the substrate and the LEDs is obtained.” Ex. 1002 at 4:7-16. And as noted above, the ‘211 patent states, “In another variation, the base 20 portion may include on an exterior side cooling fins or other heat dissipating structures exposed on the exterior of the base 20.” Ex. 1003 at 4:6-9.

81. Accordingly, as of the effective filing date of the ‘303 patent, a POSA would have been motivated to apply the external cooling fins of the ‘211 patent or similar protrusion structures to the outer surface of the gear column 1 of the ‘722 patent in view of the express teachings of the ‘211 patent, which expressly discloses exterior cooling fins being mounted on an outer surface of an elongate thermally conductive member for enhancing the heat dissipation away from LEDs, which improves the lamp's life by reducing junction temperatures that may otherwise lead to LED degradation or failures, and maintains a total light output that may be achieved. Ex. 1003 at 4:6-9, 6:47-52, 5:6-31. A pictorial illustration with added labeling is shown below.

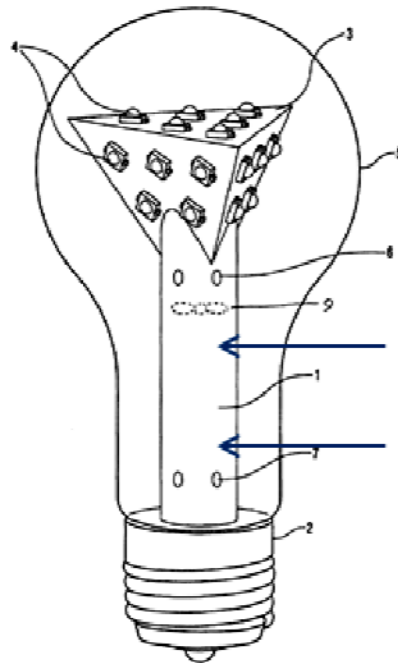

Provide cooling fins to outer surface of gear column 1, per column 1, per teachings of the '211 patent. (E.g., Ex. 1003 at 4:6-9.)

FIG. 1

82. The systems described in the '722 and '211 patents relate to similar technical issues, and combining their features would have been nothing more than combining known prior art elements according to known methods, with no change in their respective functions, to yield predictable results. The '211 patent and the '722 patent describe a common goal of dissipating heat from LEDs in elongate thermally conductive members as disclosed in each of these patents and further in view of the express disclosure of the '211 patent describing the desirability of enhancing heat dissipation from LEDs in such lamp configurations, to increase lamp lifetimes and reduce LED degradations and failures, by placing cooling fins or similar protrusion structures on an exterior surface of an elongate thermally conductive member on which LEDs are directly mounted. *See, e.g., Ex. 1002 at*

3:56-62, 3:66-4:16; Ex. 1003 at 4:6-9, 6:47-52, 5:6-31. A POSA would reasonably have expected such a modification of the lamp of the ‘722 patent to be successful for at least the following reasons: 1) the addition of cooling fins or similar protrusion structures to the gear column 1 would have been a straight forward modification easily made to the lamp of the ‘722 patent, and 2) the ‘722 patent describes air flow within the gear column 1 and the envelope 5 via fan 9 and holes 6, 7, which would have been able to effectuate enhanced cooling provided by such cooling fins placed on the outer surface of the gear column 1.

83. A claim chart is presented below showing where each limitation of claims 1 and 19 is found in the references, either as anticipated by the ‘722 patent or obvious in view of the combination of the ‘722 patent and the ‘211 patent.

CLAIMS 1 and 19 – Anticipation and Obviousness

Claim Element	Prior Art Teaching
<u>Claims 1 and 19</u> A light source comprising:	Ex. 1002 (‘722 patent) at 1:40-41. “These and other objects of the invention are achieved by a LED lamp...”
<u>Claims 1 and 19</u> an elongate thermally conductive member having an outer surface;	Ex. 1002 (‘722 patent) at 3:39-44. “This lamp comprises a tubular, hollow gear column (1), which is connected with one end to a lamp cap (2). The other end of the gear column (1) is connected to a substrate (3), which is provided with a number of LEDs (4).” Ex. 1002 (‘722 patent) 2:20-22. “A further interesting embodiment of the LED lamp is characterized in that the heat-dissipating means

Claim Element	Prior Art Teaching
	<p>comprise a metal connection between the substrate and the lamp cap.”</p> <p>Ex. 1002 (‘722 patent) at 3:56-4:2. “The outer surface to the substrate (3) is made of metal or a metal alloy, thereby enabling a good heat conduction from the LEDs (4) to the column (1)... The outer surface of the gear column (1) of the LED lamp is made of a metal or metal alloy. This enables a good heat conduction from the substrate (3) to the (metal) lamp cap (2) to be attained.”</p>
<p><u>Claim 1</u> a plurality of light emitting diodes carried on said elongate member outer surface</p> <p><u>Claim 19</u> at least one light emitting diode carried on said elongate member outer surface;</p>	<p>Ex. 1002 (‘722 patent) at 3:40-44. “This lamp comprises a tubular, hollow gear column (1), which is connected with one end to a lamp cap (2). The other end of the gear column (1) is connected to a substrate (3), which is provided with a number of LEDs (4).” See FIG. 1 and FIG. 2</p>
<p><u>Claim 1</u> at least some of said light emitting diodes being disposed in a first plane and others of said light emitting diodes being disposed in a second plane not coextensive with said first plane;</p>	<p>Ex. 1002 (‘722 patent) at 3:53-61. “In the example described herein, the substrate (3) has the shape of a regular pyramid with four flat faces.... Each of the faces of the pyramid is provided with a number (five or six) LEDs (4), which are secured to the faces by means of a heat-conducting adhesive.”</p> <p>Ex. 1002 (‘722 patent) 4:23-31. “In the example described with respect to FIG. 2, the substrate (3) is cube-shaped with six flat faces.... Each one of the faces ... is provided with a number (eight or nine) LEDs (4). ...”</p>
<p><u>Claim 1</u> electrical conductors carried by said elongate thermally conductive</p>	<p>Ex. 1002 (‘722 patent) at 4:61-63. “The LED (4) is also provided with two electrical connections (14). Via these connections, the LED is soldered onto the substrate 3.”</p>

Claim Element	Prior Art Teaching
<p>member and connected to said plurality of light emitting diodes to supply electrical power thereto; and</p> <p><u>Claim 19</u> one or more electrical conductors carried by said elongate thermally conductive member and connected to said at least one light emitting diode to supply electrical power thereto;</p>	<p>Ex. 1002 ('722 patent) at 3:44-46. "The space within the hollow gear column (1) accommodates the electronic gear necessary for controlling the LEDs (4)."</p> <p>Ex. 1002 ('722 patent) at 1:54-58. "A particular aspect of the invention resides in that the heat-dissipating means remove the heat, generated during operation of the lamp, from the substrate via the gear column to the lamp cap and the mains supply connected thereto."</p>
<p><u>Claim 1</u> said elongate thermally conductive member being configured to conduct heat away from said light emitting diodes to fluid contained by said elongate thermally conductive member;</p> <p><u>Claim 19</u> said elongate thermally conductive member being configured to conduct heat away from said at least one light emitting diode to fluid contained by said elongate thermally conductive member; and</p>	<p>Ex. 1002 ('722 patent) at 3:40-44. "This lamp comprises a tubular, hollow gear column (1), which is connected with one end to a lamp cap (2). The other end of the gear column (1) is connected to a substrate (3), which is provided with a number of LEDs (4)."</p> <p>Ex. 1002 ('722 patent) at 3:56-4:2. "The outer surface of the substrate (3) is made of a metal or a metal alloy, thereby enabling a good heat conduction from the LEDs (4) to the column (1). . . . The outer surface of the gear column (1) of the LED lamp is made of a metal or a metal alloy. This enables a good heat conduction from the substrate (3) to the (metal) lamp cap (2) to be attained."</p> <p>Ex. 1002 ('722 patent) at 2:33-39. "Yet another embodiment of the LED lamp is characterized in that means are incorporated in the column, which are used to generate an air flow in the lamp. Such means, preferably in the form of a fan, can be used, during operation of the lamp, to generate forced air cooling. In combination with the heat dissipating</p>

Claim Element	Prior Art Teaching
	<p>means, this measure enables good heat dissipation from the gear column and the substrate.”</p> <p>Ex. 1002 (‘722 patent) at 4:7-16. “The LED lamp shown in FIG, 1 also includes a fan (9) incorporated in the gear column (1), which fan generates an air flow during operation of the lamp. This air flow leaves the gear column (1) via holes (6) provided in the gear column, and re-enters the gear column via the holes (7) provided in the gear column.... By virtue thereof, an improved heat dissipation from the substrate and the LEDs is obtained.”</p>
<p><u>Claims 1 and 19</u> said elongate thermally conductive member comprises one or more heat dissipation protrusions.</p>	<p><u>Anticipation by Ex. 1002 (‘722 patent):</u> The ‘722 patent discloses heat dissipation protrusions as shown in annotated FIG. 1 below by virtue of the edge portions of adjoining faces of the substrate 3 (or points thereof) (below left, highlighted in red) and/or the protruding threads of metal lamp cap 2 (below right, highlighted in red).</p> <p>Ex. 1002 (‘722 patent) at 3:56-4:2. “The outer surface to the substrate (3) is made of metal or a metal alloy, thereby enabling a good heat conduction from the LEDs (4) to the column (1).... The outer surface of the gear column (1) of the LED lamp is made of a metal or metal alloy. This enables a good heat conduction from the substrate (3) to the (metal) lamp cap (2) to be attained.”</p> <p>Ex. 1002 (‘722 patent) at 4:7-16. “The LED lamp shown in FIG, 1 also includes a fan (9) incorporated in the gear column (1), which fan generates an air flow during operation of the lamp. This air flow leaves the gear column (1) via holes (6) provided in the gear column, and re-enters the gear column via the holes (7) provided in the gear column.... By virtue thereof, an improved heat dissipation from the substrate and the LEDs is obtained.”</p>

Claim Element	Prior Art Teaching
---------------	--------------------

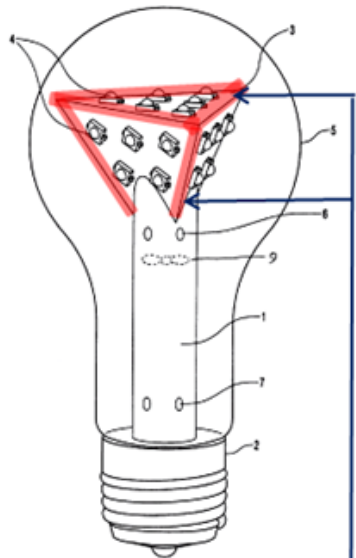

FIG. 1

Edge portions (red) at adjoining faces of substrate are heat dissipation protrusions

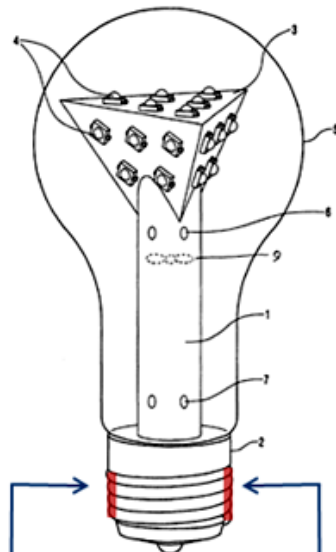

FIG. 1

Protruding threads (red) conduct heat and are heat dissipation protrusions.

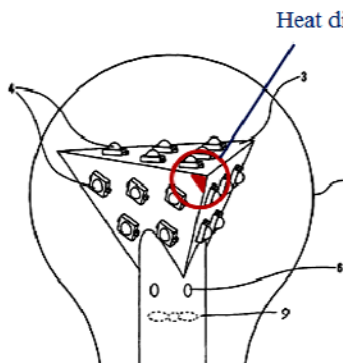

FIG. 1 '722 patent (annotated)

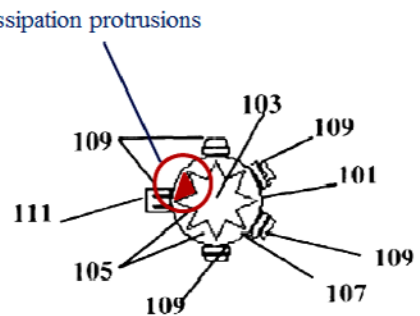
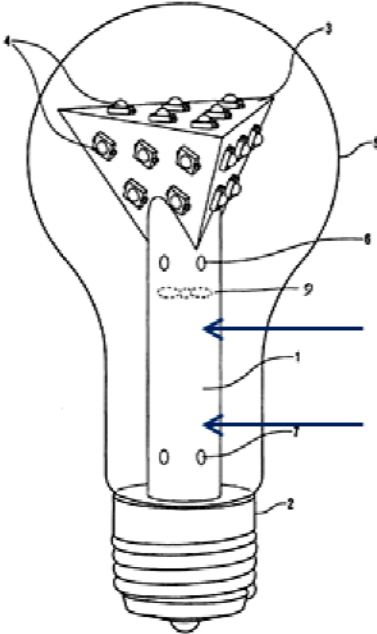

FIG. 2 '303 patent (annotated)

Obviousness in view of Ex. 1002 ('722 patent) and Ex. 1003 ('211 patent):

Ex. 1003 ('211 patent) 4:6-8: "In another variation, the base 20 portion may include on an exterior side cooling fins or other heat dissipating structures exposed on the exterior of the base 20."

Claim Element	Prior Art Teaching
	 <p data-bbox="1088 577 1380 892">Provide cooling fins to outer surface of gear column 1, per teachings of the '211 patent. (E.g., Ex. 1003 at 4:6-9.)</p> <p data-bbox="844 945 909 976">FIG. 1</p>

C. Claim 2 is anticipated by the '722 patent (Ground 3) and obvious in view of the '722 and '211 patents (Ground 4)

84. Claim 2 depends from claim 1 and recites, “at least one of said heat dissipation protrusions being carried on said elongate member outer surface.” This subject matter is anticipated by the '722 patent (Ground 3) considering that (1) the heat dissipating, protruding edges of adjoining faces of the substrate 3, and points where those edges intersect, shown in FIGS. 1 and 2 are part of the elongate thermally conductive member, and/or (2) the lamp cap 2 of the lamp shown in FIGS. 1 and 2 forms part of the elongate thermally conductive member and that the protruding metal threads are part of the lamp cap 2 and dissipate heat, as explained

above for claims 1 and 19. *See, e.g.*, Ex. 1002 at 3:56-4:6 and FIGS. 1 and 2.

85. If the PTAB finds that the protruding edges of adjoining faces of the substrate 3 (or points thereof) or the protruding metal threads on lamp cap 2 of the '722 patent are not heat dissipation protrusions as claimed, then claim 2 is obvious (Ground 4) under the combination of the '722 patent and the '211 patent because it would have been obvious to add the cooling fins or similar protrusion structures of the '211 patent to the outer surface of the gear column 1 of the lamp of the '722 patent to further enhance heat dissipation from the LEDs 4, substrate 3, and gear column 1 as previously explained above for claims 1 and 19. *See, e.g.*, Ex. 1002 at 3:56-62, 3:66-4:16; Ex. 1003 at 4:6-9, 6:47-52, 5:6-31.

D. Claims 3 and 4 are anticipated by the '722 patent (Ground 3) and obvious in view of the '722 and '211 patents (Ground 4)

86. Claim 3 depends from claim 2 and recites, "said elongate thermally conductive member is configured to conduct heat away from said light emitting diodes to fluid proximate said elongate member outer surface." Claim 4 depends from claim 3 and recites, "said fluid proximate said elongate member outer surface comprises air." The '722 patent discloses the subject matter of claims 3 and 4 (Ground 3), *e.g.*, by virtue of the assembly of the substrate 3, lamp cap 2, and gear column 1, which is provided with fan 9 and air holes 6, 7 so as to circulate fluid (air) within the envelope 5 for conducting heat away from the LEDs 4. The '722 patent discloses, *e.g.*: "Yet another embodiment of the LED lamp is characterized

in that means are incorporated in the column, which are used to generate an air flow in the lamp. Such means, preferably in the form of a fan, can be used, during operation of the lamp, to generate forced air cooling. In combination with the heat dissipating means, this measure enables good heat dissipation from the gear column and the substrate.” Ex. 1002 at 2:33-39. The ‘722 patent also discloses, “The LED lamp shown in FIG, 1 also includes a fan (9) incorporated in the gear column (1), which fan generates an air flow during operation of the lamp. This air flow leaves the gear column 1 via holes 6 provided in the gear column, and re-enters the gear column via the holes 7 provided in the gear column.... By virtue thereof, an improved heat dissipation from the substrate and the LEDs is obtained.” *Id.* at 4:7-16. Because air is circulating in the envelope 5, both inside and outside the gear column 1, heat is conducted away from the LEDs 4 to air proximate the outer surface of the elongate thermally conductive member (1+2+3), as indicated by the ‘722 patent: “By virtue thereof, an improved heat dissipation from the substrate and the LEDs is obtained.” *Id.* Thus, the ‘722 patent discloses this subject matter.

87. However, if the PTAB finds that the ‘722 patent does not expressly disclose heat dissipation protrusions as claimed in claim 1, then claims 3 and 4 are obvious (Ground 4) under the combination of the ‘722 patent and the ‘211 patent because, as explained above, it would have been obvious to add the cooling fins of

the '211 patent or similar protrusion structures to the outer surface of the gear column 1 of the lamp of the 722 patent. *See, e.g.*, Ex. 1002 at 3:56-62, 3:66-4:16; Ex. 1003 at 4:6-9, 6:47-52, 5:6-31. A POSA would have readily understood that having fins or similar protrusion structures on the outer surface of a structure that holds LEDs such as the elongate thermally conductive member would conduct heat away from the LEDs to fluid, *e.g.*, air, proximate the elongate member outer surface as required by claims 3 and 4.

E. Claims 6-8 are anticipated by the '722 patent (Ground 3)

88. Claim 6 depends from claim 3 and recites, “said elongate thermally conductive member comprises a tube.” The '722 patent discloses this subject matter at least by virtue of tubular hollow gear column 1 shown in FIGS. 1 and 2. The '722 patent discloses, *e.g.*, “FIG. 1 shows a first embodiment of the invented light emitting [d]iode lamp (LED lamp). This lamp comprises a tubular, hollow gear column (1), which is connected with one end to a lamp cap (2).” Ex. 1002 at 3:38-42. Moreover, a POSA would also reasonably understand the substrate 3 to be hollow and to be an extension of the gear column 1 to which it is attached, such that the gear column 1 and substrate 3 of FIGS. 1 and 3 together may be considered the claimed tube. A POSA would understand the polyhedron substrate 3 to be hollow instead of a solid block of metal because it is referred to as a “substrate,” which indicates a thin planar structure in electrical technology. The '722 patent

states, *e.g.*: “In the example described herein, the substrate (3) has the shape of a regular pyramid with four flat faces and is connected to the gear column (1) via a vertex of the pyramid.” *Id.* at 3:53-55. Considering that a tube conventionally is not required to have a uniform cross section along its length in order to be a “tube” (and the ‘303 patent does not require such), a POSA would consider the substrate 3 to be a tubular extension of the gear column 1. Thus, the ‘722 patent discloses the subject matter of claim 6.

89. Claim 7 depends from claim 6 and recites, “said tube has a cross-section in the shape of a polygon.” Claim 8 depends from claim 6 and recites, “said tube has a cross-section having flat portions.” The ‘722 patent discloses this subject matter at least by virtue of the hollow polygon shaped substrate 3 (as explained above), which forms part of the claimed tube. In this regard, the ‘722 patent discloses, *e.g.*: “In the example described herein, the substrate (3) has the shape of a pyramid with four flat faces. . . . Each of the faces of the pyramid is provided with a number (five or six) LEDs (4), which are secured to the faces by means of a heat-conducting adhesive.” Ex. 1002 at 3:53-62. The ‘722 patent also discloses, “In the example described with respect to FIG. 2, the substrate (3) is cube-shaped with six flat faces. . . . Each one of the faces . . . is provided with a number (eight or nine) LEDs (4). . . .” *Id.* at 4:23-31. Thus, a cross section of the substrate 3 would have a shape of a polygon (as recited in claim 7), and such a

cross section would likewise have flat portions (as recited in claim 8). Thus, the ‘722 patent discloses this subject matter.

F. Claims 6-8 are obvious in view of the ‘722 patent and obvious in view of the ‘722 and ‘211 patents (Ground 4)

90. It is my opinion that a POSA would understand the substrate 3 of the ‘722 patent to be hollow. But if the PTAB finds the substrate 3 is not expressly disclosed as being hollow, then it would have been obvious modification as of effective filing of the ‘303 patent to make the substrate 3 hollow. In particular, it would have been obvious to a POSA to make polyhedron substrate 3 hollow at least because it is referred to as a “substrate,” which indicates a thin planar structure in electrical technology, such that a POSA interested in constructing lamp of the ‘722 patent would reasonably construct the substrate 3 to be hollow. A POSA also would have been motivated to make the substrate 3 hollow for the reasons of (1) minimizing the weight and materials cost of the lamp (to reduce manufacturing and shipping costs), (2) making electrical connections for LEDs and other control electronics in a convenient matter from beneath (inside) the substrate, and (3) enhancing the air circulation to dissipate heat from LEDs 4 (which is the purpose for the holes 6, 7 and fan 9). With the polyhedron substrate 3 of the ‘722 patent being hollow for any of such reasons, the limitations of claims 6-8 are accounted for as explained in Section E immediately above.

91. If the PTAB finds that the ‘722 patent does not expressly disclose heat

dissipation protrusions as claimed in claim 1, then claims 6-8 are obvious under the combination of the '722 patent and the '211 patent because, as explained above, it would have been obvious to add the cooling fins of the '211 patent to the outer surface of the gear column 1 of the lamp of the 722 patent. *See, e.g.*, Ex. 1002 at 3:56-62, 3:66-4:16; Ex. 1003 at 4:6-9, 6:47-52, 5:6-31.

G. Claims 6-8 are obvious in view of the '722 and '678 patents (Ground 5) and obvious in view of the '722, '211 and '678 patents (Ground 6)

92. If the substrate 3 of the '722 patent is not considered to be a part of the claimed tube, then claims 6-8 are at least obvious in view of the '722 patent in combination with the '678 patent. In particular, as noted above, the '678 patent discloses an LED obstruction lamp that can replace incandescent obstruction lamps, stating, "The internal illuminating unit 30 includes a first plurality of LEDs 31 mounted on the sides of a metal vertical cylinder 35. The LEDs 31 are specifically chosen to be high power LEDs. . . ." Ex. 1004. at 3:44-47. "[T]he metal vertical cylinder 35 is specifically designed to be made of a metal which provides a heat sinking for the first plurality of LEDs 31. It is important to provide a heat sinking for the high power LEDs 31 for maximizing life and minimizing light diminution." *Id.* at 51-55. As shown in FIG. 3 below, the metal cylinder 35 by inspection has a shape of a polygon in cross section with multiple faces around its circumference on which the LEDs 31 are mounted. Also, in view of the

configuration of the vertical metal cylinder 35 illustrated in FIG. 3, a POSA would understand the vertical metal cylinder 35 to be hollow. This is because the top of the metal cylinder 35 is configured by inspection as a distinct circular plate on which LEDs 32 are mounted, and a distinct plate as illustrated would be unnecessary if the cylinder were solid (since the upper surface would already be present). In addition, there are no electrical conducting traces evident at the surface of the top plate for electrically connecting the top LEDs 32, which indicates that the required electrical connections are provided to LEDs 32 from beneath the top plate, *i.e.*, from inside the vertical metal cylinder 35, which further indicates that the cylinder 35 is hollow.

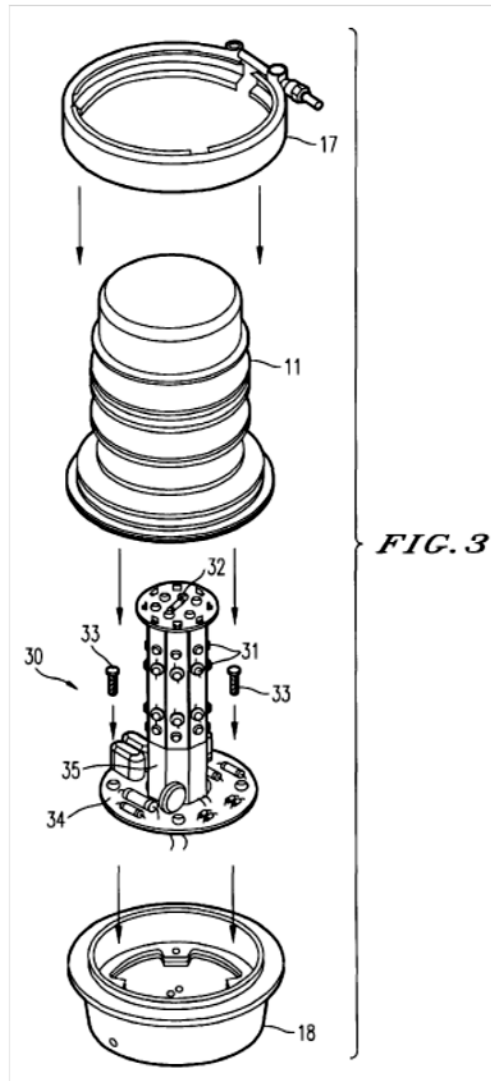

93. As shown in FIG. 3 above, the metal cylinder 35 has a shape of a polygon in cross section with multiple side faces around its circumference on which LEDs 31 are mounted and a top face on which additional LEDs 32 are mounted. A POSA would have recognized the desirability of the simple and uniform shape of the vertical cylinder 35 taught by the '678 patent, which would be easy to manufacture and on which it would be easy to mount LEDs for uniform side and top illumination given the configuration of multiple flat faces

encompassing 360 degrees laterally and a flat mounting face at the top. A POSA would have recognized that it is much easier to mount LEDs on flat surfaces (as in the '678 patent) than on rounded surfaces. A POSA would have been motivated as of the effective filing date of the '303 patent to replace the hollow gear column 1 and polygon substrate 3 of the '722 patent with a simpler vertical, hollow metal tube (consistent with the teaching of *hollow* gear column 1 in the '722 patent) but having the uniform, polygon cross-sectional shape of the metal cylinder 35 and top plate of the '678 patent, with LEDs 4 of the '722 patent mounted on side polygon surfaces and top plate of the modified polygon-shaped, vertical metal tube (arranged like LEDs 31 and 32 are arranged on the vertical metal cylinder 35 of the '678 patent). In addition, a POSA would have motivated to make those modifications while retaining the fan 9 and air holes 6, 7 (FIG. 1 of the '722 patent) inside the resulting vertical, polygon-shaped metal tube that replaces the gear column 1 and the substrate 3 in order to provide the advantageous heat dissipation provided by those components. A POSA would have been motivated to make these modification for the purpose of providing a simpler supporting structure on which to mount LEDs 4, which would have avoided the complexity of the polygon shape substrate 3 and complexity of its attachment to the gear column 1, thereby enhancing the ease of manufacturing and reducing the cost of manufacturing the lamp of the '722 patent. There would have been a reasonable

expectation of success at least because replacement of the gear column 1 and substrate 3 of the '722 patent with a modified vertical metal tube having the outer polygon shape of the metal cylinder 35 of the '678 patent would have been a straightforward reconfiguration of easily manipulated components. Moreover, the resulting vertical metal tube with cross-sectional polygon shape and top plate would have provided a structure with convenient flat surfaces on which to mount LEDs 4 in the modified lamp of the '722 patent as well as an efficient configuration for projecting light both axially (vertically) and radially (horizontally), consistent with omni-directional illumination of the lamp of the '722 patent.

94. With the gear column 1 and substrate 3 of the '722 patent replaced in this way with a simpler, vertical polygon-shaped metal tube and top plate, with an outer shape such as illustrated by the vertical metal cylinder 35 of the '678 patent, the resulting modified lamp would possess features recited in claims 6-8. Specifically, claim 6 depends from claim 3 and recites, "said elongate thermally conductive member comprises a tube." The modified lamp of '722 patent as described above would possess an elongate thermally conductive member comprising the modified vertical metal tube described above in combination with lamp cap 2, and this structure would have possessed the same heat dissipating properties as the combined substrate 3 and gear column 1 because it would be

made using metal as disclosed in the '722 patent for reasons already explained for claim 1 above. The modified lamp structure would also meet all the other limitations of claim 1 (for reasons already explained for claim 1) and claim 3 (for the same reasons already explained above for claim 3). And the modified structure would also meet the limitations of claim 2 at least because the threads on lamp cap 2 are heat dissipation protrusions as previously explained for claims 1 and 2. Claim 7 depends from claim 6 and recites, "said tube has a cross-section in the shape of a polygon." The resulting modified lamp with the vertical metal tube would also meet the limitation of claim 7, because the modified vertical metal tube is intentionally configured to have the polygon cross-sectional shape with multiple flat surfaces like the vertical metal cylinder 35 of the '678 patent. Claim 8 depends from claim 6 and recites, "said tube has a cross-section having flat portions." The resulting modified lamp with a vertical metal tube, intentionally modified to have the polygon cross-sectional shape like the vertical metal cylinder 35 of the '678 patent, likewise meets this limitation of claim 8 because the outer polygon shape intentionally would possess multiple flat surfaces like those illustrated for the vertical metal cylinder 35 of the '678 patent.

95. Thus, the subject matter of claims 6-8 would have been obvious in view of the '722 patent in combination with the '678 patent (Ground 5). However, if the PTAB finds that the '722 patent does not expressly disclose heat dissipation

protrusions as claimed in claim 1 by virtue of the protruding threads on lamp cap 2, then claims 6-8 are obvious under the combination of the '722 patent, the '678 patent, and the '211 patent because, as explained above, it would have been obvious to add the cooling fins of the '211 patent or similar protrusion structures to the outer surface of the gear column 1 of the lamp of the 722 patent (which in this case would be replaced with the modified vertical metal tube containing fan 9 and air holes 6,7, as explained above). *See, e.g.*, Ex. 1002 at 3:56-62, 3:66-4:16; Ex. 1003 at 4:6-9, 6:47-52, 5:6-31.

H. Claims 9 and 14-16 are anticipated by the '722 patent (Ground 3) and obvious in view of the '722 and '211 patents (Ground 4)

96. Claims 9 and 14-16 recite the following:

9. A light source in accordance with claim 1, wherein: said elongate thermally conductive member comprises a channel.

14. A light source in accordance with claim 1, wherein: said fluid is moved in said elongate thermally conductive member.

15. A light source in accordance with claim 1, wherein: said elongate thermally conductive member comprises a thermal transfer media disposed therein.

16. A light source in accordance with claim 15, wherein: said elongate thermally conductive member comprises a flow channel for said thermal transfer media.

97. The '722 patent discloses the subject matter of claims 9 and 14-16

(Ground 3) at least because the tubular hollow gear column 1 shown in FIGS. 1 and 2 is hollow and therefore comprises a channel by virtue of the interior of the hollow gear column 1 (claim 9), wherein fluid (namely, air) is moved in therein (claim 14), which comprises a thermal transfer media (namely, air) disposed therein (claim 15), and which comprises a flow channel for the thermal transfer media (namely, air) (claim 16). The '722 patent discloses, *e.g.*: “This lamp comprises a tubular, hollow gear column (1), which is connected with one end to a lamp cap (2). The other end of the gear column (1) is connected to a substrate (3), which is provided with a number of LEDs (4).” Ex. 1002. at 3:39-44. “Yet another embodiment of the LED lamp is characterized in that means are incorporated in the column, which are used to generate an air flow in the lamp. Such means, preferably in the form of a fan, can be used, during operation of the lamp, to generate forced air cooling. In combination with the heat dissipating means, this measure enables good heat dissipation from the gear column and the substrate.” *Id.* at 2:33-39. The '722 patent also discloses, “The LED lamp shown in FIG, 1 also includes a fan (9) incorporated in the gear column (1), which fan generates an air flow during operation of the lamp. This air flow leaves the gear column (1) via holes (6) provided in the gear column, and re-enters the gear column via the holes (7) provided in the gear column.... By virtue thereof, an improved heat dissipation from the substrate and the LEDs is obtained.” *Id.* at 4:7-

16. Thus, the ‘722 patent discloses the subject matter claims 9 and 14-16 for anticipation by the ‘722 patent (Ground 3).

98. In addition, if the PTAB finds that the ‘722 patent does not expressly disclose heat dissipation protrusions as claimed in claim 1, then claims 9 and 14-16 are obvious under the combination of the ‘722 patent and the ‘211 patent (Ground 4) because, as explained above, it would have been obvious to add the cooling fins of the ‘211 patent or similar protrusion structures to the outer surface of the gear column 1 of the lamp of the ‘722 patent. *See, e.g.*, Ex. 1002 at 3:56-62, 3:66-4:16; Ex. 1003 at 4:6-9, 6:47-52, 5:6-31.

I. Claims 10 and 11 are obvious in view of the ‘722, ‘819 and ‘539 patents (Ground 7) and obvious in view of the ‘722, ‘819, ‘539 and ‘211 patents (Ground 8)

99. Claim 10 depends from 3 and recites, “said elongate thermally conductive member comprises an extrusion.” Claim depends from claim 10 and recites, “said extrusion is an aluminum extrusion.”

100. The ‘722 patent does not expressly disclose that the combination of the substrate 3, gear column 1, and lamp cap 2 (collectively, an elongate thermally conductive member) comprises an extrusion (claim 10) and that such extrusion is an aluminum extrusion (claim 11). However, the ‘722 patent does disclose, “The outer surface of the gear column (1) of the LED lamp is made of a metal or a metal alloy”. Ex. 1002 at 3:66-67. Aluminum is a metal and its use is commonplace in

the art in aluminum alloys (which are themselves conventionally often referred to simply as aluminum). In addition, the '819 patent describes an "LED array surface-mounted on a circuit board and applied to a cooling member, such that any generated heat is optimally eliminated," wherein "said cooling member 3 being composed of a cooling plate or being fabricated of some other metal such as copper or *aluminum*, and thus exhibiting a high thermal conductivity." Ex. 1005 at Abstract, 4:5-8 (emphasis added).

101. Moreover, the '539 patent discloses "heat transfer tubes with improved heat transfer performances, assemblies of such tubes and a method for manufacturing such tubes and tube assemblies." Ex. 1006 at 1:12-14. "[T]he tube 1 includes a tubular body 3 having an opposed pair of planar members 2a and 2b each projecting outwardly from its peripheral wall and radially with respect to its longitudinal axis and extending longitudinally along the axis and an internal fin element 4." *Id.* at 4:8-13. "[A] multiplicity of external flutes 6 running in parallel with the longitudinal axis of the tube [] provide an extended external effective heat transfer area." *Id.* at 7:8-11. According to the '539 patent, "tubular body 3 is most generally formed by *extrusion of aluminum alloy* together with a pair of planar members 2a and 2b as a single integral unit" and that "when external fins 6 are substantially triangular . . . the desired product can be easily obtained by the extrusion technique" *Id.* at 7:59-64 (emphasis added).

102. In view of the disclosures of the '819 patent and the '539 patent, a POSA would have been motivated as of the effective filing date of the '303 patent to produce the gear column 1 of the '722 patent (including, optionally, with heat fins as disclosed in the '211 patent as explained above for claims 1 and 2) using aluminum as a thermally conductive metal/alloy as taught by the '819 patent and which can be easily extruded with external heat fins according to the '539 patent for the purpose of achieving ease of fabrication of a thermally conductive tube with integrally formed heat fins as taught by the '539 patent, as explained above. There would have been a reasonable expectation of success because aluminum is easily extruded as taught by the '539 patent with integral heat fins, and the modified aluminum gear column would provide good heat conduction as taught by the '819 patent, consistent with the design goals of the lamp of the '722 patent. Accordingly, claims 10 and 11 are obvious in view of the teachings of the '722 patent, the '819 patent and the '539 patent.

103. In addition, if the PTAB finds that the '722 patent does not expressly disclose heat dissipation protrusions as claimed in claims 1 and 2, then claims 10 and 11 are obvious under the combination of the '722, '819, '539 and '211 patents (Ground 8) because, as explained above, it would have been obvious to add the cooling fins of the '211 patent or similar protrusion structures to the outer surface of the gear column 1 of the lamp of the 722 patent. *See, e.g.*, Ex. 1002 at 3:56-62,

3:66-4:16; Ex. 1003 at 4:6-9, 6:47-52, 5:6-31. Moreover, the ‘539 patent discloses that an aluminum extrusion can be easily made with external flutes (fins). Ex. 1006 at 4:9-13, 7:4-18, FIGS. 3, 7.

J. Claims 12 and 13 are obvious in view of the ‘722, ‘819 and ‘539 patents (Ground 9) and obvious in view of the ‘722, ‘819, ‘539 and ‘211 patents (Ground 10)

104. Claim 12 depends from claim 10 and recites, “said elongate thermally conductive member is a tubular member.” The ‘722 patent discloses this subject matter at least by virtue of gear column 1, lamp cap 2 and substrate 3 shown in FIGS. 1 and 2 thereof, which together form a tubular member. The ‘722 patent discloses, *e.g.*, “FIG. 1 shows a first embodiment of the invented light emitting [d]iode lamp (LED lamp). This lamp comprises a tubular, hollow gear column (1), which is connected with one end to a lamp cap (2).” Ex. 1002 at 3:38-42. Insofar as the ‘722 patent discloses the polyhedron substrate 3 as a “substrate” (indicative of thin, planar structures in the field of electrical technology), a POSA would have understood the polyhedron substrate 3 to be hollow and would have considered it to be a tubular extension of the gear column 1. A POSA would reasonably also consider the lamp cap 2 to be a base support for the gear column 1 and substrate 3 and thereby a part of the overall tubular member comprised of gear column 1, substrate 3, and lamp cap 2, or alternatively, the lamp cap 2 need not be considered part of the claimed tubular member.

105. Claim 13 depends from claim 12 and recites, “said tubular member has a polygon cross-section.” This limitation is met by the ‘722 patent for the same reasons as discussed above for claim 7. Thus, the combination of the ‘722, ‘819 and ‘539 patents render claims 12 and 13 obvious (Ground 9).

106. In addition, if the PTAB finds that the ‘722 patent does not expressly disclose heat dissipation protrusions as claimed in claims 1 and 2, then claims 12 and 13 are obvious under the combination of the ‘722, ‘819, ‘539 and ‘211 patents (Ground 10) because, as explained above, it would have been obvious to add the cooling fins of the ‘211 patent or similar protrusion structures to the outer surface of the gear column 1 of the lamp of the 722 patent. *See, e.g.*, Ex. 1002 at 3:56-62, 3:66-4:16; Ex. 1003 at 4:6-9, 6:47-52, 5:6-31.

K. Claims 12 and 13 are obvious in view of the ‘722, ‘819, ‘539 and ‘678 patents (Ground 11) and obvious in view of the ‘722, ‘819, ‘539, ‘678 patents and ‘211 patents (Ground 12)

107. If the PTAB finds that the combination of the gear column 1 and substrate 3 of the ‘722 patent, with or without the lamp cap 2, are not collectively considered the claimed tubular member, then claims 12 and 13 would nevertheless be obvious in view of the ‘772 patent, the ‘819 patent, the ‘539 patent and the ‘678 patent (Ground 11). In this regard, a POSA would have been motivated as of the effective filing date of the ‘303 patent to replace the hollow gear column 1 and polygon substrate 3 of the ‘722 patent with a simple vertical metal tube having the

uniform polygon cross-sectional shape of the metal cylinder 35 top plate shown in FIG. 3 of the '678 patent, with the LEDs 4 of the '722 patent being mounted on the side polygon surfaces and top plate of such vertical metal tube, while retaining the fan 9 and air holes 6, 7 of the '722 patent inside the modified vertical, polygon metal tube to maintain the heat dissipation benefits provided by those features, as already explained for claims 6-8 in Section G above. A POSA would have been motivated to form the modified vertical metal cylinder of an aluminum extrusion in view of the teachings of the '819 patent and the '539 patent, for reasons discussed above in Section H with regard to claims 10 and 11. In such a modified lamp of the '722 patent, with gear column 1 and substrate 3 collectively replaced with an extruded aluminum, vertical metal hollow tube having the outer polygon shape and top plate of the vertical metal cylinder 35 of the '678 patent, the resulting modified vertical metal polygon-shaped tube would suffice as the claimed tubular member (and would be extruded aluminum according to the combined teachings of the '819 patent and the '539 patent). Accordingly, claim 12 is obvious in view of the teachings of the '722 patent, '819 patent, '539 patent, the '678 patent.

108. Claim 13 depends from claim 12 and recites, "said tubular member has a polygon cross-section." This feature is satisfied by the modified lamp of the '722 patent having a modified vertical, polygon-shaped metal tube of extruded aluminum and top plate on which LEDs 4 would be mounted as described above.

This is because the cross-section of the modified vertical, polygon-shaped metal tube is intentionally modified to have a polygon cross section for reasons explained above.

109. Thus, claims 12 and 13 are obvious in view of the teachings of the ‘722 patent, ‘819 patent, ‘539 patent, the ‘678 patent (Ground 11). If the PTAB finds that the protruding threads of the lamp cap 2 of the ‘722 patent are not heat dissipation protrusions as claimed in claims 1 and 2 (for the modified lamp of the ‘722 patent as described above), then claims 12 and 13 are obvious under the combination of the ‘722, ‘819, ‘539, ‘678 and ‘211 patents (Ground 12) because it would have been obvious to add the cooling fins of the ‘211 patent or similar protrusion structures to the outer surface of the modified vertical tube with polygon cross-sectional shape of the modified lamp of the ‘722 patent as described above (which retains fan 9 and air holes 6,7, as explained above). *See, e.g.*, Ex. 1002 at 3:56-62, 3:66-4:16; Ex. 1003 at 4:6-9, 6:47-52, 5:6-31.

L. Claims 17 and 18 are anticipated by the ‘722 patent (Ground 3) and obvious in view of the ‘722 patent and the ‘211 patent (Ground 4)

110. Claims 17 depends from claim 1 and recites, “each of said light emitting diodes emits white light.” Claim 18 depends from claim 1 and recites, “at least some of said light emitting diodes emit colored light.” The ‘722 patent discloses that the LEDs 4 described therein can either be red (R), yellow (Y), green

(G) or blue (B) LEDs or white LEDs, *e.g.*: “A further embodiment of the invented LED lamp is characterized in that the faces of the polyhedron are provided with an array of LEDs, which preferably comprises at least one green, at least one red and at least one blue LED or at least one green, at least one red, at least one yellow and at least one blue LED or at least one white LED.” Ex. 1002 at 2:40-45. Thus, according to the ‘722 patent, the LEDs can be R, Y, G, B LEDs, or white LEDs, or combinations thereof, including that all can be white LEDs. Thus, the ‘722 patent discloses the subject matter claims 17 and 18 (Ground 3).

111. If the PTAB finds that the ‘722 patent does not expressly disclose heat dissipation protrusions as claimed in claims 1 and 2, then claims 17 and 18 are obvious under the combination of the ‘722 and ‘211 patents (Ground 4) because, as explained above, it would have been obvious to add the cooling fins of the ‘211 patent or similar protrusion structures to the outer surface of the gear column 1 of the lamp of the 722 patent. *See, e.g.*, Ex. 1002 at 3:56-62, 3:66-4:16; Ex. 1003 at 4:6-9, 6:47-52, 5:6-31.

M. Claims 20 and 21 are anticipated by the ‘722 patent (Ground 13)

112. Independent claim 20 is identical to claim 19, except that claim 20 does not recite the claim 19 element “said elongate thermally conductive member comprises one or more heat dissipation protrusions,” and except that claim 20 recites “said fluid is moved in said elongate thermally conductive member.” The

latter limitation is the same as that of claim 14, which the ‘722 patent discloses as explained above for claim 14. Accordingly, claim 20 is anticipated by the ‘722 patent for the same reasons explained above for claims 19 and 14.

113. Similarly, independent claim 21 is identical to claim 1, except that claim 21 does not recite the claim 1 element “said elongate thermally conductive member comprises one or more heat dissipation protrusions,” and except that claim 21 recites “said fluid is moved in said elongate thermally conductive member.” The latter limitation is the same as that of claim 14, which the ‘722 patent discloses as explained above for claim 14. Accordingly, claim 21 is anticipated by the ‘722 patent for the same reasons explained above for claims 1 and 14.

114. Accordingly, the explanations already presented above for claims 1, 19 and 14 are not presented again here. However, a claim chart showing where all of the limitations of claims 20 and 21 are found in the ‘722 patent is presented below, thereby rendering claims 20 and 21 anticipated.

CLAIMS 20 and 21 - Anticipation

Claim Element	Prior Art Teaching
<u>Claims 20 and 21</u> A light source comprising:	Ex. 1002 (‘722 patent) at 1:40-41. “These and other objects of the invention are achieved by a LED lamp...”
<u>Claims 20 and 21</u> an elongate thermally conductive member having an outer surface;	Ex. 1002 (‘722 patent) at 3:39-44. “This lamp comprises a tubular, hollow gear column (1), which is connected with one end to a lamp cap (2). The other end of the gear column (1) is connected to a substrate (3), which is provided with a number of

Claim Element	Prior Art Teaching
	<p>LEDs (4).”</p> <p>Ex. 1002 (‘722 patent) 2:20-22. “A further interesting embodiment of the LED lamp is characterized in that the heat-dissipating means comprise a metal connection between the substrate and the lamp cap.”</p> <p>Ex. 1002 (‘722 patent) at 3:56-4:6. “The outer surface to the substrate (3) is made of metal or a metal alloy, thereby enabling a good heat conduction from the LEDs (4) to the column (1)... The outer surface of the gear column (1) of the LED lamp is made of a metal or metal alloy. This enables a good heat conduction from the substrate (3) to the (metal) lamp cap (2) to be attained.”</p>
<p><u>Claim 20</u> at least one light emitting diode carried on said elongate member outer surface;</p> <p><u>Claim 21</u> a plurality of light emitting diodes carried on said elongate member outer surface</p>	<p>Ex. 1002 (‘722 patent) at 3:40-44. “This lamp comprises a tubular, hollow gear column (1), which is connected with one end to a lamp cap (2). The other end of the gear column (1) is connected to a substrate (3), which is provided with a number of LEDs (4).” See FIG. 1 and FIG. 2</p> <p>Ex. 1002 (‘722 patent) at 3:56-67. “The outer surface to the substrate (3) is made of metal or a metal alloy, thereby enabling a good heat conduction from the LEDs (4), to the column (1) The outer surface of the gear column (1) of the LED lamp is made of a metal or metal alloy.”</p>
<p><u>Claim 20</u> one or more electrical conductors carried by said elongate thermally conductive member and connected to said at least one light emitting diode to supply electrical power thereto;</p>	<p>Ex. 1002 (‘722 patent) 4:61-63. “The LED (4) is also provided with two electrical connections (14). Via these connections, the LED is soldered onto the substrate 3.”</p> <p>Ex. 1002 (‘722 patent) at 3:44-46. “The space within the hollow gear column (1) accommodates the electronic gear necessary for controlling the LEDs (4).”</p>

Claim Element	Prior Art Teaching
<p><u>Claim 21</u> electrical conductors carried by said elongate thermally conductive member and connected to said plurality of light emitting diodes to supply electrical power thereto; and</p>	<p>Ex. 1002 (“722 patent) at 1:54-58. “A particular aspect of the invention resides in that the heat-dissipating means remove the heat, generated during operation of the lamp, from the substrate via the gear column to the lamp cap and the mains supply connected thereto.”</p>
<p><u>Claim 20</u> said elongate thermally conductive member being configured to conduct heat away from said at least one light emitting diode to fluid contained by said elongate thermally conductive member; and</p> <p><u>Claim 21</u> said elongate thermally conductive member being configured to conduct heat away from said light emitting diodes to fluid contained by said elongate thermally conductive member; and</p>	<p>Ex. 1002 (“722 patent) at 3:40-44. “This lamp comprises a tubular, hollow gear column (1), which is connected with one end to a lamp cap (2). The other end of the gear column (1) is connected to a substrate (3), which is provided with a number of LEDs (4).”</p> <p>Ex. 1002 (“722 patent) at 3:56-4:2. “The outer surface of the substrate (3) is made of a metal or a metal alloy, thereby enabling a good heat conduction from the LEDs (4) to the column (1). . . . The outer surface of the gear column (1) of the LED lamp is made of a metal or a metal alloy. This enables a good heat conduction from the substrate (3) to the (metal) lamp cap (2) to be attained.”</p> <p>Ex. 1002 (“722 patent) at 2:33-39. “Yet another embodiment of the LED lamp is characterized in that means are incorporated in the column, which are used to generate an air flow in the lamp. Such means, preferably in the form of a fan, can be used, during operation of the lamp, to generate forced air cooling. In combination with the heat dissipating means, this measure enables good heat dissipation from the gear column and the substrate.”</p> <p>Ex. 1002 (“722 patent) at 4:7-16. “The LED lamp shown in FIG, 1 also includes a fan (9) incorporated in the gear column (1, which fan generates an air flow during operation of the lamp.</p>

Claim Element	Prior Art Teaching
	This air flow leaves the gear column (1) via holes (6) provided in the gear column, and re-enters the gear column via the holes (7) provided in the gear column.... By virtue thereof, an improved heat dissipation from the substrate and the LEDs is obtained.”
said fluid is moved in said elongate thermally conductive member.	<p>Ex. 1002 (‘722 patent) at 2:33-39. “Yet another embodiment of the LED lamp is characterized in that means are incorporated in the column, which are used to generate an air flow in the lamp. Such means, preferably in the form of a fan, can be used, during operation of the lamp, to generate forced air cooling. In combination with the heat dissipating means, this measure enables good heat dissipation from the gear column and the substrate.”</p> <p>Ex. 1002 (‘722 patent) at 4:7-16. “The LED lamp shown in FIG, 1 also includes a fan (9) incorporated in the gear column (1, which fan generates an air flow during operation of the lamp. This air flow leaves the gear column (1) via holes (6) provided in the gear column, and re-enters the gear column via the holes (7) provided in the gear column.... By virtue thereof, an improved heat dissipation from the substrate and the LEDs is obtained.”</p>

N. Claim 22 is anticipated by the ‘722 patent (Ground 14)

115. Independent claim 22 is identical to claim 1, except that claim 22 does not recite the claim 1 element “said elongate thermally conductive member comprises one or more heat dissipation protrusions,” and except that claim 22 recites “a coating carried on said elongate thermally conductive member.”

Accordingly, explanations for all limitations other than the last limitation of claim

22 have already been presented above for claim 1, and those explanations are not presented again here.

116. With regard to the claim element “a coating carried on said elongate thermally conductive member,” the ‘303 patent does not define a “coating” but does indicate that such coating is satisfied by an adhesive. For example, the ‘303 patent states, “Flexible printed circuit 113, in the illustrative embodiment is coated with a nonelectrically conductive epoxy that may be infused with optically reflective materials. Flexible printed circuit 113 is adhered to the tube 101 with a heat conducting epoxy to aid in the transmission of the heat from LEDs 109 to tube 101.” Ex. 1001 at 3:37-44. Likewise, the ‘722 patent discloses using adhesive in adhering a metal core printed circuit board on the metal substrate 3, *e.g.*: “If LEDs with a high luminous flux (5 lm or more) are used, then a so-called metal-core PCB is customarily used. Such PCBs have a relatively high heat conduction. By providing these PCBs on the (preferably metal) substrate by means of a heat-conducting adhesive, a very good heat dissipation from the LED arrays to the gear column is obtained.” Ex. 1002 at 2:53-59. Accordingly, the ‘722 patent discloses using adhesive coatings in a manner consistent with that described in of the ‘303 patent and claimed in claim 22, and the ‘722 patent therefore discloses this limitation of claim 22. A claim chart showing where all of the limitations of claim 22 are found in the ‘722 patent is presented below, immediately following the next

section.

O. Claim 22 is obvious in view of the ‘722 patent and the ‘347 patent (Ground 15)

117. Claim 22 is obvious in view of the ‘722 patent in combination with the ‘347 patent, in an alternative treatment of the claimed coating recited in the final limitation of claim 22. The ‘347 patent describes variety LED arrays, such as those illustrated in FIGS. 3C, 5C and 7C. The ‘347 patent discloses that “[t]he lamp 20 includes a pair of linear arrays of light emitting diodes (LEDs) 22 preferably mounted on a pair of PC boards 24. The PC boards are connected together to form a lamp frame 26 that defines a U-shaped front face 27 on which the pair of LED arrays are mounted.” Ex. 1007 at 3:64-4:1. “The front surface 27 may be formed from, or *coated with, a reflective material*. This configuration *results in lamp 20 evenly illuminating an area* of the adjacent sign face that is significantly wider than the width of the lamp itself.” *Id.* at 4:17-21 (emphasis added). Regarding FIG. 5C embodiment, the ‘347 patent also states, “The front/back faces 27/53 may be formed from, or coated with, a reflective material.” *Id.* at 5:33-35. Regarding FIG. 7C embodiment, the ‘347 patent also states, “Front/rear faces 58/62 may be formed from, or coated with, a reflective material. This embodiment *brightly and evenly illuminates* two opposing faces” *Id.* at 5:63-66 (emphasis added). A POSA would have been motivated as of the effective filing date of the ‘303 patent to provide a reflective coating as disclosed in the ‘347

patent on the surface of the substrate 3 on which the LEDs 4 of the '722 patent are mounted for the purpose of facilitating bright and even illumination as taught by the '347 patent. There would have been a reasonable expectation of success since providing such a coating of reflective material would have been conventional in the art (so conventional, in fact, that the '347 patent does not disclose any particular method), and such coating of optically reflective material reasonably would have been understood by a POSA to improve uniformity of illumination as disclosed in the '347 patent. A variety of coating approaches would have been applicable, such as brushing a liquid suspension with reflective material, spraying such a liquid suspension, solution plating or metal deposition (such as electroplating or electroless plating), and the like.

118. I observed that the '347 was applied by the PTO for the same teaching of a coating of optically reflective material in rejecting substantially similar claims in U.S. Patent Application No. 10/430,696 ("the '696 application," abandoned), a sibling of the '303 patent. See Ex. 1019, Pros. Hist. of the '696 application at 32-33, 38. See also *id.* at 55 (in which the Applicant did not dispute the teachings of the '347 patent regarding coatings of optically reflective material and instead amended claims to overcome the obviousness type double patenting rejection in view of claims of the '536 patent and the '347 patent at issue).

119. A claim chart showing where all of the limitations of claim 22 are

found in the '722 patent alone or in combination with the '347 patent is shown below.

CLAIM 22 – Anticipation and Obviousness

Claim Element	Prior Art Teaching
Claim 22. A light source comprising:	Ex. 1002 ('722 patent) at 1:40-41. "These and other objects of the invention are achieved by a LED lamp..."
an elongate thermally conductive member having an outer surface;	<p>Ex. 1002 ('722 patent) at 3:39-44. "This lamp comprises a tubular, hollow gear column (1), which is connected with one end to a lamp cap (2). The other end of the gear column (1) is connected to a substrate (3), which is provided with a number of LEDs (4)."</p> <p>Ex. 1002 ('722 patent) at 2:20-22. "A further interesting embodiment of the LED lamp is characterized in that the heat-dissipating means comprise a metal connection between the substrate and the lamp cap."</p> <p>Ex. 1002 ('722 patent) at 3:56-4:2. "The outer surface to the substrate (3) is made of metal or a metal alloy, thereby enabling a good heat conduction from the LEDs (4) to the column (1)... The outer surface of the gear column (1) of the LED lamp is made of a metal or metal alloy. This enables a good heat conduction from the substrate (3) to the (metal) lamp cap (2) to be attained."</p>
a plurality of light emitting diodes carried on said elongate member outer surface	Ex. 1002 ('722 patent) at 3:40-44. "This lamp comprises a tubular, hollow gear column (1), which is connected with one end to a lamp cap (2). The other end of the gear column (1) is connected to a substrate (3), which is provided with a number of LEDs (4)." See FIG. 1 and FIG. 2

Claim Element	Prior Art Teaching
	<p>Ex. 1002 ('722 patent) at 3:56-67. "The outer surface to the substrate (3) is made of metal or a metal alloy, thereby enabling a good heat conduction from the LEDs (4), to the column (1) The outer surface of the gear column (1) of the LED lamp is made of a metal or metal alloy."</p>
<p>at least some of said light emitting diodes being disposed in a first plane and others of said light emitting diodes being disposed in a second plane not coextensive with said first plane;</p>	<p>Ex. 1002 ('722 patent) at 3:53-61. "In the example described herein, the substrate (3) has the shape of a pyramid with four flat faces.... Each of the faces of the pyramid is provided with a number (five or six) LEDs (4), which are secured to the faces by means of a heat-conducting adhesive."</p> <p>Ex. 1002 ('722 patent) 4:23-31. "In the example described with respect to FIG. 2, the substrate (3) is cube-shaped with six flat faces.... Each one of the faces ... is provided with a number (eight or nine) LEDs (4). ..."</p>
<p>electrical conductors carried by said elongate thermally conductive member and connected to said plurality of light emitting diodes to supply electrical power thereto; and</p>	<p>Ex. 1002 ('722 patent) 4:61-63. "The LED (4) is also provided with two electrical connections (14). Via these connections, the LED is soldered onto the substrate 3."</p> <p>Ex. 1002 ('722 patent) at 3:44-46. "The space within the hollow gear column (1) accommodates the electronic gear necessary for controlling the LEDs (4)."</p> <p>Ex. 1002 ('722 patent) at 1:54-58. "A particular aspect of the invention resides in that the heat-dissipating means remove the heat, generated during operation of the lamp, from the substrate via the gear column to the lamp cap and the mains supply connected thereto."</p>
<p>said elongate thermally conductive member being configured to conduct heat away from said light emitting diodes to fluid</p>	<p>Ex. 1002 ('722 patent) at 3:40-44. "This lamp comprises a tubular, hollow gear column (1), which is connected with one end to a lamp cap (2). The other end of the gear column (1) is connected to a substrate (3), which is provided with a number of</p>

Claim Element	Prior Art Teaching
<p>contained by said elongate thermally conductive member; and</p>	<p>LEDs (4).”</p> <p>Ex. 1002 (‘722 patent) at 3:56-4:2. “The outer surface of the substrate (3) is made of a metal or a metal alloy, thereby enabling a good heat conduction from the LEDs (4) to the column (1). . . . The outer surface of the gear column (1) of the LED lamp is made of a metal or a metal alloy. This enables a good heat conduction from the substrate (3) to the (metal) lamp cap (2) to be attained.”</p> <p>Ex. 1002 (‘722 patent) at 2:33-39. “Yet another embodiment of the LED lamp is characterized in that means are incorporated in the column, which are used to generate an air flow in the lamp. Such means, preferably in the form of a fan, can be used, during operation of the lamp, to generate forced air cooling. In combination with the heat dissipating means, this measure enables good heat dissipation from the gear column and the substrate.”</p> <p>Ex. 1002 (‘722 patent) at 4:7-16. “The LED lamp shown in FIG, 1 also includes a fan (9) incorporated in the gear column (1, which fan generates an air flow during operation of the lamp. This air flow leaves the gear column (1) via holes (6) provided in the gear column, and re-enters the gear column via the holes (7) provided in the gear column. . . . By virtue thereof, an improved heat dissipation from the substrate and the LEDs is obtained.”</p>
<p>a coating carried on said elongate thermally conductive member.</p>	<p><u>Anticipation</u></p> <p>Ex. 1002 (‘722 patent) at 2:53-59 (emphasis added). “If LEDs with a high luminous flux (5 lm or more) are used, then a so-called metal-core PCB is customarily used. Such PCBs have a relatively high heat conduction. By providing these PCBs on the (preferably metal) substrate by means of a heat-</p>

Claim Element	Prior Art Teaching
	<p>conducting <u>adhesive</u>, a very good heat dissipation from the LED arrays to the gear column is obtained.”</p> <p><u>Obviousness</u> Ex. 1007 (‘347 patent) at 3:66-4:1. “The PC boards are connected together to form a lamp frame 26 that defines a U-shaped front face 27 on which the pair of LED arrays are mounted.”</p> <p>Ex. 1007 (‘347 patent) at 4:17-21. “The front surface 27 may be formed from, or coated with, a reflective material. This configuration results in lamp 20 evenly illuminating an area of the adjacent sign face that is significantly wider than the width of the lamp itself.” <i>See also</i> 5:33-35, 5:63-67.</p>

P. Claim 23 is obvious in view of the ‘722 patent and the ‘347 patent (Ground 16)

120. Claim 23 depends from claim 22 and recites, “said coating is infused with optically reflective material.” The combination of the ‘722 patent and the ‘347 patent disclose this subject matter as explained above for claim 22. The ‘347 patent discloses LED illumination sources comprising LED arrays with a surface of a frame on which the LEDs are mounted that may be coated with a reflective material so as facilitate even illumination as discussed above with regard to the obviousness treatment of claim 22 in view of the combination of the ‘722 patent and ‘347 patent. Ex. 1007 at 3:64-4:1, 4:17-21, 5:33-35, 5:63-67, Abstract, FIGS. 3C, 5C, and 7C. Accordingly, claim 23 is obvious in view of the combination of the ‘722 patent and the ‘347 patent as explained above for Claim 22.

121. I hereby declare that all statements made herein of my own knowledge are true and that all statements made on information and belief are believed to be true; and further that these statements were made with the knowledge that willful false statements and the like so made are punishable by fine or imprisonment, or both, under Section 1001 of Title 18 of the United States Code.

Executed this 10th day of April, 2017 in San Francisco, California.

Respectfully submitted



Jianzhong Jiao

APPENDIX A

LIST OF EXHIBITS

Ex. 1001	U.S. Patent No. 6,831,303 (“the ‘303 patent”)
Ex. 1002	U.S. Patent No. 6, 220,722 (“the ‘722 patent” or “Begemann”)
Ex. 1003	U.S. Patent No. 6,682,211 (“the ‘211 patent” or “English”)
Ex. 1004	U.S. Patent No. 6,425,678 (“the ‘678 patent” or “Verdes”)
Ex. 1005	U.S. Patent No. 6,848,819 (“the ‘819 patent” or “Arndt”)
Ex. 1006	U.S. Patent No. 4,296,539 (“the ‘539 patent” or “Asami”)
Ex. 1007	U.S. Patent No. 5,949,347 (“the ‘347 patent” or “Wu”)
Ex. 1008	Declaration of Jianzhong Jiao (“the Jiao Decl.”)
Ex. 1009	Amended Complaint dated February 2, 2017 in <i>OptoLum v. Cree, Inc.</i> , 2:16-cv-3828 (D. Ariz.)
Ex. 1010	U.S. Patent No. 6,573,536 (“the ‘536 patent”)
Ex. 1011	Prosecution History of U.S. Patent Application No. 10/430,732
Ex. 1012	Prosecution History of U.S. Patent Application No. 10/156,810
Ex. 1013	U.S. Patent No. 6,462,669 (“the ‘669 patent”)
Ex. 1014	U.S. Patent Application Publication No. 20020005826 (“the ‘826 publication”)
Ex. 1015	U.S. Patent Application Publication No. 20010049893 (“the ‘893 publication”)
Ex. 1016	U.S. Patent Application Publication No. 20020191396 (“the ‘396 publication”)
Ex. 1017	Prosecution History of U.S. Patent Application No. 10/631,027
Ex. 1018	U.S. Patent No. 6,799,864 (“the ‘864 patent”)
Ex. 1019	Prosecution History of U.S. Patent Application No. 10/430,696 (“the ‘696 application”)

APPENDIX B

CV of JIANZHONG JIAO, PH.D.

OUTLINE OF EXPERTISE

- Internationally recognized expert in the field of lighting, LEDs and light sources, optical and illumination engineering.
- Highly experienced with government relations, regulations, and specifications.
- Leader and major contributor for the LED and lighting industry standards development.
- Many years of leadership experience in major corporations for managing engineering, research, technology development, product design, testing, standards, compliance, technology and business strategies, intellectual property management, academic and governmental interfaces.
- High technical skills in optical, electrical, mechanical engineering and computer applications, specializing in lighting and LED product design and development.
- Excellent communication and teaching skills.
- Experienced expert witness, technical and business consultant for lighting and LED related civil and intellectual property litigations, technology strategies, and financial investments.

EMPLOYMENT EXPERIENCE – INDUSTRIAL

09/2015 – Present

San Francisco, CA

Consultant – Consultation for industry, government agencies, academia, and professional associations in the areas of LEDs, lasers, and lighting. Examples of recent projects:

- U.S. DOE SSL R&D project reviews.
- Laser headlamp and ADB technology development for a government sponsored project.
- Technology scouting, design review, and standard development for a major LED manufacturer and a major automotive lighting (tier-one) supplier.
- Testing and evaluations standards compliance for photometry instruments manufacturers.
- M&A strategies for automotive lighting (tier-one) suppliers.
- Expert witness for IP disputes and litigations.

06/2007 – 09/2015

Sunnyvale, CA

Director – Regulations and Emerging Technologies, OSRAM Opto Semiconductors Inc. (www.osram-os.com, OSRAM Opto is one of the world-wide largest LED companies, a subsidiary of OSRAM GmbH).

Responsibilities and Major Accomplishment:

- Function as company's NAFAT liaison for technology scouting and monitoring in industry, academics, and startups.

Jianzhong Jiao, Ph.D.

750 Van Ness Avenue, Unit 805, San Francisco, CA 94102, 415-606-3322, j_jiao@hotmail.com

- Interface with academic and industrial consortium programs to present the company's positions and collaborate product and technology development strategies with LED, laser, sensor, and lighting industry.
- Manage LED and lighting regulations and standards activities.
- As the company's representative, interface with US governmental agencies such as U.S. DOE, DOT, EPA, and DOC, as well as state level authorities such as CEC, etc.
- Interface and participate in the U.S. professional, standard and trade organizations such as ANSI, SAE, IESNA, NEMA, UL, IEEE, JEDEC, SEMI, ASABE, CIE-USA, etc. to establish and revise industry standards relating to LEDs and lasers.
- Establish strategies for the emerging technologies that relate to LED, lasers and their applications.
- Established company-wide system to integrate standard and regulation requirements into product development and quality management; transferred the engineering mentality and awareness from a high-tech semiconductors base to lighting commodities; strategically place the company's position in standardization bodies.
- Manage the LED technology strategies and implementations in the fields of automotive, general illumination, horticulture, display, medical, defense, and others in the NAFTA market.

08/1993 – 06/2007

Farmington Hills, MI

General Manager (Previously Manager up to 10/1998) – Engineering Technology, North American Lighting, Inc. (www.nal.com, a primary and the largest automotive lighting supplier in North America and an affiliation of Koito www.koito.co.jp, the world-wide largest automotive lighting company).

Responsibilities and Major Accomplishment:

- Provided strategic planning for new technology implementation and new business development
- Established from ground zero and manage world-class engineering team consisted of four departments: Optical Design, Electronic Technologies, Engineering Analysis, and Regulation and Standards
- Assisted the company to grow and expand the US customers base and revenue from \$100 million to a half billion, and made the company as the largest US automotive lighting supplier.
- Investigated, identified and negotiated technology transfer and technology exchange with the foreign shareholder companies.
- Managed intellectual property protection including patent applications

09/1989 – 08/1993

Troy, MI & Anderson, IN

Sr. Development Engineer & Project Manager – Advanced Development in Lighting, General Motors Corporation, IFG Division.

- Participated in and managed R&D projects in technology development to implement state-of-the-art technologies in automotive lighting applications.
- Led technology development projects including holograms, optical waveguides and light guides, fiber optics, non-imaging optics, computer-aided optical design, thermal analysis, LED, HID, neon and other new light source applications in the automotive lighting systems.

EMPLOYMENT EXPERIENCE – ACADEMIC

01/2010 – Present

Industry Advisory Board Member – Smart Lighting Engineering Research Center (ERC)

The ERC was created in 2008 at Rensselaer Polytechnic Institute (RPI). Funded by the National Science Foundation and the State of New York, RPI works with core partners Boston University and the University of New Mexico to investigate and develop light-emitting diode (LED) technologies that will one day change the way we illuminate our world. The ERC is a superb example of how academia, federal and state governments, and industry can work together to advance the state of science and engineering while creating new opportunities for students, faculty, and businesses.

03/2003 – Present

Instructor – Professional Seminars, Society of Automotive Engineers Continuing Education Programs.

- Teach three college credited short courses both publicly and customer in-house:
- SAE Seminar C0202, “*Automotive Lighting I – Design & Technology*”: Lighting fundamentals, design principles and new technologies, 2-days course.
 - SAE Seminar C0618, “*Automotive Lighting II – Testing & Requirement*”: Automotive lighting definitions, terminologies, testing, and requirements, 1-day course.
 - SAE Seminar C0727, “*Automotive Lighting III – LED Application*”: LED basics, LED measurements and standardization, LED automotive exterior and interior lighting design strategies and concepts, 1-day course.

01/2009 – Present

Instructor – Short Course, SPIE – Society of International Optical Engineers.

Teach college credited short course SC958 “*LED & Solid-State Lighting Standardization and Metrology*”.

05/2011 – Present

Instructor – Workshop, Strategies in Light

Teach workshop “*LED & LED Lighting Standards and Methods of Measurements*”.

05/2010 – Present

Instructor – Short Course and Workshop, Light Fair International

Teach college credited short course “*LED & Solid-State Lighting Standardization*” and “*Methods of Measurements for LEDs*”.

09/1992 – 06/1997

Southfield, MI

Faculty (Adjunct) – Department of Physics and Department of Electrical Engineering, Lawrence Technological University.

Taught undergraduate courses: non-calculus based and calculus based college physics including instructing laboratory experiments; taught undergraduate course: optical engineering.

09/1990 – 06/1992

Anderson, IN

Faculty (Adjunct) – Department of Physics, Purdue University Anderson Campus.

Taught undergraduate courses: Physical Sciences including instructing laboratory experiments.

01/1985 – 09/1989

Evanston, IL & Troy, NY

Teaching Assistant/Research Assistant – Department of Electrical Engineering and Computer Science, Northwestern University, Evanston, IL; Department of Physics, Rensselaer Polytechnic Institute.

Assisted undergraduate courses in physics and electrical engineering, instructed laboratory courses, conducted problem solving sessions, graded homework and exams.

07/1983 – 12/1984

Beijing, China

Assistant Professor – Department of Applied Physics, Beijing Institute of Posts and Telecommunications.

Taught undergraduate courses: physical optics, modern optics including laboratory experiments.

EXPERT WITNESS EXPERIENCE

Case No. 2:13-CV-06383-JD, Dorman Products, Inc. vs. Paccar Inc.

Case No. CV12-CV-229, Arthur Wolf vs. Indian Motor Company, Polaris Industries Inc., and Paul Burger, D/B/A Burger Enterprises.

Case No. CV08-07078 DDP (VBKx), Grand General Accessories Manufacturing, Inc., vs. United Pacific Industries.

Case No. 1:09-CV-07151-RJS, Carlos Collado, Richard Hock, Bill Urban, Enrique Cantu, Paul Bigbie, William Askew, Jacek Pawlowicz, and James Freeman, on behalf of themselves and all others similarly situated vs. Toyota Motor Sales, U.S.A., Inc.

Case No. 2:10-CV-03113-R-RMC, Carlos Collado, on behalf of himself and all others similarly situated vs. Toyota Motor Sales, U.S.A., Inc.

INDUSTRIAL & PROFESSIONAL SOCIETY LEADERSHIP

2004 – Present

Active Member and Leader – US professional associations, trade associations and standardization organizations that are developing LED and LED lighting standards include:

- **Chair**, ASABE Plant Growth LED Lighting Committee
- **Chair** (2008 – 2011), **Vice Chair** (2004 – 2008), SAE Lighting Standard Committee
- **Vice Chair**, ANSI TC78 WG09 SSL Light Source Committee
- Member, ANSI TC82 WG04 SSL Driver Committee
- **Treasurer**, IESNA Testing Procedures Committee
- Member, IESNA Roadway Lighting Committee
- **Vice Chair**, IESNA Light Source Committee
- **Chair**, IESNA Computer Committee Ray File Subcommittee
- Member, CIE TC2-76, AC LED Characterization Working Group
- Member, UL8750 LED Source Safety Standard Technical Panel
- Member, IEEE PAR 1789 LED Flicker Health Hazards Committee
- **Chair** (2007 – 2009), NEMA Lighting Division, SSL Section Technical Committee
- Member, SEMI North America, High Brightness LED Standard Committee
- Member, JEDEC C-15 LED Thermal Measurement Committee
- **Chair** (2008 – 2009), Next Generation Lighting Industry Alliance (NGLIA)

1996 – Present

Organizer & Chairman – SAE World Congress, Lighting Technology Conference, Detroit, MI

Organize the largest international automotive lighting technology annual events, review technical papers and presentations, invite speakers on selected topics, establish conference programs, chair the conferences, and edit proceedings.

2008 – Present

Conference Organizer and Session Chairman – SPIE Optics + Photonics, International Conference on Solid-State Lighting, and LED-Based Illumination Systems, San Diego, CA

Participation in organizing one of the largest international conferences on LEDs and SSL, review topics, invite speakers, establish conference programs, and chair the conferences.

1996 – Present

Organizer – SAE Lighting Forum

Organized and facilitated Forum for education and information exchange of the topics of:

- LEDs: The Latest and Greatest
- Safety: Vehicular Lighting and Roadway Lighting
- IR and Night Vision Technologies
- LED Technology Update
- Glare, Human Factor's Perspectives
- Color & CRI
- Intelligent Lighting Systems

Lead, Major Contributor, or Working Group Member – Newly established LED lighting standards include:

- ANSI C78.377-2015, *Specifications for the Chromaticity of Solid-State Lighting Products*
- ANSI C78.374-2015, *LED Specification Sheet*
- IES LM-79-08, *Approved Method for the Electrical and Photometric Measurements of Solid-State Lighting Products*
- ANSI/IES LM-80-15, *Approved Method for Measuring Luminous Flux and Color Maintenance of LED Packages, Arrays, and Modules*
- IES TM-21-11, *Projecting Long Term Lumen Maintenance of LED Light Sources*
- IES LM-82-12, *Approved Method for the Characterization of LED Light Engines and LED Lamps for Electrical and Photometric Properties as a Function of Temperature*

- IES LM-84-14, *Approved Method for Measuring Lumen Maintenance of LED Lamps, Light Engines, and Luminaires*
- IES TM-28-14, *Projecting Long Term Lumen Maintenance of LED Lamps and Luminaires*
- IES LM-85-14, *Approved Method for the Electrical and Photometric Measurements of High-Power LEDs*
- IES TM-25-13, *Ray File Format for the Description of the Emission Property of Light Sources*
- IES TM-27-14, *IES Standard Format for the Electronic Transfer of Spectral Data*
- IES TM-26-15, *Projection of LED Package Failure Rate*
- IES LM-86-15, *Approved Method for Measuring Luminous Flux and Color Maintenance of Remote Phosphor Components*
- UL8750, *LED Equipment for Use in Lighting Products*
- NEMA SSL-1, *Electronic Drivers for LED Device, Arrays, or Systems*
- NEMA SSL-3, *High Power White LED Binning for General Illumination*
- NEMA SSL-4, *SSL Retrofit Lamps: Suggested Minimum Performance Requirements*
- SEMI 5265A, *Specifications for Sapphire Wafers Intended for Use for Manufacturing High Brightness Light-Emitting Diode Devices*
- JESD51-51, *Implementation of the Electrical Test Method for the Measurement of Real Thermal Resistance and Impedance of Light-Emitting Diodes with Exposed Cooling*
- SAE J1889, *LED Signal and Marking Lighting Devices*
- SAE J2650, *Performance Requirements for Light Emitting Diode Road Illumination Devices*
- SAE J2938, *LED Light Sources Tests and Requirements Standard Part 2: LED Lumen and Color Maintenance Measurements*
- SAE J3014, *Highly Accelerated Failure Test (HAFT) for Automotive Lamps with LED Assembly*

EDUCATION

- 1985-89 **Ph.D. in Electrical Engineering**, Northwestern University, (GPA 4.0/4.0), Evanston, IL
- 1985 Graduate Studies (Ph.D. Program) in Physics, Rensselaer Polytechnic Institute, (GPA 4.0/4.0), Troy, NY
- 1980-83 **M.S. in Applied Physics**, Beijing Institute of Posts and Telecommunications, Beijing, China
- 1976-80 **B.S. in Mechanical Engineering**, Beijing Polytechnic University, Beijing, China

PROFESSIONAL TRAINING

- 08/2015 **Change Leadership**, Cornell University eCornell online Certificate.
- 09/2009 **Photometry Short Course**, National Institute of Standard Technology, US DOC.

- 05/2007 **Leadership Beyond Management**, University of Wisconsin Business School, a comprehensive executive training program focused on emotional intelligence in a leadership role.
- 05/1995 **Executive Communication**, University of Michigan Business School, an intensive and comprehensive training program taught by dedicated well-known professors specializing in communications.
- 1990-2005 Management Training Courses & Seminars:
- Fundamentals of Accounting and Budgeting
 - How to Effectively Working with Japanese
 - Negotiation Skills
 - Business Writing for Results
 - Management Skills for New Technical Managers and Supervisors
 - Program Management; Lead-Time Reduction; Problem Solving
 - Quality Function Deployment (QFD)
 - System of Experimental Design (Taguchi Method)

U.S. PATENTS

1. "Self-Aim Vehicle Light Device", U.S. Patent No. 7,144,141
2. "Apparatus and Method for Providing a Modular Vehicle Light Device", U.S. Patent No. 7,059,754
3. "Reflector Apparatus for a Tubular Light Source" U.S. Patent No. 6,953,261
4. "Vehicle Fog Lamp", U.S. Patent No. D503,004
5. "Light Coupler Hingedly Attached to a Light Guide for Automotive Lighting", U.S. Patent No. 6,623,132.
6. "Display Device Using a Light Guide for Exterior Automotive Lighting", U.S. Patent No. 6,305,813.
7. "Automotive Headlamp Reflector and Method for Its Design", U.S. Patent No. 6,007,224.
8. "Fiber Optic Light Coupler", U.S. Patent No. 5,390,265
9. "Illuminator Device for a Display Panel", U.S. Patent No. 5,197,792

BOOKS

1. Editor: "*Automotive Lighting Technology and Human Factors in Driver Vision and Lighting*", Published by SAE SP2300, April 2011
2. Editor: "*Automotive Lighting Technology and Human Factors in Driver Vision and Lighting*", Published by SAE SP2266, April 2010
3. Editor: "*Automotive Lighting Technology*", Published by SAE SP-2223, April 2009
4. Editor: "*Automotive Lighting Technology*", Published by SAE SP-2149, April 2008
5. Editor: "*Automotive Lighting Technology and Human Factors in Driver Vision and Lighting*", Published by SAE SP-2106, April 2007
6. Editor: "*Automotive Lighting Technology and Human Factors in Driver Vision & Lighting; Rear Vision & Indirect Vision*", Published by SAE SP-1993, April 2006
7. Editor: "*Lighting Technology and Human Factors*", Published by SAE SP-1932, April 2005

8. Editor: “*Lighting*”, Published by SAE SP-1875, March 2004
9. Editor: “*Lighting Technology*”, Published by SAE SP-1787, March 2003
10. Editor: “*Advanced Lighting Technologies for Vehicles*”, Published by SAE SP-1668, March 2002
11. Editor: “*Lighting Technology Development for Automobiles*”, Published by SAE SP-1595, March 2001
12. Editor: “*Automotive Lighting Research*”, Published by SAE SP-1531, March 2000
13. Editor: “*Advances in Automotive Lighting Technologies*”, Published by SAE SP-1424, March 1999
14. Editor: “*Automotive Lighting Technology*”, Published by SAE SP-1323, March 1998
15. Editor: “*New Concepts in Automotive Lighting Technology*”, Published by SAE SP-1249, March 1987

TECHNICAL PAPERS & ARTICLES

1. “SAE Adds New Standards for LED-Based Automotive Lighting”, *LED Magazine*, February 2017.
2. “ASABE Committee Continue Work on LED Horticultural Lighting Standards”, *LED Magazine*, November 2016.
3. “Industry Progresses on Testing Standard for AC-driven LEDs”, *LED Magazine*, February 2016.
4. “ANSI Continues Advancements on SSL Chromaticity Standard”, *LED Magazine*, December 2015.
5. “IES Explores Projection Method Developments Using LM-80 Data”, *LED Magazine*, September 2015.
6. “Stakeholders Make Progress on LED Lighting Horticulture Standards”, *LED Magazine*, June 2015.
7. “Illuminating Engineering Society Updates LED Testing Standards”, *LED Magazine*, April 2015.
8. “ANSI Works to Update the SSL Chromaticity Standard”, *LED Magazine*, February 2015.
9. “IES Establishes New Standard for Spectral Data Transfer”, *LED Magazine*, December 2014.
10. “LED Automotive Lighting Applications Require Unique SAE Standards”, *LED Magazine*, September 2014.
11. “ANSI Recognizes Need for LED Drive Testing Standard”, *LED Magazine*, June 2014.
12. “IES LM-85 Homogenizes High-Power LED Measurement and Characterization”, *LED Magazine*, February 2014.
13. “IES TPC Considers LM Standard for Remote Phosphor Optics”, *LED Magazine*, December 2013.
14. “IES Moves to Establish LED Light Source Ray File Standard”, *LED Magazine*, July 2013.
15. “New Standards Will Enable Lumen Maintenance Projection for SSL”, *LED Magazine*, April 2013.

16. "ANSI Works to Standardize LED Datasheet for White LEDs", *LED Magazine*, February 2013.
17. "SEMI Committee Progresses in HB LED Process Standards", *LED Magazine*, October 2012.
18. "Standards Emerge for Thermal Characterization of LEDs", *LED Magazine*, September 2012.
19. "JEDEC Test Standards and LED Package Reliability", *LED Magazine*, April 2012.
20. "Testing LEDs for Automotive Lighting Applications", SAE World Congress, Detroit, MI, April 2012.
21. "Lumen Maintenance Testing for LED Lamps, Light Engines, and Luminaires", *LED Magazine*, February 2012.
22. "A Method for Projecting Lumen Maintenance of LED light Sources", IES Annual Conference, Austin, TX, November 2011.
23. "Understand the Difference between LED Rated Life and LED Lumen Maintenance Life", *LED Magazine*, October 2011.
24. "ANSI Evaluates Revisions to SSL Chromaticity Standard", *LED Magazine*, August 2011.
25. "LED Safety Standard UL8750 Requires Further Clarification", *LED Magazine*, April 2011.
26. "TM-21 Seeks Methods for Lumen Maintenance Prediction", *LED Magazine*, February 2011.
27. "Non-Directional Luminaires Require New Testing Procedures for LED Light Engines", *LED Magazine*, December 2010.
28. "LED Lighting Community Benefits from Ongoing Standardization Efforts", *LED Magazine*, April 2010.
29. "Standardization for Light Emitting Diodes and Solid-State Lighting", *LED Journal*, August/September 2009.
30. "High-Efficiency Reflector Optics for LED Forward Lighting", *SPIE Proceedings Vol. 6670*, September 2007.
31. "Optical Transform Limitations in Headlamp Photometric Performance", *SAE Technical Paper Series 2005-01-0861*, April 2005.
32. "Studies for Headlamp Optical Design Using LEDs", *SAE Technical Paper Series 2004-01-0434*, March 2004.
33. "Etendue Concern for Automotive Headlamp Using LEDs", *SPIE Proceedings Vol. 5187*, January 2004.
34. "Temperature Predictions Using Thermal Database and Design Sensitivity Analysis", *SAE Technical Paper Series 1999-01-0699*, March 1999.
35. "Environment Leading to Condensation in Automotive Lamps", *SAE Technical Paper Series 980316*, February 1998.
36. "Study of Tubular Volume Light Source Intensity Distribution", *SAE Technical Paper Series 980320*, February. 1998.
37. "Design Strategy for Free-Form Reflector Head Lamp Using High Intensity Discharge Light Source", *SAE Technical Paper Series 970092*, February 1997.
38. "High Performance Fog Lamps: Design Strategies and Proper Usage", *SAE Technical Paper Series 960928*, February 1996.

39. "Low Beam Head Lamp Design Using Distributive Lighting System", *SAE Technical Paper Series 960489*, February 1996.
40. "Automotive Head Lamp Beam Pattern Uniformity Evaluation", *SAE Technical Paper Series 960789*, February 1996.
41. "Quantitative Evaluation of the Uniformity for an Automotive Head Lamp Beam Pattern", *SPIE Proceedings Vol. 2622*, August 1995.
42. "Intelligent Vehicle Lighting", Convergence, Dearborn, MI, October 1994.
43. "Relief Holograms on an Optical Waveguide Using Embossing or Injection Molding", OSA Annual Meeting, Albuquerque, NM, September 1992.
44. "Fiber Optic Application in Automotive Lighting system", (GM) Engineering Technology Conference, Warren, MI, June 1991.
45. "Recent Developments on Holography in China", *SPIE Proceedings Vol. 1238*, February 1991.
46. "Holographic Technology in Automobile Lighting System", (GM) Product Engineering Technology Conference, Warren, MI, May 1990.
47. "Boundary Layer Analysis of Infrared Whispering-Gallery Waveguides", *SIAM Journal on Applied Mathematics Vol. 50, No. 2*, 1990.
48. "Transverse Magnetic Loss in a Uniformly Bent Metallic Waveguide at 10.6 μ m", *Applied Optics, Vol. 29, No. 18*, 1990.
49. "Losses of Infrared Biconcave Metallic Whispering-Gallery Waveguides", *Infrared Physics, Vol. 29 No. 213*, 1989.
50. "Losses for Vector Solutions of Infrared Whispering-Gallery Waveguides", Society of Industrial and Applied Mathematics Annual Meeting, Minneapolis, Minnesota, July 1988
51. "Wigner Distribution Function and Optical Geometrical Transformation", *Applied Optics, Vol. 23, No. 8*, 1984

INVITED SPEECHES & PRESENTATIONS

1. "LED Lighting Standards and Methods of Measurements", Strategies in Lights, Anaheim, CA, February 2017.
2. "LED Lighting Standards and Methods of Measurements", Strategies in Lights, Santa Clara, CA, February 2016.
3. "Methods of Measurements for LEDs and LED Lighting", Light Fair International, New York, NY, May 2015.
4. "LED Lighting Standards and Methods of Measurements", Strategies in Lights, Las Vegas, NV, February 2015.
5. "Methods of Measurements for LEDs and LED Lighting", Light Fair International, Las Vegas, NV, June 2014.
6. "LED Lighting Standardization in the U.S.", CIE 2014 Lighting Quality & Energy Efficiency, Kuala Lumpur, Malaysia, April 2014.
7. "LED Lighting Standards and Methods of Measurements", Strategies in Lights, Santa Clara, CA, February 2014.
8. "LED & Solid-State Lighting Standards in the U.S.", LEDs Magazine Webcast, September, 2013.

9. "LED Automotive Lighting Standards Development in SAE", First International Forum on Automotive Lighting, Kunshan, China, June 2013.
10. "LED Lighting Standards and Methods of Measurements", Strategies in Lights, Santa Clara, CA, February 2013.
11. "LED & Solid-State Lighting Standards and Metrology", SPIE Photonics West, San Francisco, CA, February 2013.
12. "LED and Solid State Lighting Standardization in U.S.", LED Korea 2013 Conference, Seoul, Korea, January 2013.
13. "The Latest in LED Lighting Test Methods and Standards", The US EPA Energy Star Partner Meeting, St. Paul, MN, October 2012.
14. "LED Standards and Measurement Methods", Light Fair International, Las Vegas, NV, May 2012.
15. "Updates for LED and SSL Standards", Strategies in Lights, Santa Clara, CA, February 2012.
16. "New LED Lighting Standards", ArchLED 2011, Chicago, IL, November 2011.
17. "LED Lighting Standards in ENERGY STAR® Programs", The U.S. EPA Energy Star Partner Meeting, Charlotte, NC, November 2011.
18. "LED Lighting Standardization Overview", SPIE Optics + Photonics, Eleventh International Conference on Solid State Lighting, San Diego, CA, August, 2011.
19. "LED Lighting Standardization", Light Fair International, Philadelphia, PA, May 2011.
20. "LED Lighting Standardization Overview", Strategies in Lights China, Hong Kong, China, May 2011.
21. "LED Lighting Standardization Overview", Strategies in Lights, Santa Clara, CA, February 2011.
22. "LED Lighting Standardization in the U.S. Overview", Strategies in Lights Japan, Yokohama, Japan, October, 2010.
23. "LED & Solid-State Lighting Standardization", Light Fair International, Las Vegas, NV, May 2010.
24. "LED Lighting Standardization Updates", ArchLED 2010, Chicago, IL, June 2010.
25. "Update on Standards for LED Lighting", Strategies in Lights, Santa Clara, CA, February 2010.
26. "Standards for LED Testing", Solid-State Lighting and Testing Forum, Taipei, Taiwan, December 2009.
27. "LED & Solid-State Lighting Standardization", SSL Design Summit, New York NY, November 2009.
28. "LED & Solid-State Lighting Standardization in NEMA", LEDs 2009 (by Intertech Pira), San Diego, CA, October 2009.
29. "LED & Solid-State Lighting Standards and Standardization", ArchLED 2009, Chicago, IL, October 2009.
30. "High power InGaN LEDs", The Electrochemical Society 215th Meeting, San Francisco, CA, May 2009.
31. "Overview of U.S. LED & SSL Standards", Strategies in Lights, Santa Clara, CA, February 2009.
32. "SSL Standardization: LED Component Testing", LED Measurements (by Intertech Pira), October, 2008.

33. "Commercialization of Solid-State Lighting: Standardization", Energy Efficiency and Sustainability Symposium, Atlanta, GA, November 2008.
34. "US LED & SSL Regulation & Standard Activities", The Fifth China Solid-State Lighting Forum, Shenzhen, China, July 2008.
35. "World-Wide LED Forward Lighting Applications", First International Conference on White LEDs and Solid State Lighting, Tokyo, Japan, November 2007.
36. "New Optical Configurations and System Integrations in LED Forward Lighting Applications", The Forth China Solid-State Lighting Forum, Shanghai, China, August 2007.
37. "LED Automotive Lighting in the U.S.", The Third China Solid-State Lighting Forum, Shenzhen, China, July 2006.
38. "LED Automotive Lighting Applications in USA", The Forth International Workshop on Industrial Technologies for Optoelectronic Semiconductor, Gwangju, South Korea, December 2005.
39. "LED Sources in Automotive Exterior Lighting Applications", International Forum on Light Sources for Traffic and Transportation, Wuxi, China, May 2005.
40. "Standardization of LEDs in Automotive Lighting", Strategies in Lights, San Francisco, CA, February 2005.
41. "US LED Automotive Lighting Technical Update", The Third International Workshop on Industrial Technologies for Optoelectronic Semiconductor, Gwangju, South Korea, November 2004.
42. "Automotive Lamp Designs Using LEDs as Light Sources", SPIE 49th Annual Conference, Denver, CO, August 2004.
43. "What is a Good Headlamp", DOT National Highway Transportation Safety Administration (NHTSA) Workshop, Washington, DC, July 2004.
44. "US Automotive Lighting Overview – Competition, Trend, & New Technologies", International Automotive Electronic Technology Development & Application Forum, Shanghai, China, November 2003.
45. "US LED Automotive Lighting – Application Status & Technical Challenges", The Second International Workshop on Industrial Technologies for Optoelectronic Semiconductor, Gwangju, South Korea, November 2003.
46. "New Developments in LEDs for Automotive Market", Strategies in Lights, San Mateo, CA, February 2003.
47. "An Overview of LEDs in Automotive Lighting", Strategies in Lights Workshop, San Mateo, CA, February 2003.
48. "Global Automotive Lighting Technology and Marketing Overview", Invited Lecture, Fu Dan University, Shanghai, China, October 1999.

HONOR & AWARD

Senior Member of SPIE, for recognizing the professional experience, active involvement with the optics community and SPIE, and/or significant performance that sets apart from the peers, 2015.

Arch T. Colwell Cooperative Engineering Medal, for recognizing unique and outstanding contribution over a period of time to the work of the technical committees

Jianzhong Jiao, Ph.D.

750 Van Ness Avenue, Unit 805, San Francisco, CA 94102, 415-606-3322, j_jiao@hotmail.com

under the Technical Standards Board in developing standards, specifications, technical reports and data development through cooperative research, 2010.

SAE Fellow, for recognizing and honoring long-term members who have made a significant impact on society's mobility technology through leadership, research, and innovation, elected in 2008.

Technical Standards Board Outstanding Contribution Award, for recognizing individuals for outstanding service in the technical committee activities of the Society, 2008.

Forest R. McFarland Award, for recognizing individuals for their outstanding contributions toward the work of the SAE Engineering Meetings Board in the planning, development, and dissemination of technical information through technical meetings, conferences, and professional development programs or outstanding contributions to the EMB operations in facilitating or enhancing the interchanges of technical information, 2007, and 2000.

Excellence in Oral Presentation Award, SAE 2005 World Congress, 2005.

[MEMBERSHIP](#)

Member of SAE since 1989, currently SAE Fellow Member
Member of SPIE since 1989, currently SPIE Senior Member
Member of IES since 2007
Member of CIE-USA since 2007