

CHAPTER 11

METERING PRINCIPLES AND PRACTICES

L. W. MANNING

GENERAL INTRODUCTION

The material which is presented in this chapter is confined to the theory and application of the induction watt-hour meter, demand meter, instrument transformers applied with these metering equipments, and meter accessories. Due to the number of induction watt-hour meters required in the electrical industry, considerable space is given to theory of the meters. Also, the theory is of additional importance because of the similarity of induction protective relays to the meters. However, emphasis is placed on application in preference to theory.

The entire revenue of all electrical power plants is derived from the customers served by the individual plant. All customers are billed on energy usage (kilowatt-hours); while the billing of industrial, commercial, and large residential customers may also include demand charges and power factor penalties. Measurement of the quantities, within the close tolerance established by regulating agencies, at a minimum cost is extremely important to the management of each plant and to the individual customer. The economics may be reflected in the rates charged by the utility management to the customer. Also, an error in a particular meter in excess of the established tolerance may represent a considerable sum of money.

Progress in engineering and research has resulted in the development of metering equipment which has laboratory accuracy under all normal operating conditions.^{1,2} Also, by employing efficient quantity production methods and standardization, reliable watt-hour meters are produced and sold at remarkably low prices. An example is the comparison of the watt-hour meter with a wattmeter of comparable accuracy.

I. WATTHOUR METER—GENERAL

1. Requirements of a Watthour Meter

The registration of a watt-hour meter under all normal operating conditions is important to both the utility and the customer. It would be desirable to both parties for the registration to be 100% correct under all conditions. It is usually required by regulating agencies to be within ± 1.0 per cent of 100% registration under specified tests. Under normal operating conditions, the meter may be subjected to variations in line voltage, frequency (including application of complex wave forms), load, load power factor, and temperature. It may also be subjected to abnormal conditions, such as surges due to lightning and system disturbances, and to vibration.³ As a result of its maintained accuracy under both normal

and abnormal conditions, the induction watt-hour meter may be referred to as a versatile, rugged instrument.

If the registration of a watt-hour meter is to be correct, the number of revolutions of the rotating disk, or rotor, N , must be proportional to energy, W . Where C_1 is a constant,

$$N = C_1 W \quad (1)$$

Instantaneous power, $p(t)$ at the points of entry of an electric circuit into a region is the rate at which electric energy is being transmitted by the circuit into the region and is given by

$$p(t) = \frac{dw}{dt} \quad (2a)$$

Conversely, energy is the integral with respect to time of power or

$$W = \int_0^t p(t) dt \quad (2b)$$

The active power, P , at the points of entry of an electric circuit is the time average of the values of instantaneous power, $p(t)$, when the average is taken over a cycle of alternating current. Hence,

$$P = \frac{1}{T} \int_0^T p(t) dt \quad (3)$$

where T is the period of one cycle of fundamental frequency, the total time of an integral number of cycles of fundamental frequency, or a period of time which is much greater than a period of fundamental frequency.

Generally, energy is proportional to the integral with respect to time of power, $p(t)$, or of active power, $P(t)$, because, in general, active power is time variant. Hence,

$$W = \int_0^t P(t) dt \quad (4a)$$

Then, from Equation (1)

$$N = C_1 \int_0^t P(t) dt \quad (4b)$$

For a steady load or constant active power, P , energy is proportional to time or

$$W = P t \quad (5a)$$

Then,

$$N = C_1 P t \quad (5b)$$

The speed of the rotating disk of a watt-hour meter is the time rate of change of the revolutions of the disk. Therefore,

$$s = \frac{dN}{dt} = C_1 p(t) \quad (6)$$

where s is the speed of the disk.

For correct registration of the meter, the speed of the disk must be directly proportional to power. For repetitive time variant voltage and current, the average power is constant; hence, the average speed must be constant. Also, for a constant average speed, the average retarding torque and average driving torque must be equal and directly proportional to average power. Therefore, for correct registration of a meter, two requirements which must be satisfied are: 1) the speed must be directly proportional to average power, and 2) the retarding torque must be directly proportional to speed. If both requirements are satisfied, the average driving torque and average retarding torque are directly proportional to average power delivered to the load.

2. General Construction of an Induction Watthour Meter

An isometric view of a typical single-phase, induction watthour meter is shown in Fig. 1 to indicate general physical arrangement of the basic components. Four basic and essential mechanisms of a watthour meter are: 1) the driving mechanism, which is the electromagnet, 2) the retarding mechanism, which is two permanent magnets, 3) the register mechanism, which is geared to the rotating disk and registers the energy measurement by totaling the number of revolutions of the disk, and 4) the rotor or rotating disk common to all mechanisms, which is essentially the coupling between the other mechanisms. All single-phase meters contain one of each of the above mechanisms. Polyphase watthour meters contain one or more of each of the mechanisms.

The electromagnet, which is usually referred to as the stator, consists of the magnetic core, the potential coil, the current coils, and the variable coils. Magnetic cores of modern meters have one potential pole and two current poles, with the potential and current poles located on opposite sides of the disk air gap. The potential and current coils are wound around the respective poles. Adjustable coils are placed in the face of the potential poles piece and around each of the current poles for calibration of the meter.

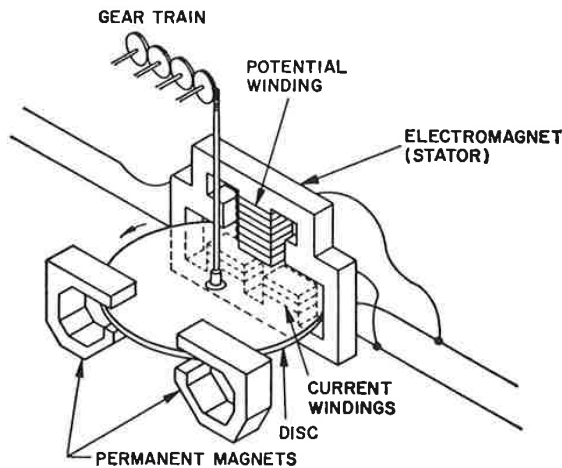

Fig. 1—Isometric view of single-phase, induction watthour meter.

The rotating element is a thin, stippled aluminum disk which is supported by bearings on the supporting frame and is free to rotate in a plane lying in the air gap between the faces of the potential and current poles. Two very small anti-creep holes are located, one on either side of the spindle. When passing through the potential flux field, the holes prevent the disk from creeping under no load conditions.

The permanent magnets are located on the opposite side of the spindle from the electromagnet and serve to introduce an intentional drag on the rotating disk, which is proportional to the speed of the disk. The permanent magnets are so arranged that poles of unlike polarities are on the same side of the disk and only a portion of the flux passes through the disk. Experience has shown that this arrangement produces the greatest drag because of the shunt paths for the eddy current.

The register mechanism consists of a gear reduction mechanism to which is fixed four or five pointers, and

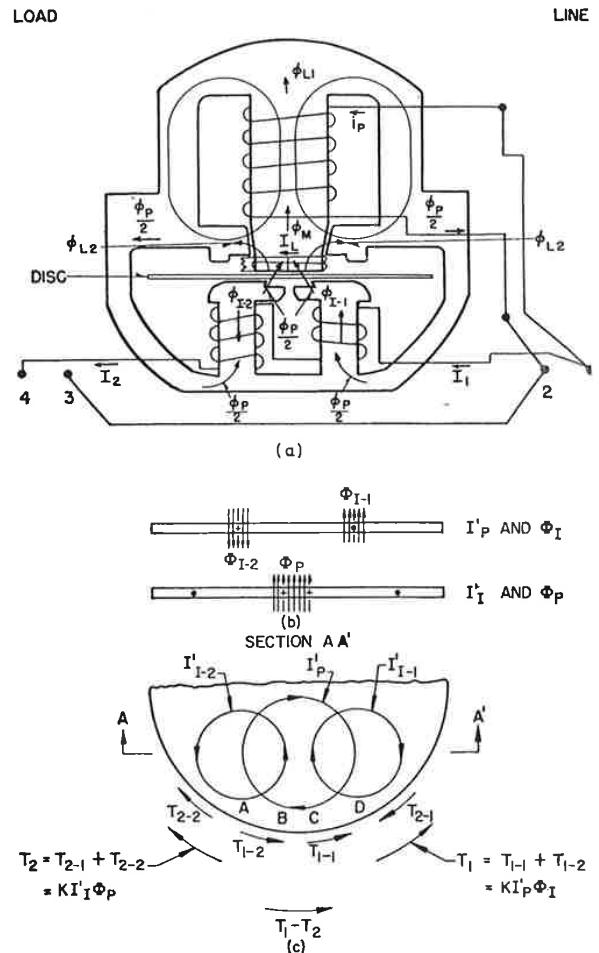

Fig. 2—Schematic diagram of watthour meter (a) Electro-magnet and rotor, (b) Elevation section of disk, showing representations of paths of eddy currents due to potential and current flux, (c) Plan of disk showing interaction of eddy currents and fluxes.

which has a 10:1 reduction between adjacent pointers. The pointers indicate the cumulative number of revolutions of the rotor or the energy measurement. The registration is indicated in kilowatt-hours. The register mechanism is discussed further under "Meter Constants and Test Data."

II. WATTHOUR METER THEORY^{3,4,5,6}

The approach taken in this analysis of an induction watt-hour meter seeks to analyze each mechanism in its particular function in the operation of the meter. A single-phase meter is analyzed here; however, the analysis is applicable to polyphase meters by considering each stator independently.

3. Electromagnet

A schematic diagram of the electromagnet (stator) and rotating disk are shown in Fig. 2. A sectional view of the disk is shown twice in Fig. 2(b) to indicate the eddy current paths in the disk due to the potential flux and the current flux. A partial plan view is shown in Fig. 2(c) to indicate the regions of interactions of the disk eddy currents and fluxes which produce driving torques. The positive direction for all quantities is shown by arrows. The positive direction of voltage drop in the potential circuit is shown by an arrow in the direction of voltage drop. A simplified vector diagram applicable to Fig. 2 is shown in Fig. 3.

The following notation is applicable to Figs. 2 and 3.

- V = voltage applied to meter potential circuit
- I = load current flowing in each meter current winding
- θ = angle by which load current lags the applied voltage
- Φ_{I-1} and Φ_{I-2} = effective flux normal to disk which is due to load current in current windings 1 and 2, respectively
- Φ_p = effective flux normal to disk which is due to applied voltage, V

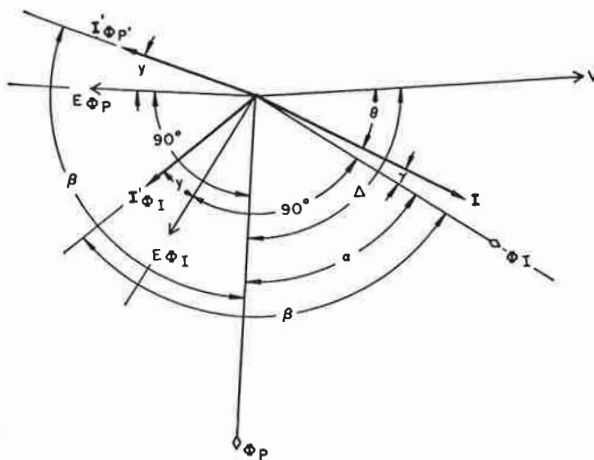

Fig. 3—Vector diagram of circuit shown in Fig. 2.

- E_{Φ_p} = voltage induced in disk by change in I_p
- E_{Φ_I} = voltage induced in disk by change in Φ_I
- I'_{Φ_p} = eddy current in disk due to E_{Φ_p}
- $I'_{\Phi_{I-1}}$ and $I'_{\Phi_{I-2}}$ = eddy current in disk due to $E_{\Phi_{I-1}}$
- y = impedance angle of disk, approximately 18°
- α = angle by which Φ_{I-1} and Φ_{I-2} leads Φ_p
- β = angle by which I'_{Φ_p} lags Φ_p and $I'_{\Phi_{I-1}}$ lags Φ_{I-1}
- Δ = angle by which Φ_p lags V
- γ = angle by which Φ_{I-1} and Φ_{I-2} lag I

As can be seen from Figs. 2(b) and 2(c), three distinct fluxes and three corresponding eddy currents are present in the disk. Four points, A, B, C, and D, exist at which eddy currents flow in a flux other than the flux which causes the eddy currents. A torque is developed at each of the four points, due to the interaction of the eddy current and flux. The four torques developed are as follows:

- At point A, I'_p and Φ_{I-2} produce torque T_{2-2} to the left (clockwise)
- At point B, I'_{I-2} and Φ_p produce torque T_{1-2} to the right (counterclockwise)
- At point C, I'_{I-1} and Φ_p produce torque T_{1-1} to the right (counterclockwise)
- At point D, I'_p and Φ_{I-1} produce torque T_{2-1} to the right (clockwise)

An analysis of the interaction of the eddy currents and flux results in positive values of T_{1-1} and T_{1-2} and negative values of T_{2-1} and T_{2-2} . If symmetry, constant frequency, and sinusoids are assumed, the net average driving torque, T_N , is given by

$$T_N = K\Phi_p\Phi_I \cos y \sin (\Delta - \theta - \gamma) \tag{7}$$

where K = a constant of proportionality. If linear circuits are assumed, Φ_p is directly proportional to V and Φ_{I-1} and Φ_{I-2} are proportional to the load current, I . Then, for a constant frequency

$$T_N = C VI \sin \beta \sin \alpha \tag{8}$$

where

$$\alpha = (\Delta - \theta - \gamma)$$

and

$$\beta = 90^\circ + y \text{ (constant for a particular meter)}$$

From Equation 8

$$T_N = C' VI \sin \alpha \tag{9}$$

where

$$C' = C \sin \beta$$

Since the power delivered to the load is $|V||I| \cos \theta$, the driving torque is proportional to the load only if

$$\begin{aligned} \sin \alpha &= \cos \theta \text{ or} \\ \sin (\Delta - \theta - \gamma) &= \cos \theta \end{aligned}$$

This relationship must hold at all power factors. Also, since $\sin (90 - \theta) = \cos \theta$, $(\Delta - \gamma)$ must equal 90 degrees at all power factors. Due to core losses in both the potential and current circuits, the angle $(\Delta - \gamma)$ would be less than 90 degrees unless means are provided for increasing the angle by which Φ_p lags V . This is referred to as "lagging the meter" and is provided in all induction watt-hour meters by placing a closed-circuit coil, which is adjustable radially with respect to

the disk, on the potential pole piece near the disk or in the face of the pole piece. The per cent registration as a function lagging error and power factor is given by

$$\% \text{ Reg} = (\cos \delta + \tan \theta \sin \delta + \frac{1 - \cos \delta}{\cos \theta}) \times 100 \quad (10)$$

where:

δ = angle of overlagging

θ = angle by which the load current lags the line voltage

In the derivation of Equation 10, it was assumed that the meter registers correctly at unity pf. The seriousness of a lagging error is shown in Fig. 4, which is a plot of Equation 10.

An error in lagging which might be negligible near unity pf becomes increasingly serious as the pf departs from unity. This factor is particularly important in reactive metering, because the voltage applied to the reactive meter lags the line voltage by 90 degrees. A high pf load appears as low pf load to the watthour meter used for reactive metering. If θ in Equation 10 is replaced by $(90^\circ - \theta)$, the equation gives the per cent registration of a varhour meter, which is overlagged by δ and which has been calibrated as a watthour meter to register correctly at unity pf.

In testing a watthour meter to be applied as a reactive meter, the meter may be tested as a watthour meter with watthour potentials applied to the meter, or it may be tested as a reactive meter with the phase displacement transformers. This factor is emphasized in polyphase meter applications, because the power factor apparent to each stator may be considerably different from the system power factor. This condition is apt to exist in polyphase watthour and reactive metering applications. Although correct lagging of a watthour meter is particularly important in polyphase and reactive metering applications, it is of little concern in the application of modern meters which are permanently lagged.

A shading coil which is adjustable in a tangential direction with respect to the disk causes a flux which leads the potential mutual flux in time- and space-phase. This results in a rotating field across the disk and a voltage only driving torque in the direction of the shad-

ing coil from the normal center of the potential flux field. This is the light load adjustment.

Torque Due To Alternating Fields—The retarding torque due to movement of the disk through the alternating flux fields accounts for about four and one-half per cent of the total retarding torque at full load. About four per cent is due to the potential or shunt field. The remaining one-half of one per cent is due to the current or series fields. The torque due to each field is proportional to the speed and to the square of the flux in each respective field, or is proportional to $(\phi^2 + \phi_p^2) S$. The variation in the absolute value of torque due the potential flux is nearly proportional to speed, because the voltage and resulting potential flux do not vary widely. However, torque due to the alternating series (current) fields varies widely and results in low registration of the meter at excessive overloads. The overload range has been extended in modern meters by reducing the normal full load speed of the disk.⁷

Permanent Magnets—The purpose of the permanent magnets is to provide a retarding torque which is directly proportional to the speed of the disk and sufficiently large to overshadow the effects of undesirable characteristics of the unavoidable torques. Let Φ_R be the flux from the permanent magnets which cuts the disk and contributes to the retarding torque, and let S be the speed of the disk. The eddy currents induced in the disk are directly proportional to Φ_R and S . The resulting retarding torque by reaction of those eddy currents and Φ_R is directly proportional to $\Phi_R^2 S$. A reduction of one per cent in Φ_R results in an increase in S of two per cent for the same retarding torque, and a two per cent increase in registration. It is essential that Φ_R remain constant if the retarding torque provided by the permanent magnets is proportional to speed.

The value of Φ_R varies inversely with temperature, while the presence of strong fields due to surges has a demagnetizing effect on the permanent magnets. Therefore, means must be provided either to compensate for normal variations in Φ_R due to these factors or to protect the magnets from these factors.

Errors in registration due to changes in Φ_R caused by temperature changes are referred to as Class I Temperature Errors, or they are non-inductive temperature errors. These errors are independent of the power factor of the load being measured, as contrasted with Class II Temperature Error or inductive temperature errors, which are a function of the power factor of the load.⁷

4. Retarding Torque

In order for a meter to register correctly, the retarding torque must be directly proportional to the speed of the rotating disk. The retarding torque may be segregated into intentional and unavoidable torques.

The unavoidable retarding torque consists of bearing friction, friction in the gear train of the register mechanism, disk windage, and torque due to rotation of the disk in the alternating magnetic flux fields. Not one of these torques meets the necessary requirement of being directly proportional to speed. Consequently, these components are made as small as possible, partially

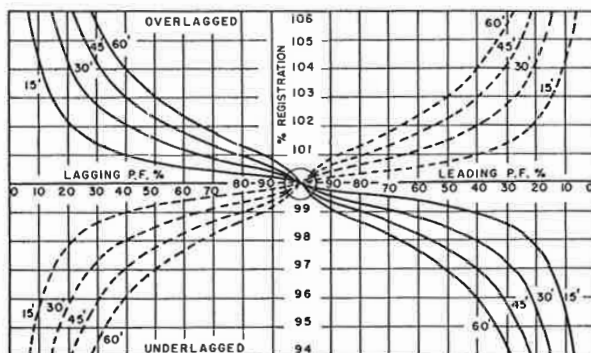

Fig. 4—Registration of watthour as a function of load power factor for various lagging errors. Meter calibrated to register correctly at 1.0 pf.

neutralized by an additional driving torque, or overshadowed in their effort by a large retarding torque of the correct characteristic.

Friction Torque—Friction torque, which is nearly constant, is first made as small as possible. The register gear train and main or lower bearing are the sources of friction, of which the main bearing is the principal source. The friction in the gear train is made small by the use of precision-milled gearing. The three general types of main bearings used in watthour meter designs to reduce the friction at that point are: 1) a polished steel pivot which rotates in a sapphire cup jewel; 2) a polished steel ball which runs between two sapphire cup jewels; and 3) a magnetic suspension bearing in which the rotating disk is held in suspension by two concentric permanent magnets.⁷

The friction retarding torque which remains after careful design of the bearings and gear train is over-compensated for by an additional driving torque developed by shading coil action in the potential circuit of the meter.

Class I Temperature Compensation is provided by a temperature compensating shunt, which is placed on the magnets in such a way as to shunt a portion of the magnet flux from crossing the air gap. The permeability of the shunt varies inversely with temperature, so that as the temperature increases, the proportion of magnet flux which cuts the disk is increased sufficiently to hold the disk flux, Φ_R , constant.

Two designs are used in permanent magnets to reduce the demagnetizing effects of surges. There are: 1) the casting of the magnets from one of the new highly coercive magnetic alloys of aluminum, and 2) plating the magnets with a heavy coating of copper. The first design depends upon the magnet to resist demagnetization due to surges. In the second method, the copper plating shields the magnet by the action of the eddy currents induced in the copper plating by the high fields due to surges. A comparison of the relative effectiveness of the two methods is shown in Fig. 5.

5. The Register

The function of the register is to record the energy as measured by the meter. Essentially it indicates the total number of revolutions of the rotating element, each revolution of which is a measure of energy. It consists of a series of dials geared in a convenient relationship to each other and to the shaft of the rotating disk. The register is shown schematically in Fig. 6.

The gear ratio between adjacent dials shafts, 1, 2, 3, and 4 is one to ten, so that the energy measurements indicated by the respective dials are in units, tens, hundreds, and thousands of kilowatt-hours. The measurement of energy is that which is read from the dials for a direct reading meter or from some other convenient multiplier. The multipliers can result from the additional gear ratio between the shaft of the units dial and the shaft of the rotating element and/or the ratio of instrument transformers applied in the particular installation. It is apparent that a definite total gear ratio exists between the shaft of the rotating disk and

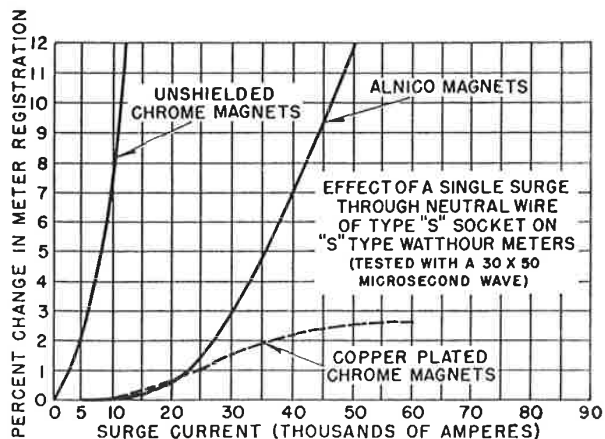

Fig. 5—Effectiveness of surge protection of meter permanent magnets.

the shaft of the “units” pointer for a particular meter having a specific dial multiplier.

The register is a complete and detachable unit driven by the shaft of the rotating element “f”. The proper register to be applied with a particular meter depends upon the load being measured, which would determine the desired dial multiplier. Also, it may be required to replace the usual watthour meter register with a demand register, which would also indicate the maximum demand of the load. This is discussed further under section VI, “Demand Metering”.

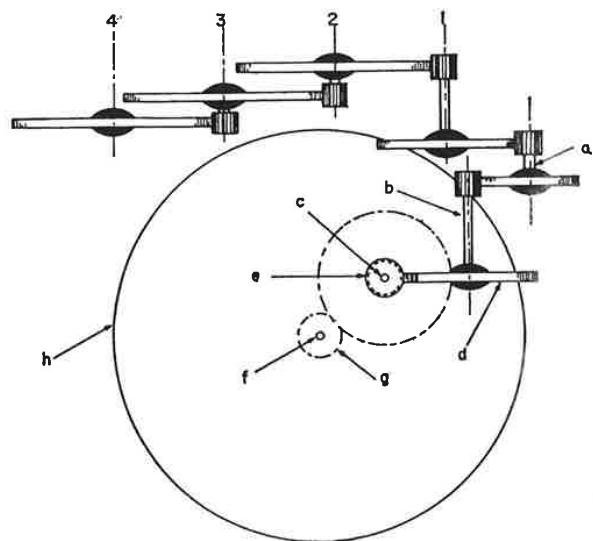

Fig. 6—Schematic view of watthour meter register.

- 1—First pointer shaft
- 2—Second pointer shaft
- 3—Third pointer shaft
- 4—Fourth pointer shaft
- a—Shaft No. 3
- b—Shaft No. 2
- c—Shaft No. 1
- d—Worm gear
- e—Worm
- f—Meter rotor shaft
- g—Meter rotor pinion
- h—Meter rotor (disk)

The essential difference in register designs of various meter manufacturers is in the selection of the point in the gear train at which the worm gear is applied. The indicating dials rotate in a vertical plane, while the disk rotates in a horizontal plane. Therefore, it is necessary to use a worm gear at some point because of this transition. Some manufacturers apply the worm gear at the first gear reduction, where the disk shaft meshes with the register.

III. METER PERFORMANCE, CHARACTERISTICS, AND RATINGS

6. Performance Under Variations in Service Conditions

Frequency—Deviation from rated frequency produces numerous effects in a watthour meter. This can be resolved into changes in currents and fluxes which produce torque. The effects are dependent upon the load current and the load pf. The resulting changes in absolute values (magnitudes) of torque-producing eddy currents and fluxes tend to balance one another out. Errors result from changes in phase relationships which are not balanced out. However, commercial system frequencies are sufficiently constant that the problem is not serious.

7. Wave Form^{10, 11}

In the analysis and application of the induction watthour meter, sinusoidal voltages, fluxes, and currents are usually assumed. Under distorted wave forms, which can be broken down into fundamentals and harmonics, the analysis is applicable if it is realized that the final driving torque is the summation of driving torques due to the various harmonics. A particular harmonic in the flux wave reacts only with the same harmonic in the eddy current wave to produce a driving torque. However, it should be realized that all harmonics of the fluxes are effective in the retarding torques, due to the disk's moving through the alternating fields. It should be realized that the applied voltage and the torque producing potential flux are not necessarily of the same wave forms. Also, the disk eddy currents and the flux causing these eddy currents may not be of the same wave form. On commercial systems, the voltage wave forms are usually sufficiently sinusoidal to be considered as such. However, in energy measurements in non-linear circuits, the current wave form may be sufficiently distorted to be a source of error. This fact should be considered in the measurements in non-linear and rectifier circuits.

Voltage—A deviation in applied voltage affects the saturation and losses of the potential circuits, the lagging of the meter, the driving torque produced by the potential shading coil, and the retarding torque due to movement of the disk in the potential alternating flux. The net effect in meter registration is dependent upon the relative effects on each torque. The retarding torque is proportional to the square of the potential flux, which in turn is proportional to voltage. An increase in voltage results in an increase in losses and a

decrease in lagging. The driving torque due to the shading coil is also proportional to the square of the voltage. A ten per cent change in voltage results in less than 0.8 per cent error in registration, while 2.5 to 30 per cent overvoltages result in less than 1.0 per cent error in registration. Greater than 30 per cent overvoltages may cause serious inaccuracies. However, system voltages do not normally deviate sufficiently from rated voltage to cause serious errors.

The operation of a 240-volt meter at 277 volts is of particular interest in the metering of services which are fed from 265/460-volt network systems. The full-load registration of a modern 240-volt meter, when subjected to abnormally wide variations in applied voltage, is shown in Fig. 7. The meter had previously been calibrated to register correctly at the rated voltage of 240 volts. Although the change in registration with applied voltage is greater when metering unity pf loads, registration is within the usual tolerances over a wide range of applied voltage. The characteristics indicate that a meter calibrated at 240 volts can be applied at 277 volts with satisfactory accuracy; however, the meter might creep at the higher voltage and require resetting of the light load adjustment. Other factors might require application of transformer rated meters at the higher voltage.

Temperature—In modern watthour meters, compensation is provided for Class I and Class II temperature errors.⁸ No compensation is provided for variations in disk temperature; however, such variations would have little effect, since the disk is involved in both driving and retarding torques. A modern temperature-compensated watthour meter will usually provide satisfactory registration within required tolerances from -10°F to 125°F . Ambient temperatures outside this range may justify special consideration.

Summary of Performance Characteristics—Typical performance characteristics of a watthour meter are shown in Fig. 8; however, the characteristic of a particular meter may deviate from those shown.

8. Ratings of Watthour Meters

At the present, two areas of rating watthour meters for application purposes exist. A third area of rating is in the design of meter. The two areas of rating for application purposes are the preferred or available ratings and the standard ratings. The preferred ratings have been established by the needs of the industry, which is

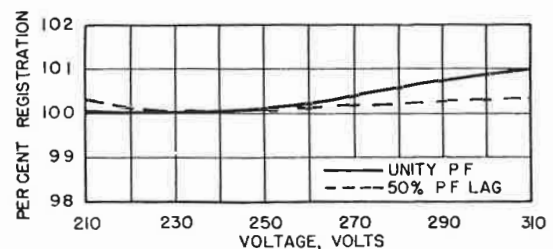

Fig. 7—Registration-voltage characteristic of watthour meter over abnormally wide range of voltage.

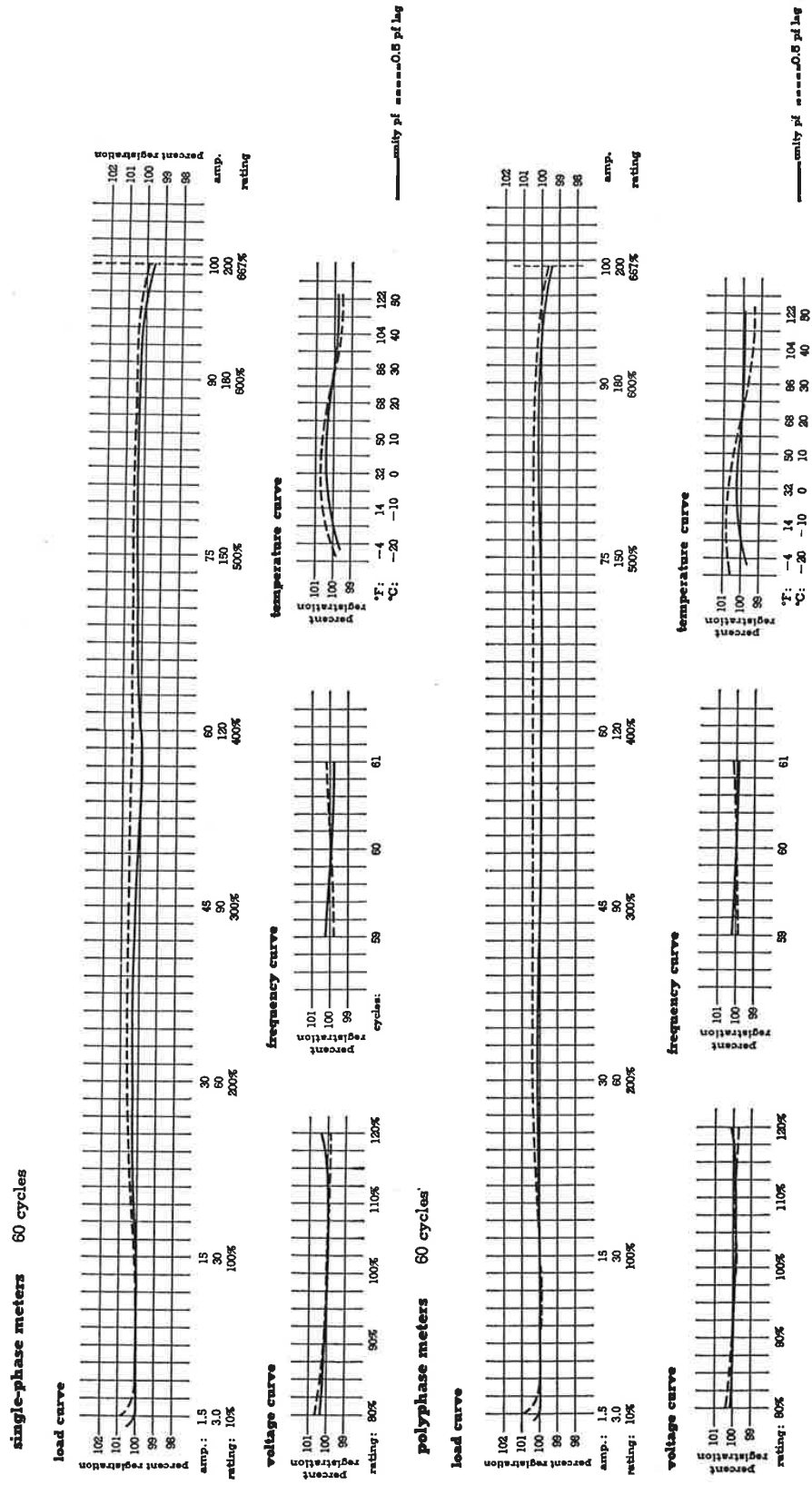

Fig. 8—Typical characteristics of induction watt-hour meter.

the basis for standards. However, only the single-phase, detachable, and bottom-connected meters have been standardized.¹²

The usual ratings applied to a meter are voltage, current, and frequency. So for a system frequency, the meters are rated in voltage and current to agree with the load being metered. For design purposes, each stator is also rated in kilowatts. The voltage, current, and kw rating of single stator meters agree with the respective load quantities. However, this does not generally apply to polyphase meters.

Ratings of polyphase meters require special considerations. For a specific polyphase watt-hour meter, the same voltage and current ratings do not necessarily apply to all stators. However, the kw ratings of all stators are usually equal. This is necessary since the watt-hour constant, K_h , applies to any or all stators. For application purposes, a polyphase meter is given a voltage and current rating. Since the stators are rated equally in kw and equal voltages are not necessarily applied to each stator, the voltage and current rating of a stator may differ from the respective ratings of the meter. This condition exists in the two-stator meters for application on three-phase, four-wire wye systems, and for meters applied to three-phase, four-wire delta systems.

The voltage rating of a meter for a particular application depends upon the type of system from which the load to be metered is served. For self-contained meters applied on a three-phase, three-wire system, the meter is rated at line-to-line voltage. For metering a load served from a three-phase, four-wire wye system, the meter is rated at line-to-neutral voltage. A meter rated at line-to-line voltage is applied on three-phase, four-wire delta systems.

Preferred Ratings—The preferred or available ratings of meters for applications to various systems are shown in Table I.

Standard Ratings—Single-phase, detachable and bottom-connected watt-hour meters are given in AEIC-EEI-NEMA Standards for Watt-hour Meters.

Standard Voltage and Frequency Ratings—The standard voltage ratings are 120, 240, and 480 volts. The standard frequency rating is 60 cps.

Standard Current Ratings—Two standard current ratings are applicable to each meter.¹² The Class (CL) designation of a watt-hour meter denotes the maximum of the load range in amperes. The standard class ratings are 10 (for transformer rated meters), 100, and 200. The Test Current (TA) rating of a meter corresponds with the value of current at which the watt-hour meter is calibrated for operation over its load range. The TA rating corresponds with the current rating of watt-hour meters not covered by the existing standards, and the current rating of single-phase meters according to methods applied prior to standardizing the ratings. The standard TA ratings of single-phase, detachable and bottom-connected watt-hour meters are:

- Class 10—2.5 amperes
- Class 100—15 amperes
- Class 200—50 or 30 amperes.

Other values of current may be recommended as a base test current by a manufacturer.

IV. WATTHOUR METER APPLICATIONS^{4,5,14,15}

In this discussion on meter applications, it is assumed that each meter stator has been adjusted to read correctly; i.e., the driving torque is proportional to power delivered to the load, and the speed is always proportional to power. Having made this assumption, it is unnecessary to include "time" in the equation applying to the application.

Also, the scalar or dot product of vectors is used here in preference to trigonometric functions for simplicity in the analysis of the connections of a particular meter and the resulting registration.⁵ The quantities applied to a watt-hour meter, voltage, and current, can be represented on vector diagrams as co-planar vectors, vectors rotating at a fixed frequency in a common plane, or phasors. The scalar or dot product is equally applicable to phasors.

9. A Scalar or Dot Product of Phasors (Vectors)^{5,16}

The dot product of two phasors, V and I , is defined as $V \cdot I$.

$$V \cdot I \equiv |V| |I| \cos \theta$$

where $|V|$ = the absolute value of the voltage phasor, V
 $|I|$ = the absolute value of the current phasor, I
 θ = the angle between the two phasors, V and I

For this analysis of watt-hour meter applications,

V = the phasor voltage drop in the load in a positive direction. It is also the voltage applied to the potential element of the watt-hour.

I = the phasor current into the load in a positive direction and through the meter in a positive direction to produce forward torque in the meter.

$|V|$ = the rms or effective value of V

$|I|$ = the rms or effective value of I

θ = the phase angle by which I lags V

The quantities V and I are assumed to be sinusoidally time variant at the same frequency.

APPLICABILITY OF DOT PRODUCT TO LAWS OF ALGEBRA

Commutative Law

$$V \cdot I = |V| |I| \cos \theta \quad (a)$$

$$V \cdot I = |I| |V| \cos \theta \quad (b) \quad (11)$$

$$\therefore V \cdot I = I \cdot V \quad (c)$$

Distributive Law

Assume three phasors V , I_1 , and I_2 as shown in Fig. 9

$$(I_1 + I_2) \cdot V = (OB) V \quad (a)$$

Since $OB = OA + AB$,

$$(I_1 + I_2) \cdot V = (OA + AB) V = (OA) V + (AB) V \quad (b) \quad (12)$$

but

$$I_1 \cdot V = (OA) V \quad (c)$$

and

$$I_2 \cdot V = (AB) V \quad (d)$$

$$\therefore (I_1 + I_2) \cdot V = I_1 \cdot V + I_2 \cdot V \quad (e)$$

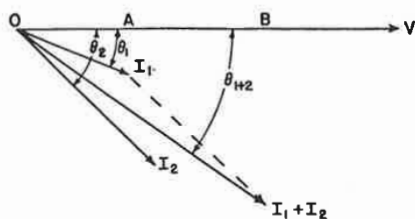

Fig. 9—Vector diagram for showing applicability of a dot product to the distributive law of algebra.

Assume four phasors V_1 , V_2 , I_1 , and I_2 as shown in Fig. 10.

By the Commutative Law

$$(V_1 + V_2) \cdot (I_1 + I_2) = (I_1 + I_2) \cdot (V_1 + V_2) \quad (a)$$

By the Distributive Law

$$(V_1 + V_2) \cdot (I_1 + I_2) = (V_1 + V_2) \cdot I_1 + (V_1 + V_2) \cdot I_2 \quad (b)$$

and

$$(V_1 + V_2) \cdot I_1 = V_1 \cdot I_1 + V_2 \cdot I_1 \quad (c)$$

Similarly

$$(V_1 + V_2) \cdot I_2 = V_1 \cdot I_2 + V_2 \cdot I_2 \quad (d)$$

$$\therefore (V_1 + V_2) \cdot (I_1 + I_2) = V_1 \cdot I_1 + V_1 \cdot I_2 + V_2 \cdot I_1 + V_2 \cdot I_2 \quad (e)$$

10. Blondel's Theorem

Blondel's Theorem applies to the measurement of power flowing into a network of any number of wires, with no restrictions on the number of phases or wires or the balance of load distribution among the phases. It is stated as follows: "If energy is supplied to a network through a wire, the total power in the system is

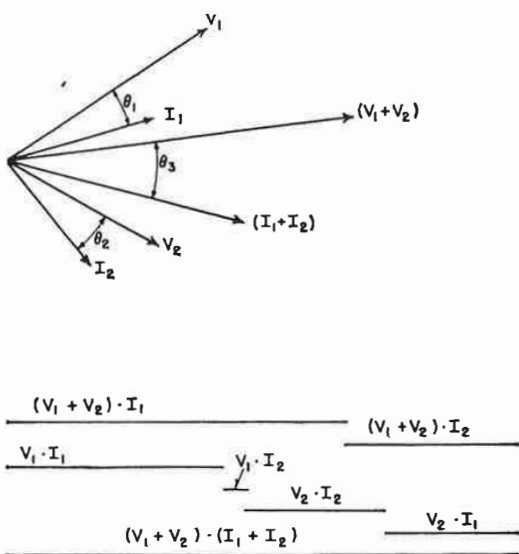

Fig. 10—Vector diagram for showing applicability of a dot product to the cumulative and distributive laws of algebra.

given by the algebraic sum of the readings of n wattmeters, so arranged that each of the n wires contains one current coil, the corresponding potential coil being connected between that wire and a point on the system that is common to all the potential circuits. If this circuit point is on one of the n wires and coincides with the point of attachment of the potential lead to that wire, only $n-1$ wattmeters are required.

"The receiving and generating circuits may be arranged in any desired manner, and no assumption is made as to the way in which the voltage and currents vary."¹⁷

Applying this theorem, the minimum number of single-stator, two-wire meters with which energy delivered to a service on n wires can be accurately measured under general conditions is $n-1$.

11. Application Data

In the analyses presented here for the various meter connections, VI is defined as and understood to indicate a dot or scalar product of the two phasors, unless it is expressly written as otherwise.

The analyses of connections are given for the general case, or any condition of power factor, voltage balance, or load balance. Generally unbalanced loading is assumed. The condition of generally unbalanced voltages, and the special condition of balanced voltages, are both considered in each case.

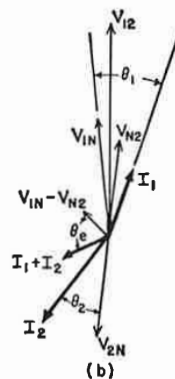
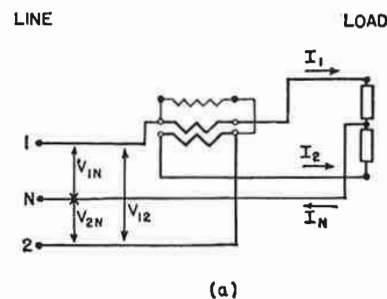

Fig. 11—Metering a single-phase, three-wire circuit (a) Circuit diagram of connections, (b) Vector diagram.

Table 1A—Preferred Ratings of Induction Watt-hour Meters

Application No.	Circuit Application Type of Circuit	Rating of Meter Type	Nominal Voltage	Test Current Rating of Meter	Type of Meter	Westinghouse Designation of Bottom Socket	Number of Connected Stators	Types of Stators	Voltage Rating of Stators	Voltage Applied to Stators	Remarks
1	1- ϕ , 2-wire	SC	E	15	1	DS	1	2-wire	E	E	Universal meter. Potential windings in parallel and use one current winding only.
				15	1	DS	1	2-3-wire	E	E	
				2.5	1	DS	1	2-wire	E	E	
2	1- ϕ , 3-wire	SC	E/2E	15	1	DA	1	3-wire	2E	2E	Applicable to 1- ϕ , 3-wire systems with balanced L-N voltages.
				30	1	DS	1	3-wire	2E	2E	
				50	1	DS	1	3-wire	2E	2E	
				15	1	DS	1	2-3-wire	2E	2E	
				2.5	1	DS	1	2-wire	2E	2E	
3	2- ϕ , 3-wire (Network)	SC	E	15	5	DS-5	2	2-wire	E	E	Universal meter. Potential windings in series and use both current windings (one in series with each line (not neutral) conductor). Applicable to 1-3-wire systems with balanced L-N voltages. Use one 2-wire stator meter on one 3-wire CT or with two 2-wire CT's, secondaries in series or one 3-wire stator meter with two 2-wire CT's connected to corresponding current coil meter. Using CT's only.
				30	5	DS-5	2	2-wire	E	E	
				50	5	DS-5	2	2-wire	E	E	
				2.5	2	DSP-2	2	2-wire	E	E	
				2.5	2	DSP-2	2	2-wire	E	E	
				15	5	DS-5	2	2-wire	E	E	
				30	5	DS-5	2	2-wire	E	E	
				50	5	DS-5	2	2-wire	E	E	
				2.5	2	DSP-2	2	2-wire	E	E	
				2.5	2	DSP-2	2	2-wire	E	E	
4	3- ϕ , 3-wire wye or delta.	SC	E(L-L)	15	2	DSP-2	2	2-wire	E	E	Applicable to 1- ϕ , 3-wire systems with unbalanced L-N voltages. Terminals provided for neutral connection to potential windings. Using two 2-wire CT's only.
				30	2	DSP-2	2	2-wire	E	E	
				50	2	DSP-2	2	2-wire	E	E	
				2.5	2	DSP-2	2	2-wire	E	E	
				2.5	2	DSP-2	2	2-wire	E	E	
				15	2	DSP-2	2	2-wire	E	E	
				30	2	DSP-2	2	2-wire	E	E	
				50	2	DSP-2	2	2-wire	E	E	
				2.5	2	DSP-2	2	2-wire	E	E	
				2.5	2	DSP-2	2	2-wire	E	E	
5	3- ϕ , 4-wire wye	SC	E	15	8	DSP-8	2	3-wire	E	E	For 265/460Y networks meter with stators rated at 240 volts is suitable. Meter has terminal for connection of each potential winding to neutral.
				30	8	DSP-8	2	3-wire	E	E	
				50	8	DSP-8	2	3-wire	E	E	
				2.5	2	DSP-2	2	2-wire	E	E	
				2.5	2	DSP-2	2	2-wire	E	E	
				15	8	DSP-8	2	3-wire	E	E	
				30	8	DSP-8	2	3-wire	E	E	
				50	8	DSP-8	2	3-wire	E	E	
				2.5	2	DSP-2	2	2-wire	E	E	
				2.5	2	DSP-2	2	2-wire	E	E	
6	3- ϕ , 4-wire delta	SC	E	15	7	DSP-7	2	2-wire	E	.867E	So called "3/4 stator" or "Z" connected meter applicable to system with balanced 3- ϕ , L-N voltages. For 265/460Y networks, meter with stators rated at 240 volts are suitable; alternative is to apply 120 meters with two 265/120-volt potential transformers.
				30	7	DSP-7	2	2-wire	E	.867E	
				50	7	DSP-7	2	2-wire	E	.867E	
				2.5	2	DSP-2	2	2-wire	E	E	
				2.5	2	DSP-2	2	2-wire	E	E	
				15	7	DSP-7	2	2-wire	E	.867E	
				30	7	DSP-7	2	2-wire	E	.867E	
				50	7	DSP-7	2	2-wire	E	.867E	
				2.5	2	DSP-2	2	2-wire	E	E	
				2.5	2	DSP-2	2	2-wire	E	E	

Table 1A (cont'd)—Preferred Ratings of Induction Watthour Meters

Application No.	Circuit Application Type of Circuit	Rating of Meter Nominal Voltage	Rating of Meter Type	Test Current Rating of Meter	Westinghouse Designation of Bottom Socket Connected	Number of Stators	Types of Stators	Voltage Rating of Stators	Voltage Applied to Stators	Remarks
7	Totalizing 1- ϕ , 2-wire, and 3- ϕ , 3-wire service	1- ϕ E1 3- ϕ E	SC	1- ϕ E/2	4	CS-4	CA-4	3	2-wire E/2	E/2
			SC	3- ϕ E	7.5	CS-4	CA-4	3	2-2-wire E	E
			TR	1- ϕ E/2	60	CS-4	CA-4	3	2-2-wire E	E
			TR	3- ϕ E	25	CS-4	CA-4	3	2-wire E	E
			TR	1- ϕ E	15	CS-4	CA-4	3	2-2-wire E	E
			TR	3- ϕ E	15	CS-4	CA-4	3	2-2-wire E	E
			TR	1- ϕ E	60	CS-4	CA-4	3	2-2-wire E	E
			TR	3- ϕ E	50	CS-4	CA-4	3	2-2-wire E	E
			TR	1- ϕ E/2	5	CS-4	CA-4	3	2-wire E/2	E/2
			TR	3- ϕ E	2.5	CS-4	CA-4	3	2-wire E	E
8	Totalizing 1- ϕ & 3- ϕ , 3-wire service	1- ϕ (E/2)/E 3- ϕ E	SC	1- ϕ (E/2)/E	6	CS-6	CA-6	3	3-wire E	E
			SC	3- ϕ E	15	CS-6	CA-6	3	2-2-wire E	E
			TR	1- ϕ (E/2)/E	50	CS-6	CA-6	3	2-2-wire E	E
			TR	3- ϕ E	5	CS-6	CA-6	3	3-wire E/2	E/2
			TR	1- ϕ (E/2)/E	5	CS-6	CA-6	3	2-2-wire E	E
			TR	3- ϕ E	5	CS-6	CA-6	3	2-2-wire E	E
			TR	1- ϕ (E/2)/E	15	CS-6	CA-6	3	3-wire (E/2)/E	(E/2)/E
			TR	3- ϕ 2E	7.5	CS-6	CA-6	3	2-2-wire 2E	2E
			TR	1- ϕ (E/2)/E	50	CS-6	CA-6	3	2-2-wire (E/2)/E	(E/2)/E
			TR	3- ϕ 2E	25	CS-6	CA-6	3	2-2-wire 2E	2E
9	2- ϕ , 5-wire	SC TR	SC	1- ϕ (E/2)/E	5	CS-6	CA-6	3	3-wire (E/2)/E	(E/2)/E
			TR	3- ϕ 2E	2.5	CS-6	CA-6	3	2-2-wire 2E	2E
			SC	E	15	CS-10	CA-10	2	2-3-wire E	E
			TR	E	50	CS-10	CA-10	2	2-3-wire E	E
			TR	E	2.5	CS-10	CA-10	2	2-3-wire E	E
			TR	E	50	CS-10	CA-10	2	2-3-wire E	E
			TR	E	2.5	CS-10	CA-10	2	2-3-wire E	E
			TR	E	50	CS-10	CA-10	2	2-3-wire E	E
			TR	E	2.5	CS-10	CA-10	2	2-3-wire E	E
			TR	E	50	CS-10	CA-10	2	2-3-wire E	E

Uses CT's only. Uses three-2-wire CT's (one for 1- ϕ ckt. and two for 3- ϕ ckt.).

Uses CT's only. Uses two 2-wire CT's on 1- ϕ ckt. and two 2-wire CT's for 3- ϕ ckt.; alternate is to use a three 2-wire stator meter (similar to CS-4 or CA-4) and one 3-wire CT on 1- ϕ ckt. and two 2-wire CT's on 3- ϕ ckt.; second alternate is to use a three 2-wire stator meter (similar to CS-3) with three FT's, one 3-wire CT and two 2-wire CT's.

Remarks applicable to TR meter on 1- ϕ E₁/E, 2- ϕ E application above also applicable.

Each stator is similar to 3-wire stator used on 1- ϕ (E/2)/E system. Circuit is essentially two 1- ϕ systems with common neutral. CT's only. Used with four 2-wire CT's. A two 2-wire stator meter similar to (DS-2 or DA-2) can be applied with two 3-wire CT's.

Table 1B—Preferred Voltage Ratings of Induction Watthour Meters

Application No.	Circuit Application	Rating of Meter	Application # Table 1A										
			1	2	3	4	5	6	7	8	9		
SC	TR	SC	TR	SC	TR	SC	TR	SC	TR	SC	TR	SC	TR
120	120	120	120	120	120	120	120	120	120	120	120	120	120
240	240	240	240	240	240	240	240	240	240	240	240	240	240
480	480	480	480	480	480	480	480	480	480	480	480	480	480
600	600	600	600	600	600	600	600	600	600	600	600	600	600

E = Nominal voltage of circuit to which the meter is applied.
SC = Self-contained meter.
TR = Transformer-rated meter.

It is assumed in each application that in the meter being considered, each stator has been adjusted and registers correctly the dot product of voltage and current applied to each stator. Only voltages and currents available for metering are shown in diagrams. Since the meter stators have been assumed to register correctly, the factor of "time" has been omitted from the analyses for simplicity.

Single-Phase, Two-Wire Meter—No analysis is necessary for this application, because this is the basic stator or meter considered under watt-hour meter theory. Also, it has been assumed that the stator has been calibrated for correct registration.

Single-Phase, Three-Wire Circuit—For ordinary commercial and residential loads, the single-phase, three-wire, self-contained meter is used, although some loads may require transformer-rated meters. The meter is connected as shown in Fig. 11(a). In this meter, the two coils on the individual pole pieces are connected opposing each other for positive direction of currents into the loads. The corresponding vector diagram is shown in Fig. 11(b).

Analysis of measurement obtained in single-stator, three-wire meter:

Power delivered to the load is

$$P_t = V_{1N}I_1 + V_{2N}I_2 \quad (a)$$

$$= V_{1N}I_1 - V_{N2}I_2 \quad (14)$$

For balanced voltages

$$V_{1N} = V_{N2} = \frac{V_{12}}{2}$$

Then,

$$P_t = V_{1N}I_1 - V_{1N}I_2 \quad (a)$$

$$= V_{1N} (I_1 - I_2) \quad (b)$$

$$= \frac{V_{12}}{2} (I_1 - I_2) \quad (c)$$

Let the power measured by the meter be P_m . Then,

$$P_m = V_{12} \left(\frac{I_1 - I_2}{2} \right)$$

Division by "2" and "-" sign are necessary, since the three-wire meter has two half-winding current coils of opposite polarity for positive direction of current into the load.

If the voltages to neutral are balanced, the meter registers correctly regardless of any unbalance in load or difference in load power factors. However, since the possibility of voltage unbalance exists, the error in registration which may occur is of interest.¹⁸ Let P_o be the difference between P_t , the true power delivered to the load, and P_m , the power as measured by the meter.

Then

$$P_o = P_t - P_m \quad (a)$$

$$= \frac{1}{2} (V_{1N} - V_{N2}) (I_1 + I_2) \quad (b)$$

P_o is one-half the dot product of the phasors $(V_{1N} - V_{N2})$ and $(I_1 + I_2)$. This expression is of limited usefulness because the unbalance phasors and their phase relation-

ship are not generally known. However, an analysis of the fundamental accuracy of the meter shows that its acceptance is well founded and the error is usually negligible. Where the error due to voltage unbalance is objectionable, a two-stator meter or two single-stator two-wire meters are required to obtain correct registration. Connections for these applications are shown in Fig. 12(a) and Fig. 12(b).

A three-wire single-phase service which requires current transformers can be metered with either a two-wire, single-stator meter or a three-wire single-stator meter. The diagrams of connections for metering a single-phase, three-wire service which requires current transformation are shown in Fig. 13. A three-wire meter requires two current transformers. A two-wire meter can be applied with two current transformers; however, a special three-winding current transformer, which is usually more economical, is available for metering three-wire, single-phase service with a two-wire meter.

A combination self-contained, two-wire, three-wire, single-phase meter is suitable for application on a 120-volt, two-wire service or on a 240-volt, three-wire service. The current coils are similar to those in a three-wire meter. The potential winding is split into two identical windings, which are connected in parallel for 120-volt, two-wire service, and in series for 240-volt, three-wire service. Both current coils are used for three-wire metering. For two-wire service, only one current coil is used; the other coil is disconnected and bridged. The meter watt-hour constant is the same for both the

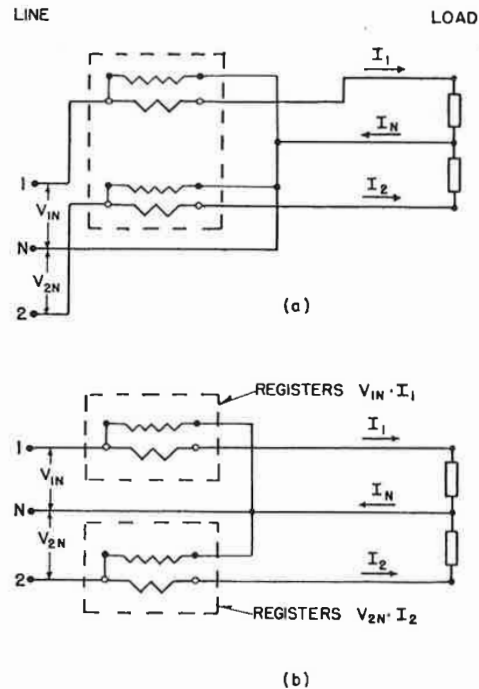
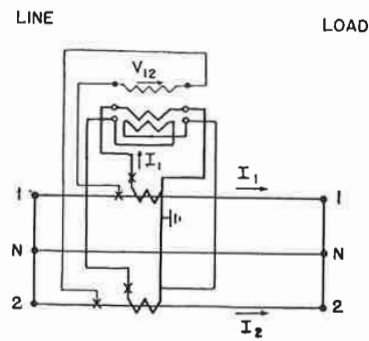
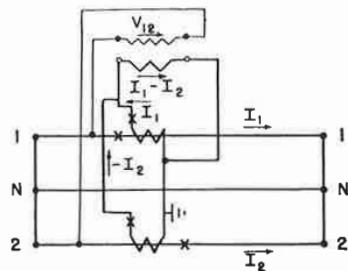

Fig. 12—Diagrams of connections for metering a single-phase, three-wire service where line-to-neutral voltages are unbalanced. (a) Using a two-stator meter, (b) Using two single-stator meters.



(a)



(b)

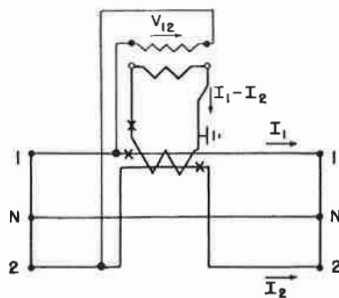

(c)

Fig. 13—Diagram of connections of transformer rated single-phase, three-wire meter. (a) Three-wire meter and two two-wire CT's (b) Two-wire meter and two two-wire CT's, (c) Two-wire meter and three-wire CT.

120-volt and 240-volt connections, because the potential flux is essentially the same for either connection.

Three-Phase, Three-Wire Circuit—According to Blondel's Theorem, a three-phase, three-wire circuit requires two meters of a two-stator meter for measurement of energy. The circuit diagram for measurement of energy (or power) in either a three-phase, three-wire delta or wye circuit is shown in Fig. 14(a). The load might be any one of these types of circuits. Hence, the delta load is indicated by solid lines; dotted lines indicate alternate loads. The metering shown in Fig. 14(a) may be either a

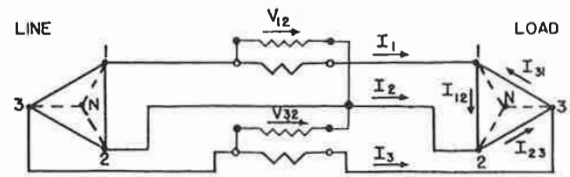

(a)

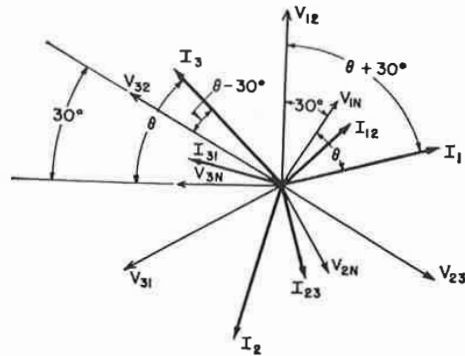

(b)

Fig. 14—Metering a three-phase, three-wire circuit, (a) diagram of connections, (b) vector diagram.

two-stator meter or two single-stator meters. Note that a meter current coil is in each of two-phase conductors, and that the potential coils are connected between the conductor containing the related current coil and the phase conductor which does not contain a current coil. Such a connection is required in order for the energy measurement to be made with $n-1$ meters or stators.

The vector diagram for Fig. 14(a) is shown in Fig. 14(b). Delta currents, indicated by double subscripts, are not applicable to the wye circuit.

Analysis of the applicability of the circuit represented by the diagram shown in Fig. 14(a) to three-phase, 3-wire circuits is as follows: The phasors are as shown on the vector diagrams of Fig. 14(b).

(1) For Delta

$$I_1 = I_{12} - I_{31} \quad (a)$$

$$I_2 = I_{23} - I_{12} \quad (b)$$

$$I_3 = I_{31} - I_{23} \quad (c) \quad (17)$$

$$V_{12} + V_{23} + V_{31} = 0 \text{ and } I_1 + I_2 + I_3 = 0 \quad (d)$$

$$P = V_{12} I_{12} + V_{23} I_{23} + V_{31} I_{31} \quad (a)$$

$$P = V_{12} I_{12} - V_{32} I_{23} - (V_{12} - V_{32}) I_{31} \quad (b)$$

$$P = V_{12} (I_{12} - I_{31}) + V_{32} (I_{31} - I_{23}) \quad (c) \quad (18)$$

$$P = V_{12} I_1 + V_{32} I_3 = \text{Meter Registration} \quad (d)$$

(2) For Wye

$$P = V_{1N} I_1 + V_{2N} I_2 + V_{3N} I_3 \quad (a)$$

$$P = V_{1N} I_1 - V_{2N} (I_1 + I_3) + V_{3N} I_3 \quad (b) \quad (19)$$

$$= (V_{1N} - V_{2N}) I_1 + (V_{3N} - V_{2N}) I_3 \quad (c)$$

$$= V_{12} I_1 + V_{32} I_3$$

Two-Phase, Three-Wire Network Circuits—According to Blondel's Theorem, the two-phase, three-wire network service requires either a two-stator meter or two single-stator meters, as shown in Fig. 15(a). The vector diagram is shown in Fig. 15(b). Attention is directed to some peculiarities in the metering of a two-phase, three-wire network service. It has been shown that a two-stator meter registers correctly when applied on a three-wire, three-phase circuit, if line-to-line potentials are applied to the meter. It registers equally well on a two-phase, three-wire neutral service fed from a three-phase, four-wire wye system, if line-to-neutral potentials are applied to the meter. Then each stator measures the load on the respective phase to which it is connected. The analysis of the applicability of the network meter follows:

$$P_1 = V_{1N} \cdot I_1 \text{ and } P_2 = V_{2N} \cdot I_2 \quad (a)$$

$$P = P_1 + P_2 = V_{1N}I_1 + V_{2N}I_2 \quad (b) \quad (20)$$

For line-to-line loads, the registration on each stator is as follows:

$$\text{Stator \#1, } P_1 = V_{1N} \cdot I \quad (a) \quad (21)$$

$$\text{Stator \#2, } P_2 = V_{2N} \cdot I_2$$

But for line-to-line loads, $I_2 = -I_1$.

Then, $P_2 = V_{2N}I_1$

The net registration is given by

$$P = P_1 + P_2 \quad (a)$$

$$P = (V_{1N} - V_{2N})I_1 \quad (b) \quad (22)$$

$$P = V_{12} \cdot I_1$$

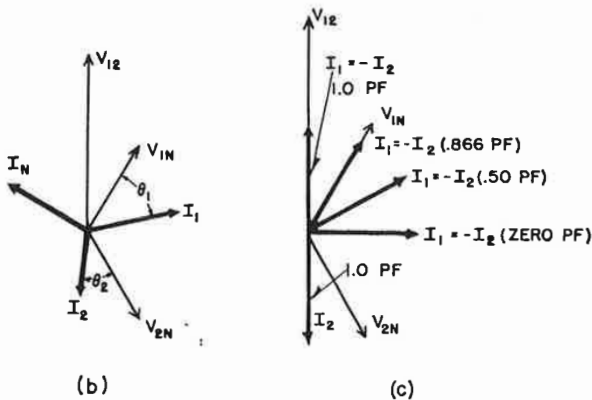
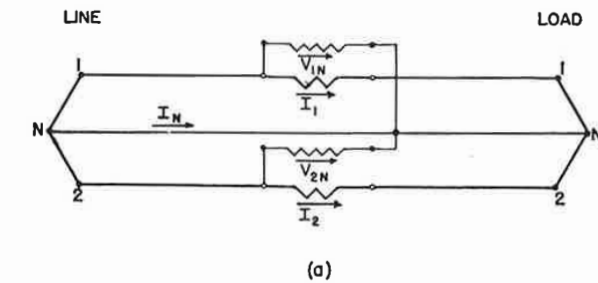

Fig. 15—Metering two-phase, three-wire network circuit, (a) Diagram of connections, (b) Vector diagram, balanced system voltages, unbalanced load, (c) Vector diagram for metering line-to-line loads, balanced system voltages.

Since the true power to the load is $V_{12} \cdot I_1$, the two-stator meter also registers correctly on measurement of line-to-line loads.

The essential differences in the standard two-stator, three-phase, three-wire meter and the network meter are in the terminal connections and in the voltage ratings. The standard two-stator meter usually has completely separate potential and current circuits; therefore, it has eight terminals. The network meter is arranged so that the two potential circuits are connected to a common terminal. The other terminal of each potential circuit is common with a terminal of the respective related current coil. A greater difference in the standard two-stator and network meters is in the voltage ratings of each type and meter. The voltage rating for application to three-phase, three-wire circuits is line-to-line voltage. However, the network meter is rated for line-to-neutral voltage. The network meter is applicable to three-phase, three-wire circuits if the nominal circuit line-to-line voltage is equal to the rated voltage of the meter.

Transformer-rated, three-wire meters for two-phase and three-phase circuits are usually the standard two-stator meter, because meters having completely separate potential and current circuits would be required. The secondary circuits at the current transformers must be grounded; however, line-to-line potential may be applied to the stators, so that no potential terminal can be grounded. The current transformers cannot be grounded when a network meter is used. For reasons of economy and simplicity, a two-stator network meter is recommended where it is applicable in metering three-phase, three-wire circuits.

Attention is directed to the rather interesting peculiarities in metering of two-phase, three-wire network services. These peculiarities are: 1) the action of a two-stator meter when metering line-to-line load on a two-phase, three-wire network service by means of a two-stator meter, and 2) the accuracies of a single-phase, three-wire meter when applied to two-phase, three-wire network circuits.

The measurement of line-to-line loads in a two-stator meter are considered first. The condition of the measurement of line-to-line load should not be confused with the measurement of identical line-to-neutral loads. The two conditions are entirely different. For equal line-to-neutral loads, each load is measured on the proper stator. However, in measurement of line-to-line loads, the torque developed by each stator or the measurement of energy on each stator of a network meter is a function of the phase angle between the phase voltage and the corresponding phase current or line current. The energy consumption in line-to-line loads is a function of the phase angle between line-to-line voltage and phase or line current. This results in a variation in the distribution of driving torque between the meter stators with load power factors. Fig. 15(c) is the vector diagram for line-to-line loads taken from a two-phase, three-wire neutral service. With the aid of Fig. 15(c), the variation in driving torque distribution with load pf can be analyzed.

Although a single-stator, three-wire meter correctly

registers line-to-line network loads, the meter does not register correctly for line-to-neutral loads. The diagram of the circuit considered here is shown in Fig. 16. The vector diagrams for various line-to-neutral load power factors are shown in Fig. 17. Since neither V_{IN} nor V_{2N} is equal to $V_{12}/2$, and I_2 is not equal to $-I_1$, the single-stator, three-wire meter does not register correctly. As an example, consider the vector diagram shown in Fig. 17(a), which is for a unity power factor line-to-neutral load on phase "1".

$$\begin{aligned} \text{True Power} &= V_{IN} \cdot I_1 & (a) \\ &= V_{IN} I_1 \text{ at unity pf.} & (b) \end{aligned} \quad (23)$$

$$\text{Meter registers} = P_m = V_{12} \cdot \frac{I_1}{2} \quad (a)$$

$$P_m = \frac{V_{12} I_1 \cos 30^\circ}{2} \quad (b)$$

$$P_m = \frac{\sqrt{3} V_{IN} I_1}{2} \cdot \frac{\sqrt{3}}{2} \quad (c)$$

$$P_m = .75 V_{IN} I_1 \quad (d)$$

The registration on the meter is 75 per cent. A similar reasoning may be applied to the other load power factors and the following results obtained:

Load Between	Power Factor	Per Cent of Correct Registration
1-N	100%	75%
1-N	86.6% lag	50%
1-N	50.0% lag	0
2-N	100%	75%
2-N	86.6% lag	100%
2-N	59.0% lag	150%

For identical line-to-neutral loads on the two phases, the single-stator, three-wire meter registration is correct only at zero pf and is 75 per cent correct at all other power factors. This can be seen from an analysis of Fig. 18. Balanced line-to-neutral voltages are assumed.

Three-Phase, Four-Wire Wye—According to Blondel's Theorem, a three (n-1) stator meter is required for accurately metering a three-phase, four-wire wye service. However, if the voltages are balanced, the metering is simplified, and the "Z" connection of a two and one-half stator meter is applicable with equal accuracy. For most applications, the voltages are sufficiently balanced to make this assumption valid. This factor is particular-

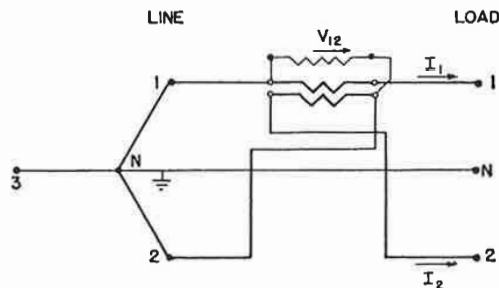

Fig. 16—Diagram of connections for incorrect metering of two-phase, three-wire network circuit with a single-stator, three-wire meter.

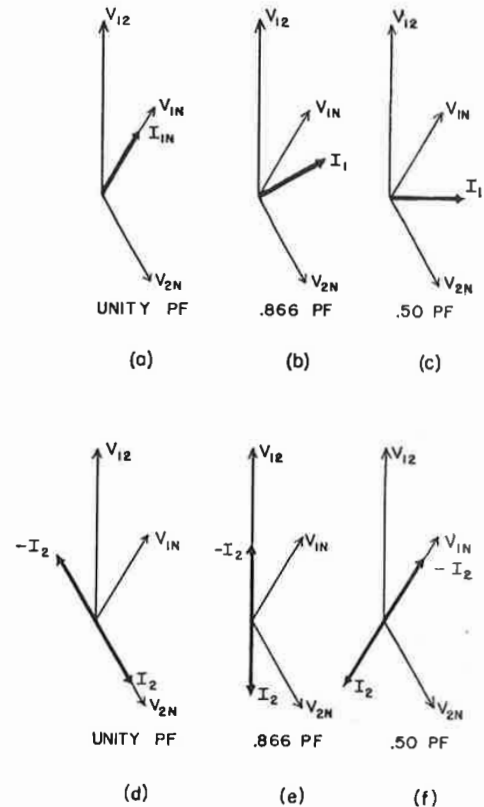

Fig. 17—Vector diagrams for various load power factors for metering line-to-neutral loads on two-phase, three-wire network circuit with a single-stator, three-wire meter.

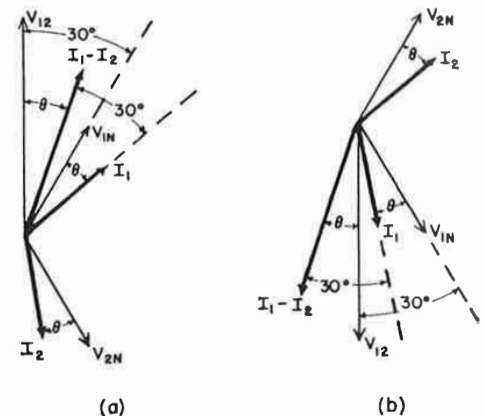

Fig. 18—Vector diagram for metering identical line-to-neutral loads on a two-phase, three-wire network circuit with a single-stator, three-wire meter, (a) Phase sequence 1-2-3, (b) Phase sequence 1-3-2.

$$\begin{aligned} \text{True Power} &= V_{IN} I_1 + V_{2N} I_2 \\ &= 2 V_{IN} I_1 \cos \theta \\ \text{Measure Power} &= \frac{1}{2} V_{12} (I_1 - I_2) \\ &= \frac{\sqrt{3} V_{IN} \sqrt{3} I_1 \cos \theta}{2} \\ \frac{\text{Measure Power}}{\text{True Power}} &= .75 \end{aligned}$$

ly important in the measurement of energy on three-phase, four-wire wye systems which require potential transformers. If the voltages are balanced, only two potential transformers are required for the energy metering. Although the factor is important when low voltage systems are considered, it becomes increasingly important at the higher voltages, due to the increased cost of the potential transformers. The circuit diagram for metering three-phase, four-wire, wye service by a three-stator meter is shown in Fig. 19(a). The circuit diagram for use of the 2½ stator meter is shown in Fig. 19(b). The vector diagram is shown in Fig. 19(c).

Analysis of measurement of three-phase, four-wire, wye circuit shown in Figure 19 is as follows:

$$\text{True Power} = P_T = V_{1N}I_1 + V_{2N}I_2 + V_{3N}I_3 \quad (24)$$

if the voltages are balanced,

$$V_{1N} + V_{2N} + V_{3N} = 0 \quad (a)$$

$$P_T = V_{1N}I_1 + V_{2N}I_2 - (V_{1N} + V_{2N})I_3 \quad (b) \quad (25)$$

$$= V_{1N}(I_1 - I_3) + V_{2N}(I_2 - I_3) \quad (c)$$

The 2½ stator or "Z"-connected meter is comprised of two single-phase, three-wire stators driving a common shaft. The current coil in each stator is divided evenly into two windings. One current winding on each stator carries the current of the phase, the voltage of which is applied to the potential coil, while the other current winding of that stator carries the negative of the current of the phase in which the potential is not measured.

Since the current windings on each stator are split into two half-windings and are wound with opposite polarity, the power measurement on a "Z"-connected meter is given by

$$P_M = V_{1N}(I_1 - I_3) + V_{2N}(I_2 - I_3) \quad (a) \quad (26)$$

$$= V_{1N}I_1 + V_{2N}I_2 - (V_{1N} + V_{2N})I_3 \quad (b)$$

This measurement is correct for balanced line-to-neutral voltages. However, the measurement indicated on the meter is as given by Equation 26, regardless of the voltage unbalance. The true power into a three-phase, four-wire, wye circuit is given by Equation 24.

The vector diagram for metering the circuit with a 2½ stator meter under conditions of generally unbalanced voltages is shown in Fig. 20. The error, P_e , in the measurement of power, or the registration of a 2½ stator meter for a condition of unbalanced line-to-neutral voltages is given by

$$P_e = P_T - P_M \quad (a) \quad (27)$$

$$P_e = (V_{1N} + V_{2N} + V_{3N})I_3 \quad (b)$$

$$P_e = V_R I_3 \quad (c)$$

where

$$V_R = V_{1N} + V_{2N} + V_{3N}$$

Therefore, no error occurs from application of a 2½ stator meter on three-phase, four-wire wye system if: (1) the residual voltage to neutral is zero, which occurs if the voltages-to-neutral are unbalanced; (2) the current in the "Z" connected current coils (I_3 above) is zero; and (3) the residual voltage-to-neutral and the current in the "Z" connected current coils are in quadra-

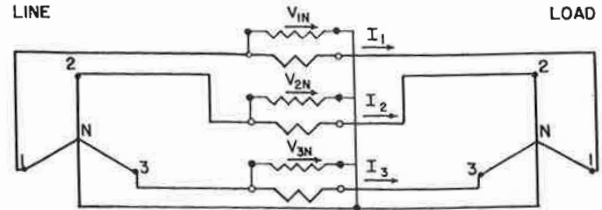

(a)

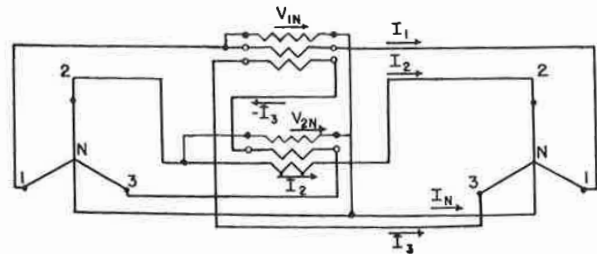

(b)

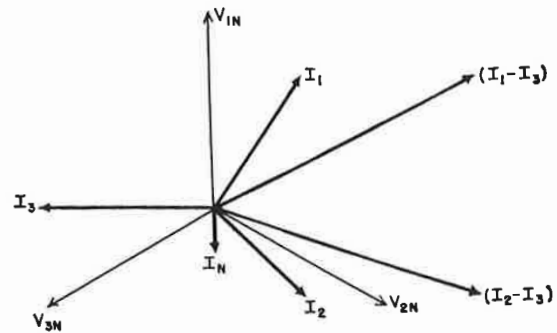

(c)

Fig. 19—Metering of three-phase, four-wire wye circuit, (a) Diagram of connections for using a three-stator meter, (b) Diagram of connections for using a two-stator, "Z" connected meter, (c) Vector diagram.

ture time phase. For applications in which any one of these conditions hold, a 2½ stator meter registers with the same accuracy obtained with a three-stator meter.

The error in a 2½ stator meter occurs in the measurement of load on the phase on which the potential is not applied to the meter. The meter registers correctly the loads on the phases of which both potential and current are applied to the meter.

Some effects of unbalanced voltages on the accuracy of a 2½ stator meter can be seen from Fig. 21. It is assumed that V_{3N} is not applied to the meter. In Fig. 21(a), $-(V_{1N} + V_{2N})$ is in phase with but not equal to V_{3N} . In Fig. 21(b), $-(V_{1N} + V_{2N})$ is equal in magnitude only to V_{3N} . Observe Fig. 21(a) and suppose that if, E_{3N} , is 1.0 per cent lower than $-(V_{1N} + V_{2N})$. Phases "one" and "two" are registered correctly and the measurement on phase "three" will be one per cent high. The

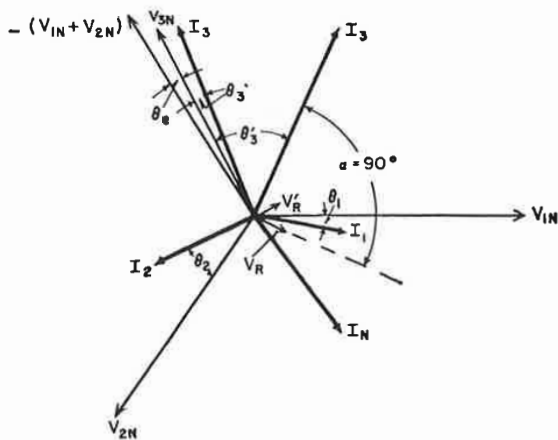

Fig. 20—Vector diagram of circuit for metering a three-phase, four-wire wye circuit with two-stator "Z" connected meter under conditions of generally unbalanced voltages showing factors in error of meter.

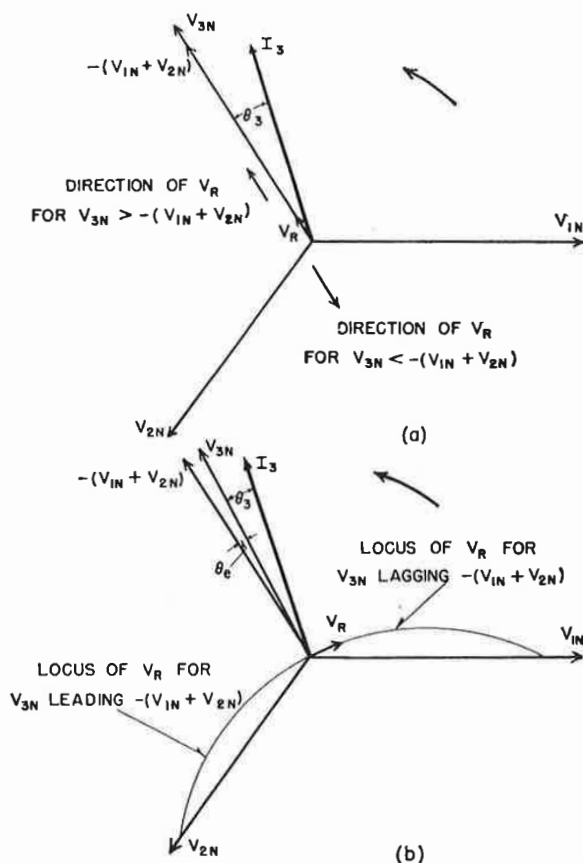

Fig. 21—Vector diagram circuit for metering a three-phase, four-wire wye circuit with "Z" connected meter for analyzing error under various load conditions, (a) $-(V_{1N} + V_{2N})$ in phase with but not equal to V_{3N} , (b) $-(V_{1N} + V_{2N})$ equal in absolute value only to V_{3N} .

total error will then depend on the distribution of the load. The meter registration will be (1) 0.3 per cent high if the load is balanced; (2) one per cent high if only phase "three" is loaded; and (3) correct if the load on phase "three" is zero. For V_{3N} equal in magnitude only to $-(V_{1N} + V_{2N})$, no appreciable error results for load power factor near unity. For load power factor near 50 per cent, an error of 15 minutes [the angle between V_{3N} and $-(V_{1N} + V_{2N})$] will result in the following errors: (1) .75 per cent if only phase "three" is loaded; (2) .25 per cent if the load is balanced; and (3) no error if the load on phase "three" is zero.

Three-Phase, Four-Wire, Delta—The circuit diagrams showing the metering of a three-phase four-wire delta circuit are shown in Fig. 22. The circuit shown in Fig. 22(a) uses a two-stator meter, which has one three-wire stator and one two-wire stator. The circuit shown in Fig. 22(b) uses a meter having three two-wire stators. The circuit is suitable for combined single-phase, three-wire and three-phase, three-wire service. The analysis of metering this type of load is simplified by considering the three-phase and single-phase loads separately, and then superimposing these loads for consideration of the combined load. No assumption is made regarding the balance of load in either the three-phase or single-phase circuits, or the relative magnitudes of the single-phase and total three-phase loads. In order to be generally applicable, unbalanced voltages-to-neutral on

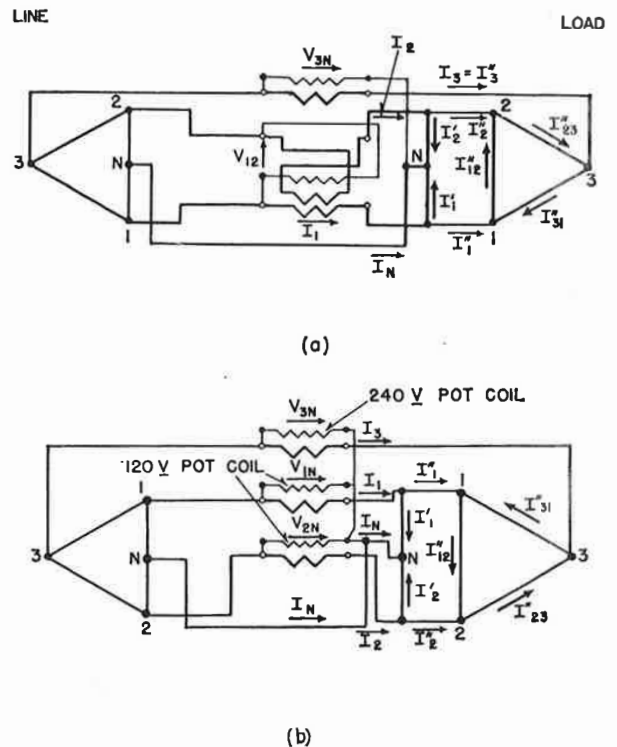

Fig. 22—Diagram of connections for metering a three-phase, four-wire delta circuit with (a) Two-stator meter, (b) Three-stator meter.

the single-phase load is assumed. The accuracy of the metering of the three-phase, three-wire delta loads is not dependent upon balanced line-to-line voltages; however, balanced three-phase voltages are assumed.

The vector diagrams of circuits for metering three-phase, four-wire delta loads are shown in Fig. 23(a). This diagram is similar to the diagram shown in Fig. 14(b), for the three-phase, three-wire circuit. The vector diagram for the single-phase, three-wire load is shown in Fig. 23(b),

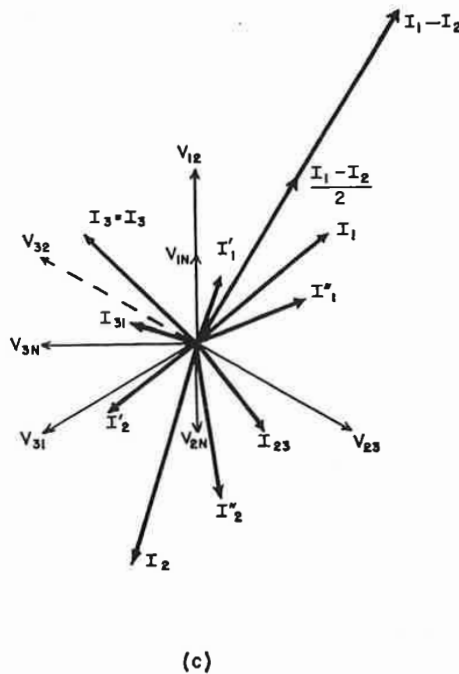
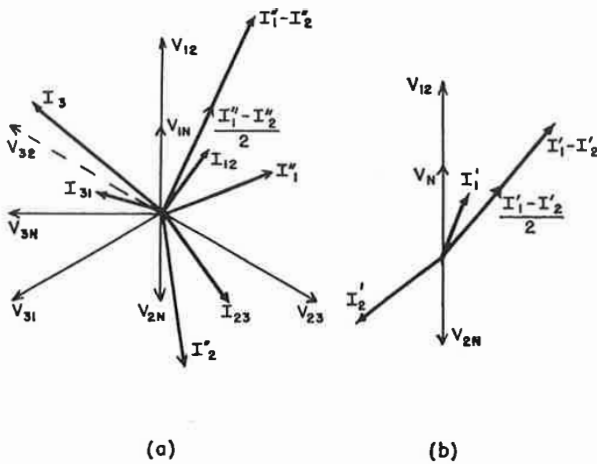

Fig. 23—Vector diagrams for circuit for metering a three-phase, four-wire delta circuit (a) Three-phase load only, (b) Single-phase load only, (c) Combined single- and three-phase loads.

which is the same diagram shown in Fig. 11(b) for the single-phase, three-wire meter. The vector diagram for the combined single-phase and three-phase loads is shown in Fig. 23(a). This is a composite diagram in which Fig. 23 (a) is superimposed on Fig. 23(b). Single-prime I's indicate single-phase currents; double-prime I's indicate three-phase currents; and the unprimed, single subscript I's indicate the combined single-phase and three-phase currents.

This type of load can be metered by either a two-stator meter, a three-stator meter, or the equivalent of either. A two-stator meter has one two-wire, stator and one three-wire stator driving a common shaft. A three-stator meter has three two-wire stators which drive a common shaft. The choice of the type of meter to use in a particular application depends upon the balance of the voltages on the three-wire (lighting) phase.

The analysis of the single-phase, three-wire meter previously made is equally applicable here. The accuracy in metering only the three-phase loads need be considered here.

Let P''_{T3} = power delivered to the three-phase load.

$$P''_{T3} = V_{12}I''_1 + V_{32}I''_3 \tag{a}$$

But

$$V_{32} = V_{3N} + V_{N2}$$
 and

$$V_{12} = V_{1N} + V_{N2}$$

Then (28)

$$P''_{T3} = (V_{1N} + V_{N2})I''_1 + (V_{3N} + V_{N2})I''_3$$

$$= V_{1N}I''_1 + V_{N2}(I''_1 + I''_3) + V_{3N}I''_3$$

But

$$I''_1 + I''_3 = -I''_2 \tag{c}$$

Therefore

$$P''_{T3} = V_{1N}I''_1 - V_{N2}I''_2 + V_{3N}I''_3 \tag{d}$$

If the line-to-neutral voltages are balanced,

$$V_{1N} = V_{N2} = \frac{V_{12}}{2}$$

$$P''_{T3} = \frac{V_{12}}{2}(I''_1 - I''_2) + V_{3N}I''_3 \tag{a}$$

$$= \frac{(V_{1N} + V_{N2})}{2}(I''_1 - I''_2) + V_{3N}I''_3 \tag{b}$$

Let P''_M = three-phase power measured on 2-stator, three-phase, four-wire, delta meter.

P''_{T3} = true power delivered to three-phase load

P''_{M-3} = three-phase power measured on three-wire stator

P''_{M-2} = three-phase power measured on two-wire stator

$P''_{M-3} = -\frac{V_{12}}{2}(I''_1 - I''_2)$, because three-wire stator is composed of two one-half windings of opposing polarities.

$$P''_{M-2} = V_{3N}I''_3$$

Let $P''_o = P''_{T3} - P''_M$ = Error in registration of three-phase power

Then

$$P''_o = \frac{1}{2}(V_{1N} - V_{N2})(I''_1 + I''_2) \tag{30}$$

The error, P''_e , is one-half the dot product of the voltage difference, $(V_{1N} - V_{N2})$ and the current sum, $(I''_1 + I''_2)$ where all quantities, including the difference and sum, are phasors. Reference to Equation 16 shows that the error in measurement of three-phase power is of the same form as the expression for the error in the single-phase, three-wire meter.

The error in the registration of three-phase load expressed in watts, has little meaning itself. The error expressed as percentage of the true value is more significant. It is of interest to consider the phasor $(V_{1N} - V_{N2})$ as being either in phase with or 180° out of phase with V_{12} and in quadrature with V_{2N} , and expressed as a percentage of normal line-to-line and to consider balanced three-phase loads only are considered. Then, in per unit,

$$P''_e = \frac{P''_e}{P_{T3}} \quad (a) \quad (31)$$

$$P''_e = \frac{1}{2} V_u \frac{(-\tan \theta)}{\sqrt{3}} \quad (b)$$

where $V_u = \frac{(V_{1N} - V_{N2})}{V_{12}}$

V_u = the voltage unbalance to neutral in per unit of normal line-to-line voltage.

θ = angle by which phase current lags phase voltage.

The vector diagram for a balanced three-phase load on a three-phase, four-wire delta system is shown in Fig. 24. The variation in error with load power factor can be analyzed with the aid of Fig. 24 and Equation 31. A one per cent unbalance in line-to-neutral voltage results in no error for unity power factor load. As the power factor decreases, $\tan \theta$ increases at an increasing rate. At 50 per cent power factor, a voltage unbalance of one per cent results in an error in registration of one-half of one per cent. As the power factor approaches zero, the phasor $(I''_1 + I''_2)$ approaches in phase with the voltage unbalance. The true power becomes zero and the percentage error in the power registration increases without limit. When the error is objectionable, a three-stator meter is used.

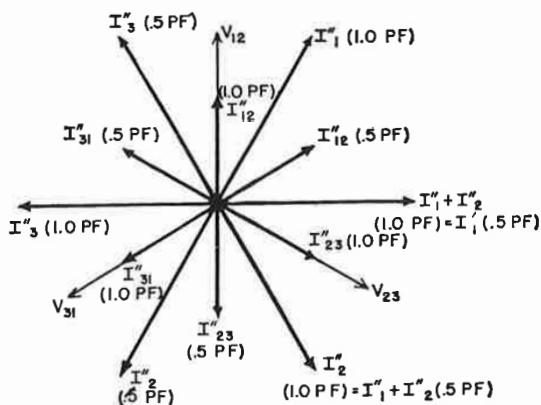

Fig. 24—Vector diagram for balanced three-phase loads at various load power factors for analyzing variation with load power factor of apparent power factor as seen by meter stators.

Two-Phase, Four-Wire—A two-phase, four-wire circuit consists essentially of two single-phase, two-wire systems in which the applied voltages are 90° apart. Such a circuit can, therefore, be metered with a two-stator meter, which is composed of two two-wire stators.

The circuit diagram showing the metering of a two-phase, four-wire circuit with a two-stator meter is shown in Fig. 25(a). The vector diagram is also shown in

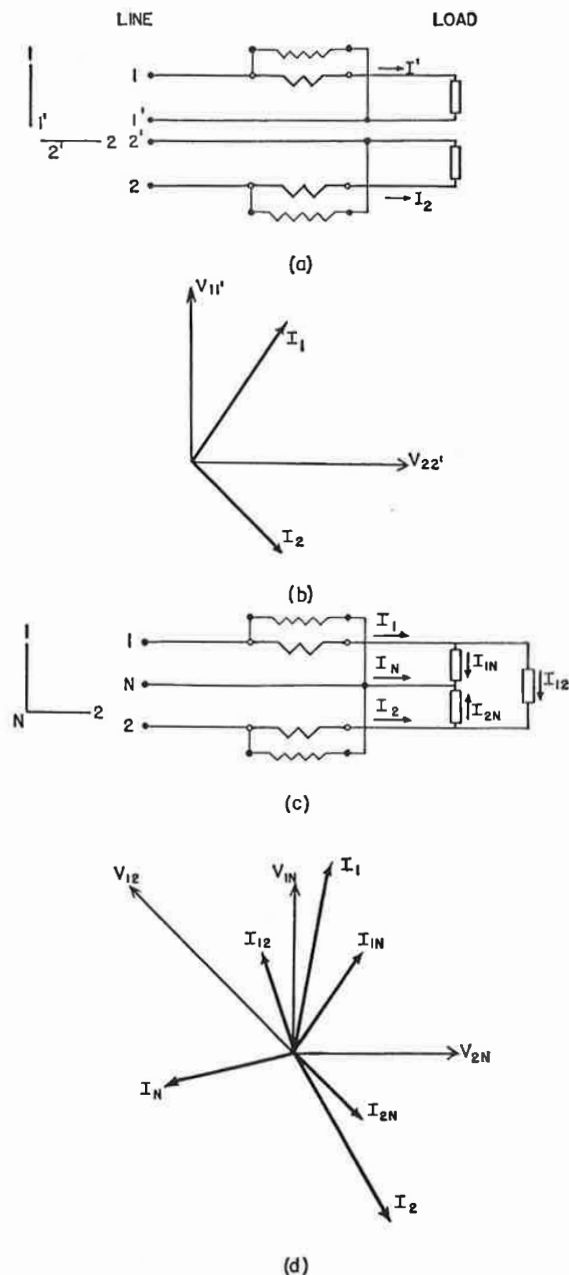

Fig. 25—(a) Diagram of connections for metering a two-phase, four-wire circuit, (b) Vector diagram of (a), (c) Diagram of connections for metering a two-phase, three-wire circuit (b) Vector diagram of (c).

Fig. 25(b). Metering of two-phase, four-wire service is essentially the totalizing of two two-wire services which are fed from separate sources in which the applied voltages are 90 degrees out of phase. The restriction on the circuit shown in Fig. 25(a) for accurate metering is that no load may be connected between the conductors which contain current coils. This restriction can be removed by connecting at both ends the conductors which do not contain current coils. Then it becomes a two-phase, three-wire circuit as shown in Fig. 25(c). The vector diagram for the two-phase three-wire circuit is shown in Fig. 25(d). It is similar to the two-phase three-wire network circuit except that the voltages are 90 degrees, rather than 120 degrees, out of phase.

Analysis of the accuracy of metering a three-phase, three-wire circuit as shown in Fig. 25d is as follows:

$$\begin{aligned}
 \text{(True Power)} \quad P_T &= V_{1N}I_{1N} + V_{2N}I_{2N} + V_{12}I_{12} \quad (a) \quad (32) \\
 P_T &= V_{1N}(I_{1N} + I_{12}) + V_{2N}(I_{2N} - I_{12}) \quad (b) \\
 P_T &= V_{1N}I_1 + V_{2N}I_2 \quad (c) \\
 P_M &= V_{1N}I_1 + V_{2N}I_2; \\
 &\therefore \text{the meter registers correctly} \quad (d)
 \end{aligned}$$

Where P_T = True Power
 P_M = Measured Power

Two-Phase, Five-Wire—A two-phase, five-wire system is essentially two single-phase, three-wire systems in which the line-to-line applied voltages are 90 degrees out of phase and which have a common neutral. Loads on this type of system can be metered with two single-phase, three-wire meters or four single-phase, two-wire meters, or the multi-stator meter equivalents. The diagram of connections for metering two-phase, five-wire loads by means of two single-phase, three-wire meters is shown in Fig. 26.

The dependency of accuracy upon balanced voltages of a three-wire stator in metering a three-wire, single-phase service is also applicable to metering a two-phase, five-wire circuit. Four two-wire stators will give correct registration, independent of the balance of the line-to-neutral voltages. However, usually the voltages are sufficiently balanced that the circuit can be metered with sufficient accuracy by a meter having two three-wire stators.

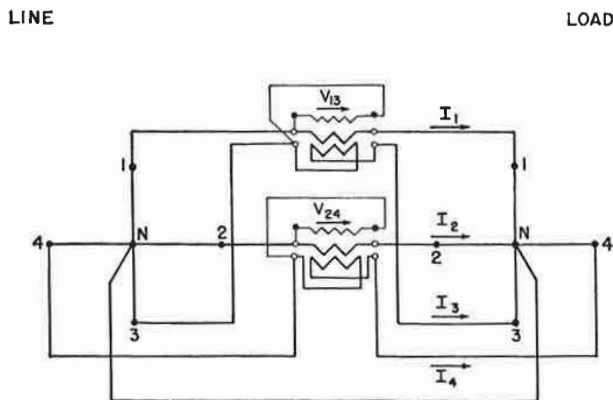

Fig. 26—Diagram of connections for metering a two-phase, five-wire circuit using two three-wire stators.

Also, all of the various methods of applying transformer rated meters to three-wire single-phase services apply equally well to each stator of a two-stator five-wire meter.

Six-Phase, Six-Wire—A six-phase, six-wire system is essentially three three-wire single-phase systems having a common neutral point which is not brought out, and in which the applied voltages to the respective phases are 120 degrees apart. Each single-phase, three-wire load can be metered by a three-wire stator, with the accuracy dependent upon balanced voltages to the same degree as in the single-phase, three-wire circuit. The diagram of connections used for metering such a system is shown in Fig. 27.

Analysis of the accuracy of the circuit shown in Fig. 27 is as follows:

$$\begin{aligned}
 P_T &= V_{1N}I_1 + V_{2N}I_2 + V_{3N}I_3 + V_{4N}I_4 + V_{5N}I_5 + V_{6N}I_6 \quad (33) \\
 \text{If the voltages applied to the respective stators are balanced with respect to neutral,} \\
 V_{1N} = V_{N4} = \frac{V_{14}}{2}; \quad V_{2N} = V_{N5} = \frac{V_{25}}{2}; \quad V_{3N} = V_{N6} = \frac{V_{36}}{2} \\
 P_T &= \frac{V_{14}}{2}(I_1 - I_4) + \frac{V_{25}}{2}(I_2 - I_5) + \frac{V_{36}}{2}(I_3 - I_6) \quad (34)
 \end{aligned}$$

Where P_T = True Power

The three stator, six-wire meter registers this value. The meter connected as shown in Fig. 27, therefore, accurately meters the load, provided the voltages are balanced according to the restriction stated above. Each stator is subject to the same errors due to unbalanced line-to-neutral voltages to which a single-phase, three-wire meter would be subjected under the same unbalance.

The metering is essentially the totalizing of three single-phase, three-wire services in which the applied line-to-line voltages are 120 degrees apart.

Totalizing Metering for Single-Phase and Three-Phase Circuits—The combined energy consumption of a single-phase circuit and of a three-phase circuit can be measured on a totalizing meter. The meter consists of the stators which are normally required for metering the single-phase and three-phase circuits independently; however, the stators drive a common shaft. The meter usually applied to totalize a two-wire, single-phase circuit and a three-phase, three-wire circuit has three two-wire stators. The meter for totalizing energy measurement on a single-phase, three-wire circuit and on a three-phase, three-wire circuit consists of a three-wire

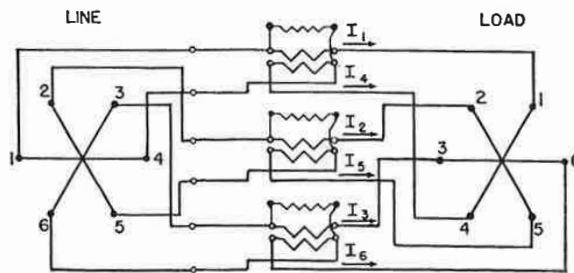

Fig. 27—Diagram of connections for metering a six-phase, six-wire circuit using three three-wire stators.

Table 2 — Watthour Meter Socket Selector Guide

Socket	Wiring Data		Watthour Meter Application*										
	Type □	No. of Jaws	Type of Terminals	Wire size, maxi-mum	amp maxi-mum	1 phase, 2 or 3 wire	1, 2, 3 phase, 3 wire	3 phase, 4 wire Y	3 phase, 4 wire Δ	2 phase, totalizing 5 wire 1-3 phase	Self Contained Transformer Type [†]	Self Contained Transformer Type [†]	Self Contained Transformer Type [†]
Round Sockets	SE	4	set-screw	#1	100	S	S-5
	SE-5	5	set-screw	#1	100	S	S-5
	SE-6	6	set-screw	#1	100	S	S-5
	S	4	bus	#0	100	S	S-5
	S-5	5	bus (4 screw (1))	#0	100	S	S-5
	S-6	6	bus (4 screw (2))	#0	100	S	S-5
Ring Sockets	S	4	bus (line side only)	#0	100	S	S-2	S-20	S-20
	S-2	4	set-screw	#2	100	S-2	S-7	S-7
	S-3	13	set-screw	#2	100	S-5
	S-5	5	bus (line side only)	#0	100	S-5
	S-6	6	bus (line side only)	#2	100	S-5
	S-8	7	set-screw	#2	100
	S-9	14	set-screw	#2	100	S-7, S-9	S-9
	S-10	15	set-screw	#2	100	S-4	S-6
Trough Sockets	ST-2	8	set-screw	#2	100	S-2
	ST-3	13	set-screw	#4/0	140	S-2
	ST-5	5	semi-floating	#2	100	S-5
	ST-8	7	semi-floating	#4/0	140
	ST-9	14	semi-floating	#4/0	140
	ST-10	15	semi-floating	#4/0	140
High-Capacity Sockets	STL-4	4	heavy-duty	#4/0	160	S-5
	STL-5	5	heavy-duty	#4/0	160	S-5
	STG-4	4	heavy-duty	#4/0	200	S-5
	STG-5	5	heavy-duty	#4/0	200	S-5
	STU	4	heavy-duty	#4/0	200	S-5
	STU-5	5	heavy-duty	#4/0	175	S-5
	STU-8	7	heavy-duty	#4/0	175
Transformers													
Sockets			transformers										
	STS	6	200 amp	500 mcm	400	8
	STS-2	5	200 amp	500 mcm	400	S
	STS-3	13	200 amp	500 mcm	400
	STS-7	8	200 amp	500 mcm	400
	STS-8	13	200 amp	500 mcm	400
	STS-9	14	200 amp	500 mcm	400
Trans-A-Mount Mountings	STA	2	200 amp	500 mcm	400	A
	STA-2	3	200 amp	500 mcm	400
	STA-3	2	200 amp	500 mcm	400
	STA-7	1	200 amp	500 mcm	400
	STA-8	3	200 amp	500 mcm	400
	STA-9	3	200 amp	500 mcm	400

Demand Meter Application
Westinghouse socket-type demand meters (series DS, DSH, QDS, etc.) employ the same sockets as their corresponding watthour meter types.
Westinghouse bottom-connected thermal demand meters (series CAH, KCA, QCA, etc.) require special styles of Trans-A-mount mountings: Indicating demand meters (series CA-W) employ the same Trans-A-mount as their equivalent series DA meters.

Notes
□ Westinghouse designation.
★ For further application information including wiring diagrams, see Fig. 28, 29, 30, and 31.
♣ Maximum current rating based on 55°C temperature rise above a maximum ambient of 35°C in current coil of meter listed when socket is wired with maximum-size conductors.
■ All sockets used with instrument transformers must have circuit-closing devices.
* STS (5 terminal, STS-7 and STA-7: 400-amp current transformers have secondaries connected in parallel to serve as one 200 5-3-wire current transformer.
† STS-8 (for S-2): current transformer secondaries are connected in delta.
‡ S-2 transformer-type for 3-phase, 4-wire Y; current transformer secondaries must be connected in delta.
○ S-2 transformer-type for 3-phase, 4-wire Δ; use with one 2-wire and one 3-wire current transformers.
♠ S-2 for 2-phase, 5-wire service: use transformer type only with two 3-wire current transformers.

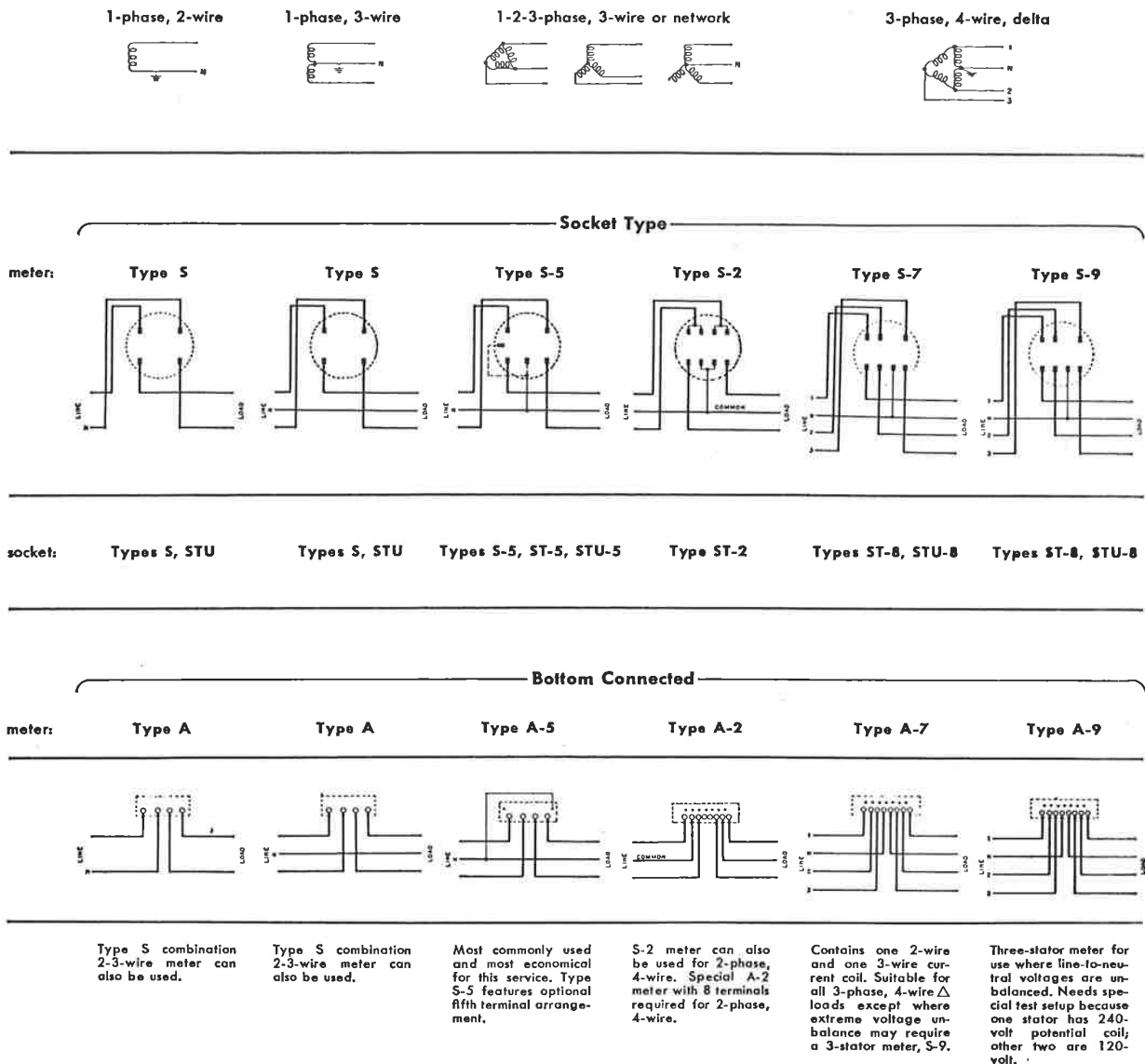

Fig. 28—Circuit Connections for self-contained socket (detachable) type and bottom connected meters.

Continued on next page

stator applied to the single-phase circuit and two two-wire stators applied to the three-phase circuit. The accuracy is the same as would be obtained by using separate meters in the single-phase and three-phase circuits.

The energy to the three-phase circuits is metered correctly. However, the accuracy of the metering in the single-phase three-wire circuit is dependent upon the balance of the line-to-neutral voltages in that circuit. The voltage rating of each stator corresponds with voltage at the circuit which it is applied.

Summarizing Watthour Meter Applications—The application of watthour meters to the various types of circuits is summarized in Figs. 28 and 29. The circuit con-

nections for self-contained meters in socket type and bottom connected are shown in Fig. 28. Corresponding circuit connections for transformer rated meters are shown in Fig. 29.

The internal wiring diagrams for socket-type and bottom-connected self-contained and transformer-rated meters are shown in Fig. 30.

12. Installation of Watthour Meters

The specifications for the location and other watthour meter installation requirements are established by the utility or other owner of the meter. However, the safety code provides that certain safety measures be taken in

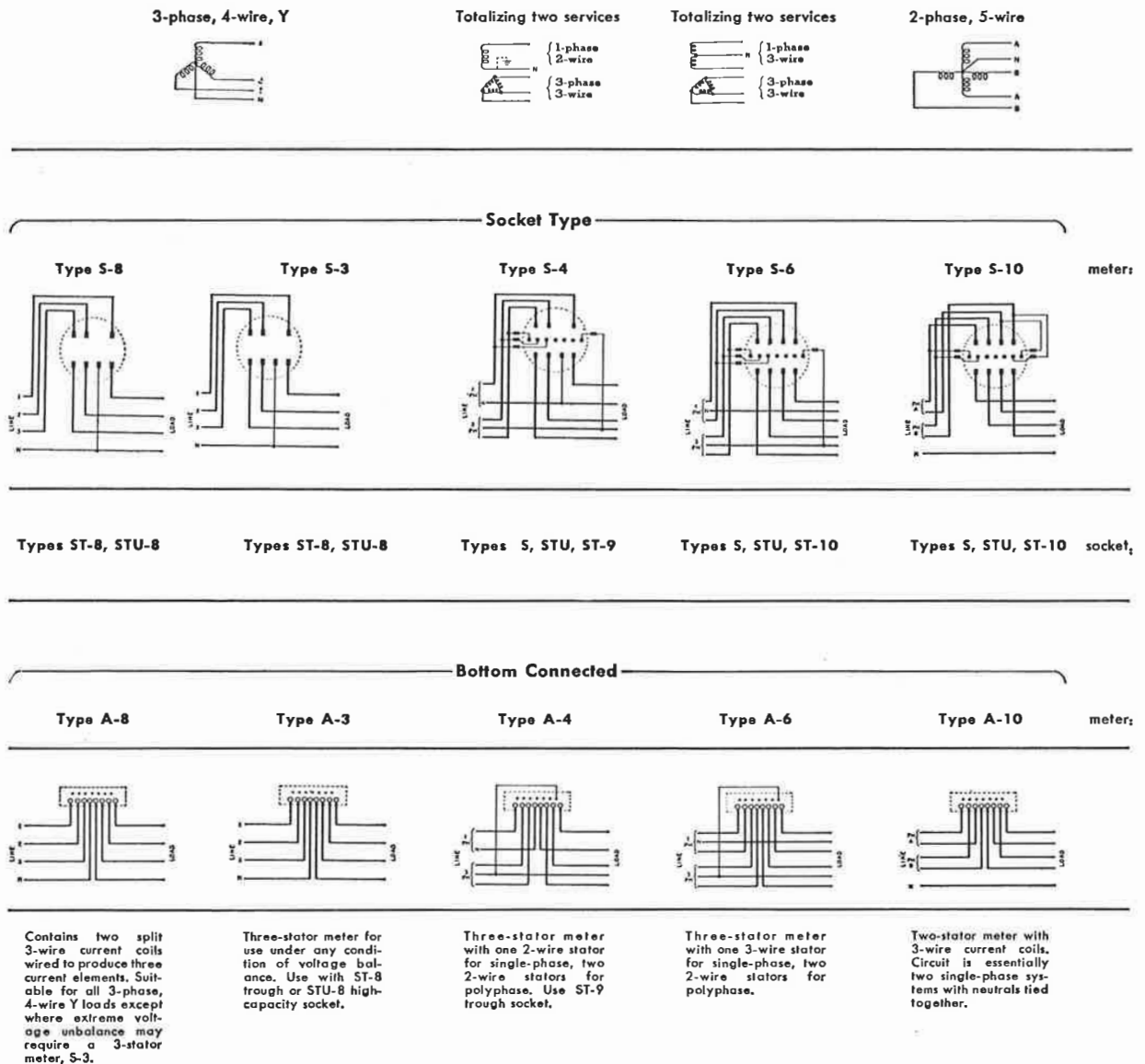

Fig. 28—continued

the installation of circuits to the meter.

Socket and mountings with built-in current transformers for detachable and bottom-connected meters are also available. Westinghouse sockets with current transformers are designated as Transockets. Corresponding mountings for bottom-connected meters are designated as Trans-A-Mounts.

Various available sockets, Transockets or Trans-A-Mounts for application with the various detachable and transformer-rated, bottom-connected meters are given in Table 2.

The terminals arrangement in detachable (socket-type) and bottom-connected watt-hour meters have

been standardized. The standard terminal arrangements for these types of meters are shown in Fig. 31. For the terminal arrangement in switchboard meters, reference is made to the manufacturer's literature as may be required.

13. Metering Reactive Voltampere-Hours ^{13, 19, 20, 21}

Metering of reactive voltampere-hours is of particular importance to the utility where the rate schedule contains a power factor clause which provides the manner in which load power factor influences the charges for electric service. The manner in which load power factor is included in the rate schedule varies with utilities, but

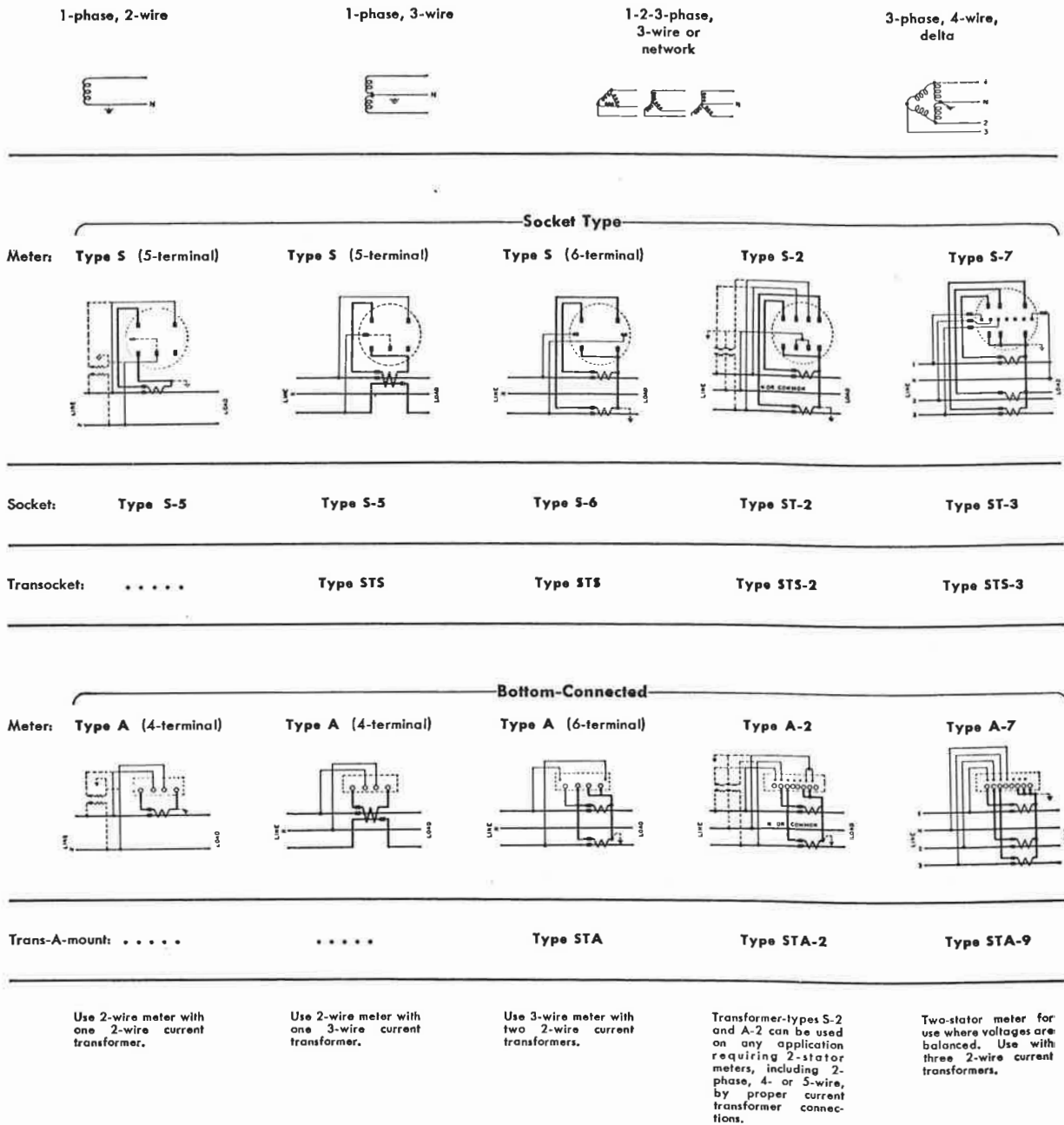

Fig. 29—Circuit connections for transformer-rated meters.

Continued on next page

it generally affects a measurement of quantities necessary for determining the charge. In some rate schedules, the power factor clause is based upon the average monthly power factor. Another manner provides for a reactive voltampere demand charge. Usually, the power

factor clause applies to the larger industrial or power customers. The metering of services to such customers includes both energy (watthour) meters and reactive power (varhour) meters.

The reactive power metering is usually done by a

3-phase, 4-wire, delta

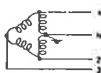

3-phase, 4-wire, Y

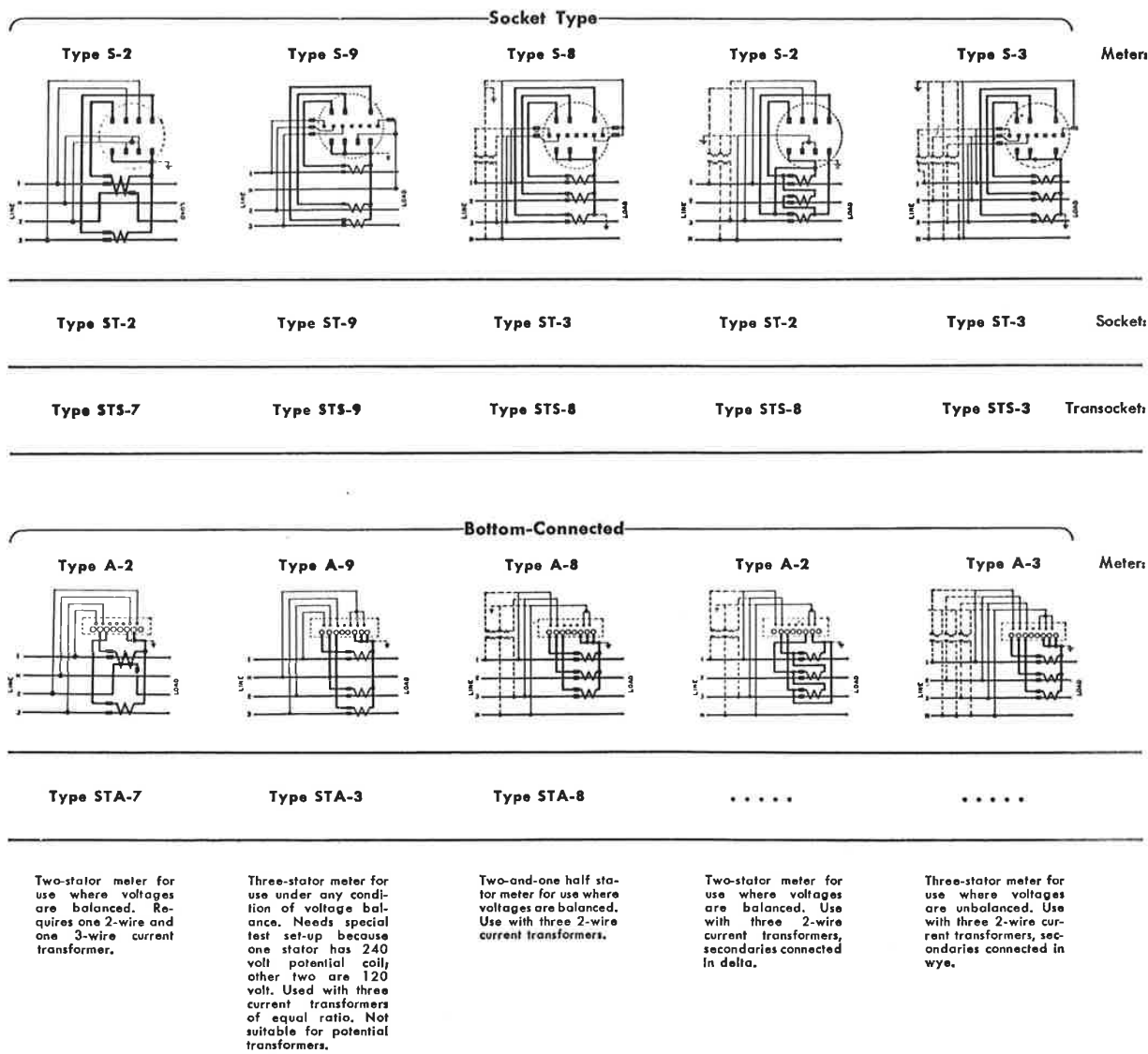
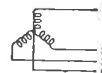
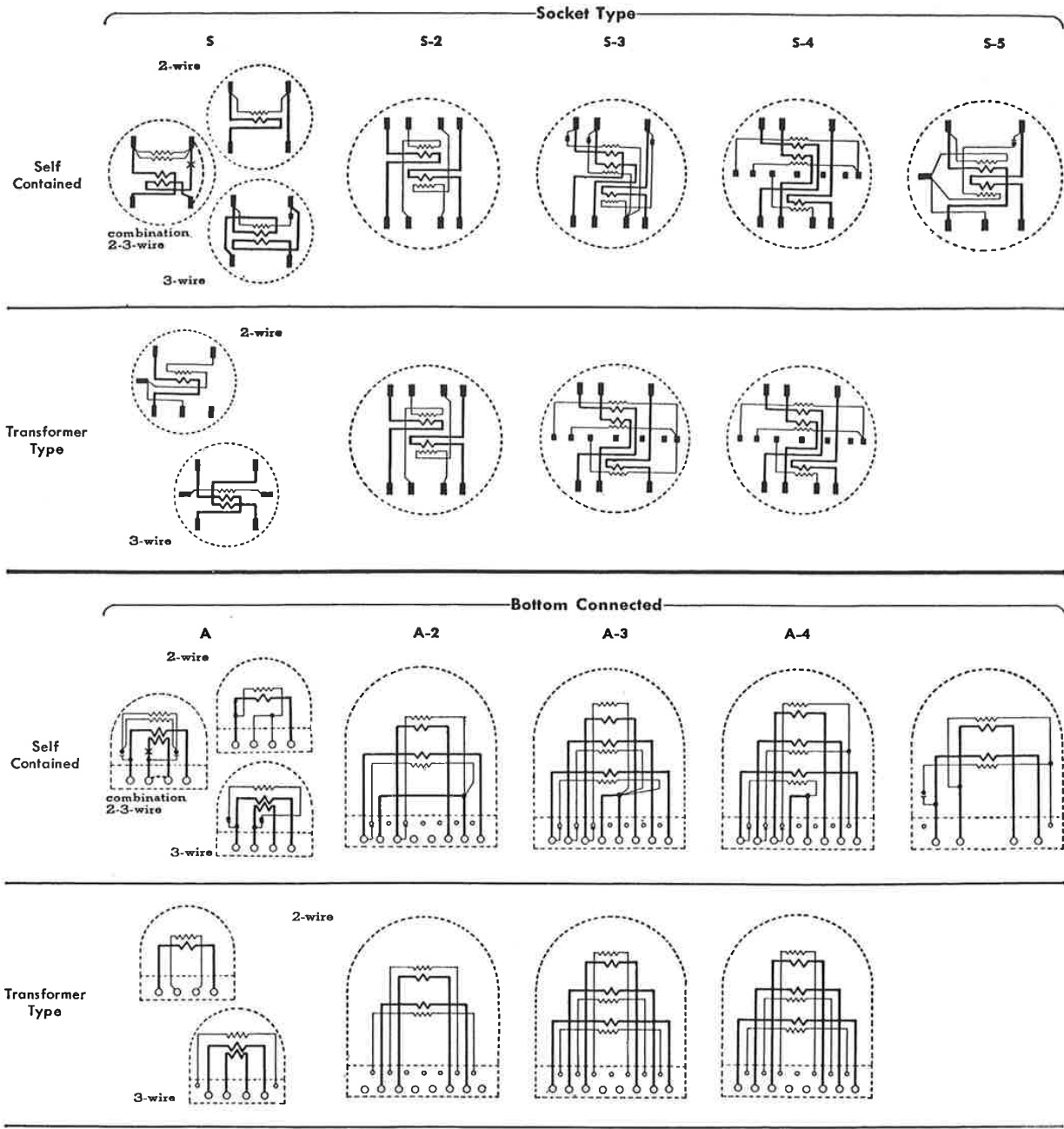

Fig. 29—continued

watthour meter to which a voltage which is equal to and lagging quadrature with the system voltage is applied to the potential circuits. The speed of the rotating disk of such a meter is proportional to reactive power in the positive direction. The registration of the meter in a

specific time interval is proportional to the average reactive power during that interval. A demand register on such a meter indicates the maximum reactive demand during the period such as the billing period. Similarly, the registration of a watthour meter in a specific



Notes ▶

Standard single-phase meter. Combination 2-3-wire self-contained meters come wired for 2-wire, 120 volt, with potential coils in parallel and one current coil disconnected and bridged. Self-contained 6-terminal A (not shown) is like transformer type.

Standard 2-stator meter. S-2 self-contained and transformer-type and A-2 transformer-type can be used as wired on 1, 2, or 3-phase service. A-2 self-contained must be ordered with 8 terminals for 2-phase, 4-wire.

Standard 3-stator meter. S-3 self-contained and transformer-type and A-3 self-contained have one side of each potential coil tied together. A-3 transformer-type has all potential leads brought out separately.

Three-stator meter for totalizing 3-phase, 3-wire and 1-phase, 2-wire from separate sources. Two stators for polyphase load have one side of each potential coil tied together except on A-4 transformer type. Third stator for single-phase is separate.

Standard 2-stator 3-wire network meter. Internally similar to S-2 and A-2 meters. Terminal-arrangements similar to single-phase S and A.

Fig. 30—Internal wiring diagrams for socket-type and bottom connected and transformer-rated meters.

Continued on next page

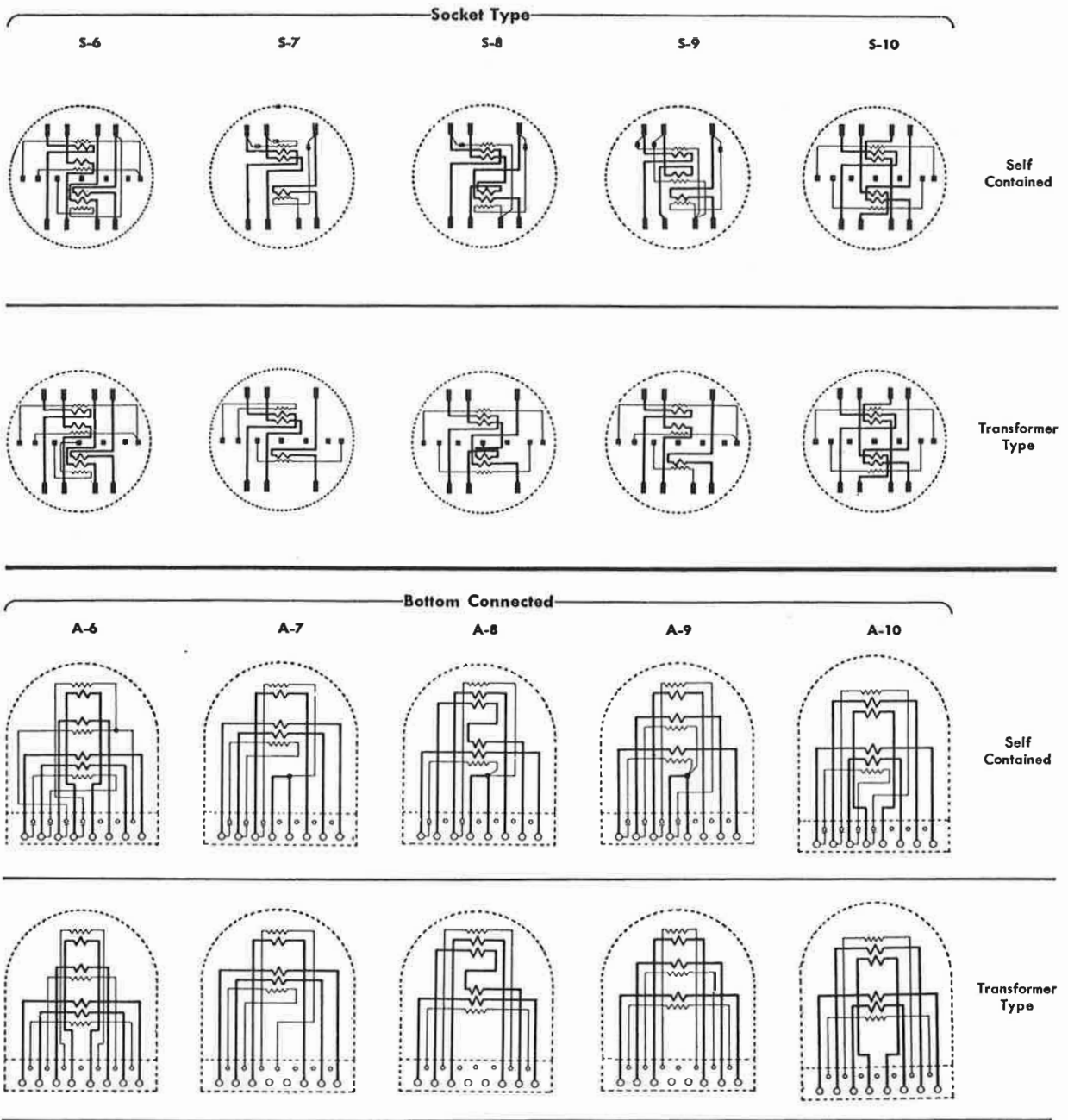

Three-stator meter for totalizing 3-phase, 3-wire and 1-phase, 3-wire from separate sources. Similar to S-4 and A-4 except single-phase element has 3-wire electromagnet. Slightly different terminal arrangements from S-4 or A-4.

Two-stator meter for 3-phase, 4-wire, delta service. One stator has 2-wire, 240-volt electromagnet, other has 3-wire, 240-volt electromagnet.

Two and one-half stator meter for 3-phase, 4-wire Y service. Meter has two stator with 3-wire current coils. One half of each current coil is tied together to form in effect a third current stator.

Three-stator meter for 3-phase, 4-wire delta service. Two stators have 120-volt potential coils; third stator has 240-volt potential coil. Current windings of 120-volt coils have twice current rating of 240-volt coil to make watt ratings of stators equal.

Two-stator meter for 2-phase, 5-wire service. Each electromagnet has 3-wire current winding.

Sockets

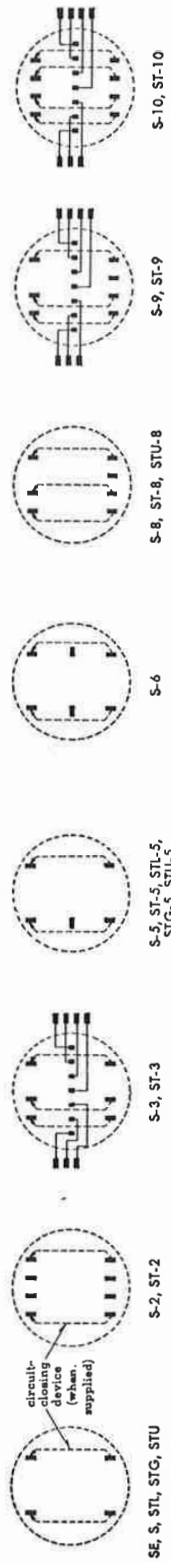

Transocket Sockets

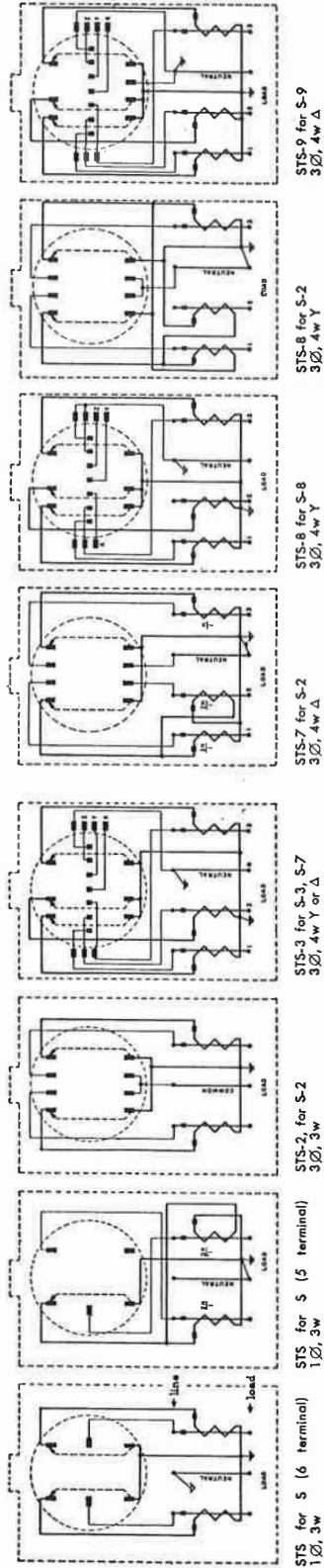

Trans-A-mount Mountings

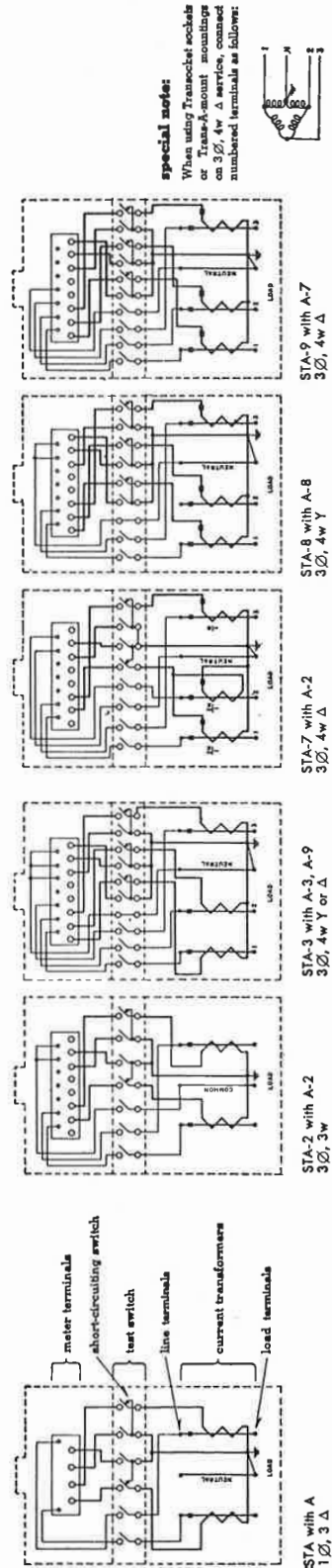

Fig. 31—Terminal arrangement of sockets and mounts for transformer-rated meters.

For external wiring diagrams, see Fig. 29

interval is proportional to the average active power during that interval. Therefore, the average load power factor for the period can be determined from the reactive kilovoltampere-hour and kilowatthour registrations for the period. The average power factor is given by

$$(F_p)_{avg} = \cos \left(\tan^{-1} \frac{\text{varhours}}{\text{watthours}} \right)$$

For correct registration of the varhours, the voltage applied to the potential circuit must be equal in absolute value to the voltage applied to the watthour meter, and in lagging quadrature with that voltage. The circuit voltage is shifted by 90 degrees in the lagging direction before it is applied to the varhour meter. The corresponding current coils of the watthour and varhour meters are connected in series. The manner in which the voltage is shifted for reactive metering is dependent upon the type of system. This discussion is restricted to methods of obtaining the required phase shift and the equipment available.

Two-Phase Systems—Reactive metering in a two-phase system is simpler than it is in either the single-phase or three-phase systems. Since the phase voltages are displaced by 90 degrees, no phase shifting equipment is required. The watthour and varhour meters in a two-phase service are connected as shown in Fig. 32. This is referred as cross-phasing. The accuracy of the reactive meter is dependent upon the phase voltages being equal and 90 degrees out of phase.

Three-Phase Systems—Shifting of system voltage for reactive metering in a three-phase system is done in phase-shifting transformers. They consist of small auto-transformers with taps so arranged that voltages equal to and lagging the line voltage by 90 degrees are obtainable. In order for phase-shifting transformers to be applicable, it is necessary that the meter potential terminals be independent of the current terminals.

The various types of Westinghouse phase-shifting transformers available and the system application and voltage rating of each are shown in Table 3. The accuracy of the transformers may be checked by applying rated voltages from a system of balanced voltages to the transformers and measuring voltage between various tops as shown in Table 4.

The internal wiring diagrams of the various types of transformers and the taps from which quadrature voltages are obtained are shown in Fig. 33. The phase shifts shown result if the applied voltages are from a system of balanced voltages of the sequence 1-2-3. Unbalances in system voltages result in errors in the phase shift.

External and internal wiring diagrams of a Type K-5 transformer for application to various types of systems are shown in Fig. 34. The connections to potential circuits only of the watthour and varhour meters are shown. The corresponding meter current elements are connected in series.

Single-Phase Systems—The 90-degree phase shift necessary for reactive metering on single-phase services is obtained by connecting a resistor capacitor series network in series with the potential circuit of the watthour (varhour) meter with which it is applied. The resistor is

variable, since the network must be calibrated individually for the meter with which it is to be used. The Westinghouse Type K-1 compensator is a resistor capacitor network for obtaining the 90-degree phase shift required for single-phase reactive metering.

V. DEMAND METERING

The demand of an installation or system is the load at the receiving terminals averaged over a specified interval of time. Demand is expressed in suitable units of the load commodity. The load may be real power, reactive power, apparent power, or current, and may be expressed in kilowatts, reactive voltamperes, voltamperes, or amperes, respectively. The most common demand intervals used in commercial metering are 15 minutes and 30 minutes, although other intervals such as 5 minutes or 60 minutes have been used in some cases.

Similarly, the maximum demand of an installation is the greatest of all demands which have occurred during a given period of time. The period of time during which the maximum demand is usually desired is the month or the billing period. Of course, the maximum demands for longer periods, such as a year, can be determined from the maximum demands of each of a group of periods, such as a month, which make up the longer period. The maximum demand is determined by measurement, according to specifications, over a definitely prescribed time interval.

14. Types and Classes of Demand Meters

Classes—Demand meters may be classified according to the manner in which demand is measured and according to the presentation of the measurements such as:^{8,22}

Class I —curve-drawing or recording demand meters

Class II —integrated- or block interval-demand meters

Class III—lagged-demand meters

Recording Demand Meter—The designation of Class I indicates only the manner of presentation of the measurement and does not indicate the manner of the measurement, i.e., integrated or lagged demand. In the recording meter, a permanent record is made of the demands measured during the period of the record. The demands may be recorded on a paper strip chart, on printed or punched paper tape, or on magnetic tape. Usually, a recording demand meter is considered as a demand meter which uses a strip chart and in which the stylus is advanced across the paper chart at a rate proportional to the watthour. The chart is driven continuously by a clock mechanism. A meter in which the measurement is printed on a tape is usually referred to as a printometer. Magnetic or punched tape recorders are relatively recent developments in which the measured demand is recorded on magnetic or punched tape, from which the data are extracted by auxiliary devices for correlation on data processing machines.

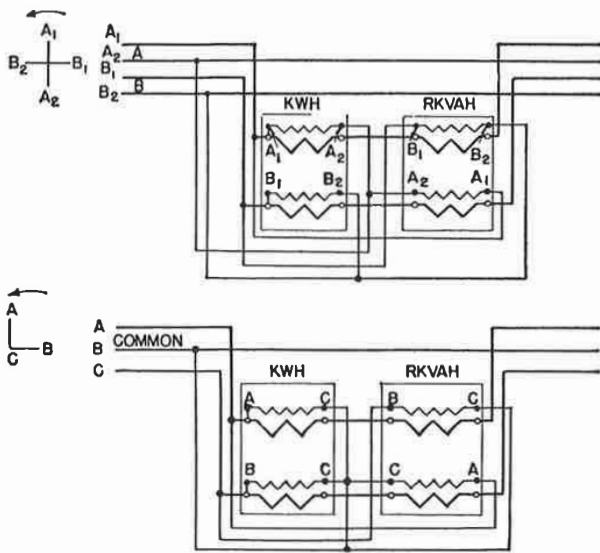

Fig. 32—Diagram of connections for reactive metering on two-phase systems.

Indicating Demand Meter—An indicating demand meter or register is a demand meter which is equipped with a scale over which a friction pointer is advanced to indicate maximum-demand. The indicating demand meters may be of the integrated demand (Class II) or of the lagged demand (Class III).

Cumulative Demand Meter—A cumulative demand meter or register is an indicating demand meter in which the accumulated total of maximum demands during the preceding periods is indicated during the period after the meter has been reset and before it is reset again. The maximum demand for any one period is equal to or proportional to the difference between the accumulated readings before and after reset. The accumulated maximum demands are presented on a group of dials and pointers similar to those on the watt-hour meter. The cumulative demand meter or register is of the integrated-demand (Class II) type.

Table 3—Application Chart for Westinghouse Phase-Shift Compensators

Service	Meter—No. of Elements	Phase Shifting Transformer
3-phase, 3-wire	2	K-3
	2	K-5
3-wire network	2	K-5
3-phase, 4-wire, delta	2	K-7
	2	K-5
3-phase, 4-wire, wye	3	K-9
	3	K-5
	2½	K-4
	3	K-5
	3	K-4 K-5

Table 4—Tests for Ascertaining the Accuracy of Phase-Shift Compensators, of Table 3
120 Volt* Phase-Shifting Transformers

	Apply 100 Volts to Terminal	57.7 Volts should be voltage across	115.5 Volts should be voltage across
Type K-3	1-2 3-2	4-2 7-2	6-2 5-2
Type K-4	1-0 2-0 3-0	6-0 4-0 5-0
Type K-5	1-2 ... 3-2 ...	4-2 8-2 7-2 9-2	6-2 ... 5-2 ...
Type K-7	1-4 3-6	1-2 5-6
Type K-9	1-6 3-0	... 4-0	1-2 5-0

*For 240-Volt transformers double the given voltage values.

Integrated-Demand Meter (Block Interval Demand Meter)—An integrated demand meter is one which indicates or records the demand obtained through integration. The integration is performed over specific demand interval periods. That is, the period during which demands at specific intervals are measured is blocked into discrete periods, the duration of each of which is the prescribed demand interval.

Lagged-Demand Meter (Exponential or Logarithmic Demand Meter)—A lagged-demand meter is one in which the response of the meter element is subject to a characteristic time lag by either mechanical or thermal means. The presentation on such a meter is sometimes referred to as an exponential or logarithmic demand, since the response of the meter as a function of time is an exponential function of the quantity being measured. Usually the lagged-demand meter has a pointer pusher and a maximum-demand pointer which indicates the maximum deflection of the pointer pusher. The pointer pusher indicates the demand over the previous demand interval. Lagged-demand meters are equivalent in their action to an ordinary indicating wattmeter, in which the damping is highly accentuated, resulting in a time lag.

15. Theory and Application of Demand Meters

Integrated-Demand Meters—The integrated-demand principle is applied on both the indicating and cumulative-demand meters. The principle difference in the meters is in the presentation of the data. In fact, both meters are usually watt-hour meters with special registers for measuring both maximum demand and energy consumption. Integrating demand registers are shown in Fig. 35. The indicating demand register has two hands. One hand, the pointer pusher, moves at a rate proportional to the energy consumption; therefore, its total movement in a given interval is proportional to

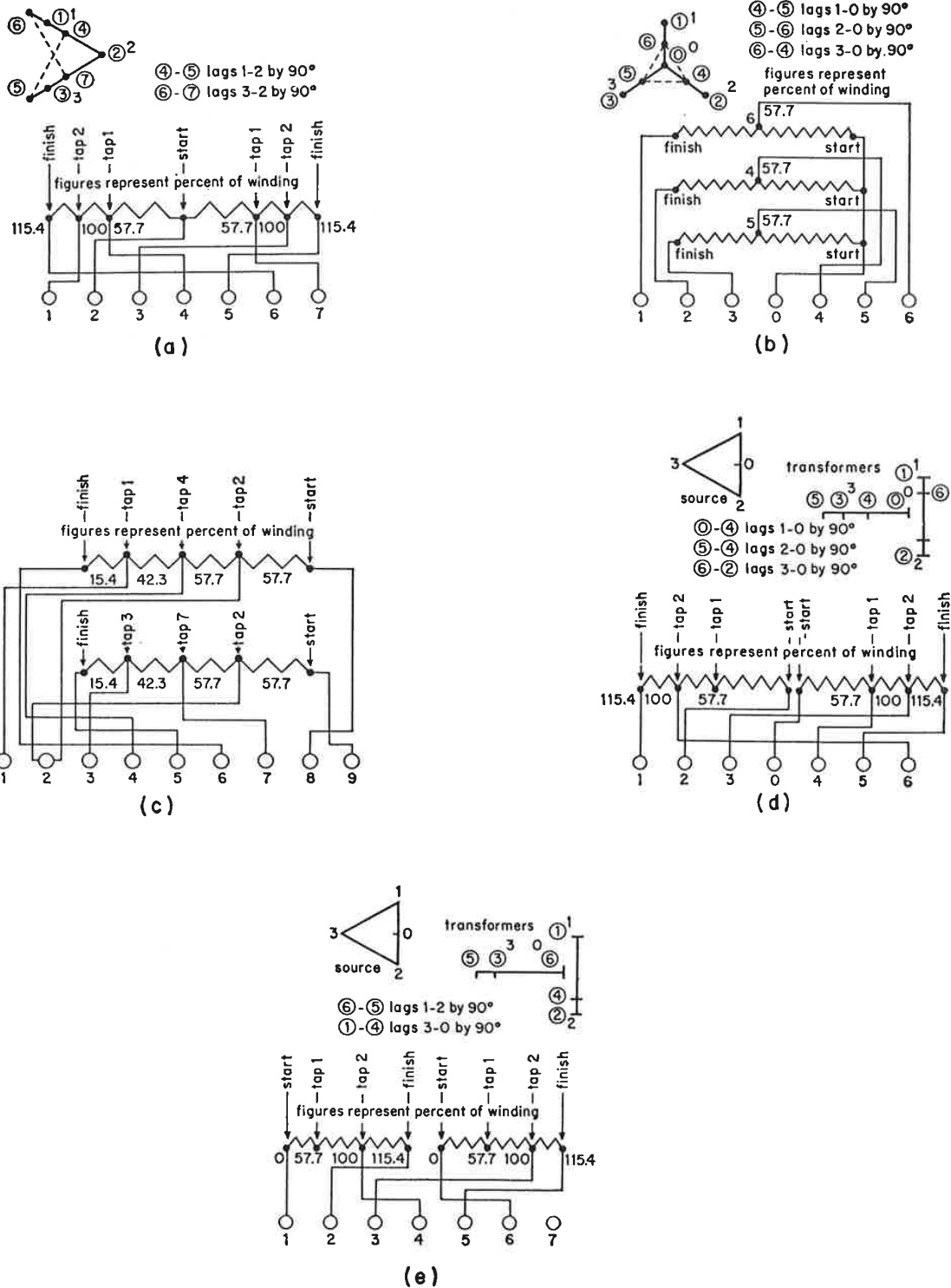

Fig. 33—Internal wiring diagrams of various types of phase-displacement transformers for reactive metering on three-phase systems showing taps from which quadrature voltages are obtained. (a) Type K-3, (b) Type K-4, (c) Type K-5, (d) Type K-7, (e) Type K-9.

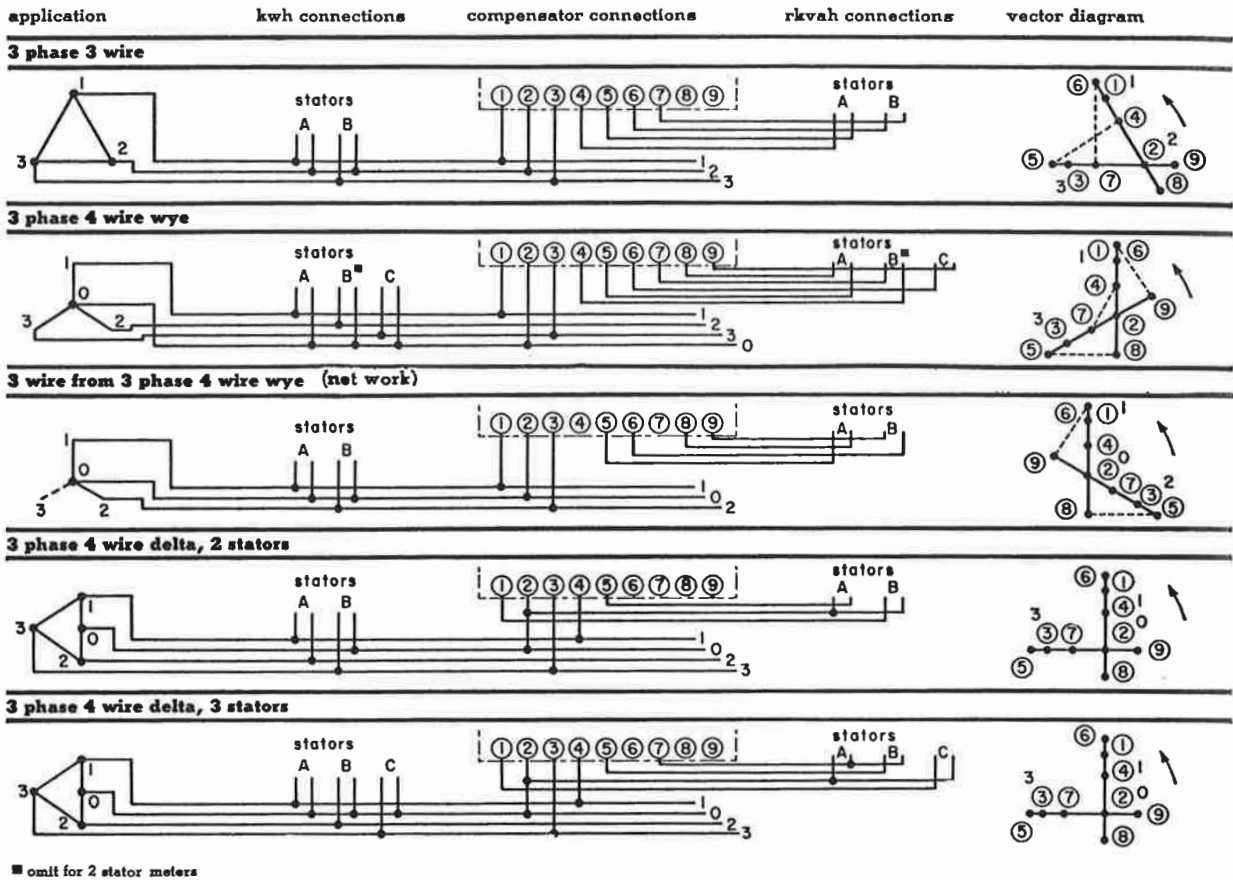

Fig. 34—External and internal wiring diagrams for application of a type K-5 phase displacement transformer for reactive metering on various types of systems.

the demand occurring in that interval. It resets to zero at the end of each interval. The second hand, the maximum demand pointer, is moved by the pointer pusher, and indicates the maximum demand which has occurred since the last resetting of the friction pointer to zero.

In the cumulative-demand register, the registration is on a set of dials similar to those on the watt-hour meter register. The maximum which has occurred since the last resetting of the register is stored within the register. A test dial indicates the approximate maximum demand since the last reset. When the meter is reset, the demand register dials change setting by the value of the maximum demand stored within the register, and the test dial resets to zero. The maximum demand is the difference in the readings of the demand register before and after resetting. The cumulative-demand register can be read to more significant figures than can be read on the indicating demand register. Being a more expensive register, cumulative-demand register is applied on larger loads where the added accuracy can be justified.

Lagged Demand Meter or Register (Thermal Demand)^{23, 24, 26}—In an indicating lagged-demand meter, the demand

indicated by the pointer pusher is the demand over the interval just preceding the time at which it is read. The friction pointer then indicates the maximum demand over any interval of a specific duration in the period, rather than over discrete block intervals. Due to this factor, peak splitting is not possible with the lagged demand meter.

Although the demand interval in an integrated demand meter is the period over which the load is integrated to determine the demand or average load during the interval, the demand interval of a thermally lagged meter is not so clearly defined. The demand interval of a thermal demand meter is considered as the time required for a meter to indicate 90 per cent of the full value of a constant load suddenly applied. This definition has been selected, because it provides an indication which is in close agreement with that obtained by an integrated demand meter with an equal demand interval. The interval of most thermal demand meters is 15 or 30 minutes.

The indication vs. time characteristic of a thermally lagged demand meter which has a demand interval of fifteen minutes is shown in Fig. 36. The characteristic

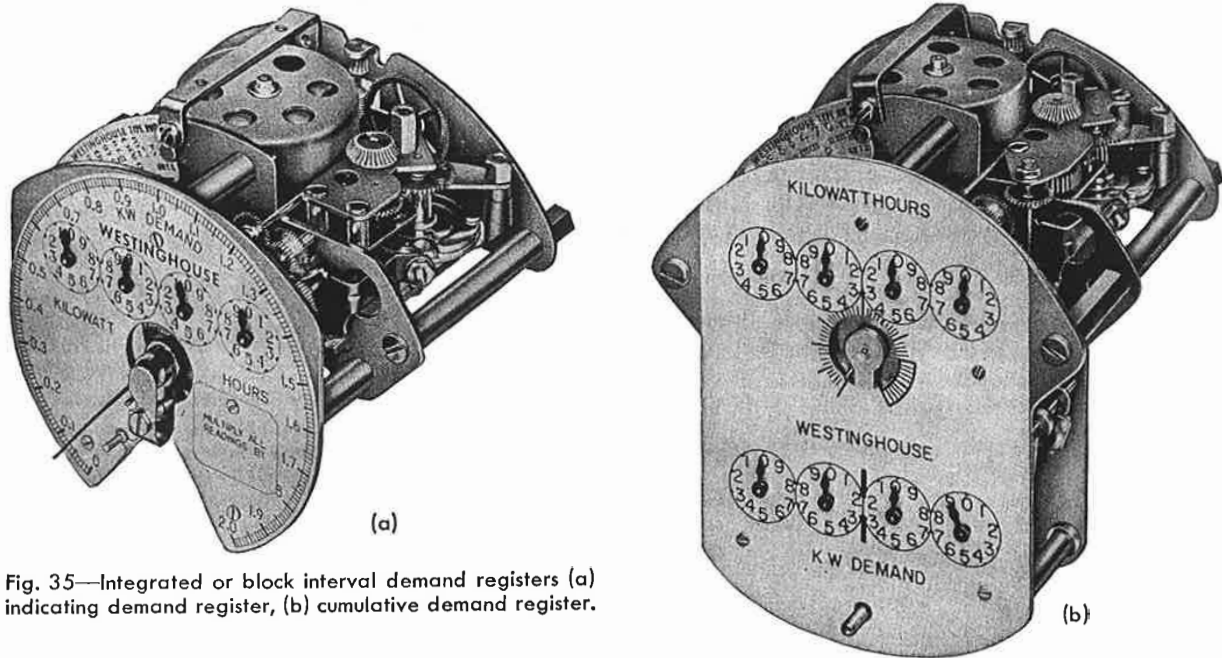

Fig. 35—Integrated or block interval demand registers (a) indicating demand register, (b) cumulative demand register.

shown is the response of the meter when a constant load is suddenly applied. The equation response vs. time characteristic has the form

$$d = D (1 - e^{-kt}) \tag{63}$$

where

d = deflection at any time after applying the load from a previous no-load state.

D = maximum deflection of the meter

$1/k$ = the time-constant of the meter; the time required for the meter to reach its final value if it continues to increase at the initial rate; it is also the time for the deflection to reach 63 per cent of its final value.

t = time after suddenly applying load

Either of two principles may be used to damp or lag a meter. These are thermal and mechanical. Only the principle of thermally lagging meters is applied to an appreciable extent in modern lagged-demand meters; therefore, only thermally lagged-demand meters are considered here.

The thermal element is essentially a thermal storage wattmeter which has a thermal (deflection vs. time)

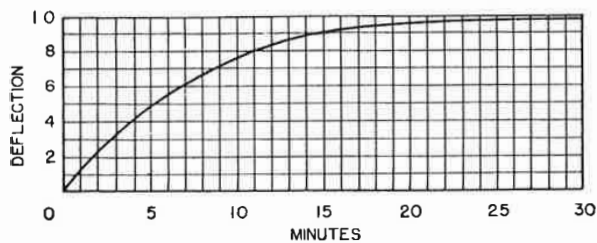

Fig. 36—Response characteristic of thermal demand meter.

characteristic similar to the exponential or heating curve of electrical equipment. However, the characteristic of the meter may not correspond precisely with those of the electrical equipment, due to the variations of the thermal time constants of different types of equipment. The thermal time constants of a thermal-demand meter having a 15-minute interval approximates the thermal time constant of copper conductors, if there is no appreciable dissipation of heat to the environment of the conductor. For example, a fifteen minute thermal demand meter indicates 63 per cent of its final value in 6.5 minutes after a constant load is suddenly applied, while the copper gradient in an oil-filled distribution transformer will reach its final value in from 5 to 8 minutes if there is no heat dissipation to surrounding oil. However, due to heat absorption of heat by the oil, the time is greater, since the top oil temperature will reach its final value in from 3.5 to 5.5 hours if there is no heat dissipation to surrounding air. The rate of heat absorption by the oil diminishes with time. Therefore, the characteristic of a thermal-demand meter approaches the characteristic of a conductor, but it deviates considerably from the characteristic of an oil-filled transformer.

Thermal Kilowatt Demand Meter—The diagram of the basic circuit of a single-phase, thermal kilowatt demand meter is shown in Fig. 37. The bimetal springs, which are wound in opposite directions, are connected to the shaft which carries the pusher pointer. The torque developed in each bi-metal spring is proportional to the temperature rise above ambient in the spring. The net torque to the shaft is proportional to the differential temperature rise of the two springs. The bi-metal springs may be either directly heated by an electric current passing through the spring or indirectly heated

by resistors with an electric current. The indirectly heated design is considered here.

The heater units are connected in series across a potential transformer; therefore, a current I_E , proportional to line voltage, circulates through the heater units in the positive direction shown. Also, a current proportional to load current passes through each heater unit. The positive direction of load current is opposite directions in the heater units. The net current in heater

A is $(I_E + \frac{I}{2})$. The components of currents in each

heater are phasor values. Since power applied to the respective heater units is proportional to the square of the current in each, the power dissipated in the heaters is given by

$$\text{For Heater A } I_E^2 P_a = \left[I_E^2 + I_E I + \left(\frac{I}{2}\right)^2 \right] R \quad (a)$$

$$\text{For Heater B } I_E^2 P_b = \left[I_E^2 - I_E I + \left(\frac{I}{2}\right)^2 \right] R \quad (b)$$

The net torque, T_N , to the shaft is proportional to the difference in power applied to the respective heater units and is given by

$$T_N = C_1(P_a - P_b) = C_2(EI) \quad (a)$$

where C_1 and C_2 are constants and

$$C_2 EI \equiv C_2 |E| |I| \cos \theta \quad (b)$$

Therefore, the net torque developed is proportional to the kilowatts delivered to the load being metered.

The polyphase thermal kilowatt demand meters are similar in operation to the single-phase meter, except for the number of elements used. Two heaters and one potential transformer comprise each element. The bi-metal coil springs of the elements are ganged to one shaft to indicate the total kilowatt demands of the polyphase circuit. Separate potential and current transformers are used for the thermal units in polyphase meters.

Thermal Ampere Demand Meters²⁶—The thermal ampere demand meter is similar to the kilowatt demand meters, except that it contains only the current bi-metal coil spring. Although the ampere demand meter is operated by current only, it is usually calibrated in kva. The calibration assumes constant voltage at the meter.

A phase-shifting network is applied in polyphase ampere demand meters in order to develop heating in one heater unit which is proportional to the total demand of polyphase circuit. The circuit diagram of a three-phase three-wire ampere-demand meter is shown in Fig. 38(a.) The vector diagram is shown in Fig. 38(b.) The polyphase thermal ampere-demand is dependent upon balanced system voltage for correct indication, but it is not dependent upon balanced currents.

Thermal KVA-Demand Meter^{26, 27}—The thermal kva-demand meter which is available only in a polyphase meter is essentially a voltage compensated ampere-demand meter. A second heater unit and bi-metal coil spring is added to correct the indication for a variation in system voltage. The basic arrangement of such a meter is shown in Fig. 39. The potential bi-metal spring is coupled through a linkage to the complete current bi-

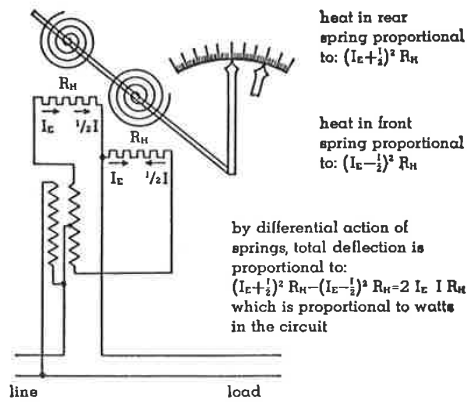

Fig. 37—Diagram of basic circuit of thermal kw demand meter.

metal assembly to cause recalibration at the meter for changes in applied voltage. The thermal kva demand meter is also dependent upon balanced voltages for current indication. Due to the added expense of the kva demand meter over the ampere demand meter, it is applied only when abnormal variations in voltage levels justify a more accurate and more expensive meter.

Combination Thermal Demand-Watthour Meters—Combination thermal demand and watthour meters are available in which the thermal demand meter and a standard induction watthour meter are assembled as a unit. Internal current transformers are used in all meters. The current transformers may supply the watthour meters electromagnet as well as the thermal elements. For single-phase kilowatt demand meters, the watthour meter electromagnet potential coil also serves as the primary of the potential transformers. Separate current and potential transformers are used for the thermal elements of polyphase thermal demand meters.

A considerable variation in price prevails between the corresponding types of combination thermal-demand-watthour meters. The combination thermal kw demand watthour and thermal ampere-demand-watthour me-

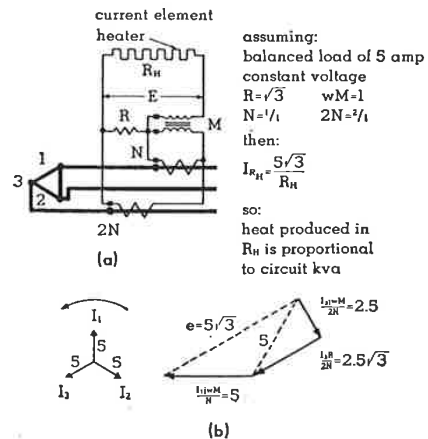

Fig. 38—Thermal ampere-demand meter, (a) Basic circuit, (b) Vector diagram.

ters are comparable in price. However, the cost of the thermal kva-demand-watthour meter is about twice the cost of corresponding thermal kw or ampere-demand-watthour meters.

The combination thermal demand-watthour meters are interchangeable in external connections with corresponding watthour meters.

Advantages of Thermal Demand Meters—The thermal-demand meter has certain advantages over the integrated-demand meter. The principal advantages are simplicity of operation and lower maintenance due to fewer moving parts. The danger of "peak splitting," which is possible with the integrated-demand meter, is eliminated in the thermal meter. This may not be of appreciable importance, since splitting of every peak in a period is unlikely. However, the load peaks are not necessarily repetitive.

Recording Demand Meters—In recording demand meters, the demand of each interval is permanently recorded for future reference. The demand may be recorded on strip charts, printed tape, punched tape, or magnetic tape.

Punched tape and magnetic tape recorders are relatively recent developments for application in load survey recorders. Such recording demand meters are for a special application and are discussed under that topic.

Most recording demand meters make use of strip chart recorders. Usually the recorder is applied with one or more watthour meters as a unit to register kilowatt hours, varhours, or kilovolt-ampere hours, and to record the integrated-demand in units of some quantity which has been integrated. More than one recorder may be applied in a meter where a continuous record of the demand of more than one commodity is desired.

Recording demand meters are available in various combinations of watthour meters, varhour meters, and recorders, from which the arrangement desired can be selected. The various combinations are:

1. Single watthour (or varhours) meters with recorders for recording kilowatt or kilovar reactive demand.

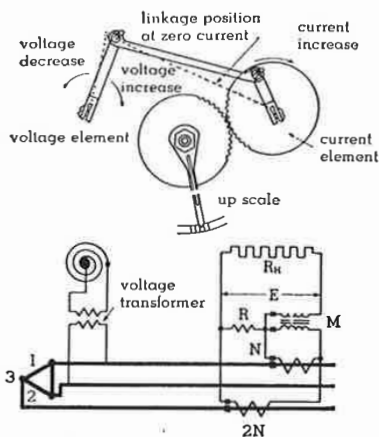

Fig. 39—Basic arrangement of thermal kva-demand meter.

2. Duplex meters comprised of two watthour meters and individual recorders with a common timer and drive mechanism for metering in-out energy and kilowatt demand, metering energy and integral of reactive power (kvah) and recording demand of each.
3. Totalizing metering of two separate circuits, in which the total energy used is registered and the demand of the combined loads is recorded.
4. Duplex, totalizing or two circuits in which the total energy used and energy used in one circuit are registered separately; the demand of the combined circuits is also recorded.
5. Kva recording demand meters composed of a watthour and varhour meter, vector addition mechanism, for obtaining the vector sum of the integrals with respect to time of kilowatts and kilovars.

KVA Demand Meter²⁸—The vector addition kva demand meters are so unusual that they justify special consideration. By means of the fascinating vector addition ball mechanism, the rotation of watthour and varhour meters are added vectorally to provide a rotation, the speed of which is proportional to kva. The ball mechanism also provides the indicated load power factor. The output rotation of the ball mechanism is proportional to the integrated kva. It is totalized to give kvah registration and integrated kva demand. An analysis of the vector addition ball mechanism and the kva demand meter are given in references 14 and 28. The vector addition kva-demand meter is available in both indicating and recording demand meters, which are Westinghouse Types RK and RI, respectively. The Type RK and RI demand meters are shown in Fig. 40.

The measuring devices of the RK and RI meters are very similar. The principal differences are in the data presentation of integrated-kva demand of the quantities registered. Both meters contain a watthour meter and a varhour meter which supply the inputs to the vector addition ball mechanism. The data presented by the Type RK indicating kva-demand meter are (1) maximum integrated-kva demand, either (indicating or cumulative); (2) kwh registration; (3) kvah registration; and (4) power factor indication. The data obtained from the Type RI recording kva-demand meter are (1) recorded integrated kva demand; (2) recorded integrated-kw demand; (3) kwh registration; (4) kva hour registration; (5) kvar hour registration; and (6) indicated power factor.

Types RK and RI meters are available with both 2-stator and 3-stator watthour and varhour meters for application to various three-phase systems. The Type RI is also available with 4-stator watthour and varhour meters for totalizing two three-phase circuits.

Due to the unusual amount of data obtained from the kva-demand meters and the commensurate additional cost, the kva-demand meters are applied only where the additional data are required.

Relative Expense of Demand Meters—The relative expense for various types of demand meters can be seen from Fig. 41. Each bar represents a particular type or

class of meter, although all types are for metering the same type of circuit. Since the recording meters are available only for polyphase meters, the meters represented by the particular bars are all polyphase meters. The indicating and cumulative demand registers are included for completeness.

VI. METER CONSTANTS AND TEST DATA

16. Meter Constants^{8, 22}

The principal constants of a watthour meter are: (1) the register constants, (K_r); (2) the watthour constant (K_h); (3) Wattsecond constant or test constant (K_s);

(4) the register ratio (R_r); and (5) the gear ratio (R_g). The definitions as given here have been extracted from American Standard Definition of Electrical Terms, Group 30, Instruments, Meters, and Meter Testing, ASA 642.30—1957.

Register Constant (K_r)—The register constant is the factor by which the register reading must be multiplied in order to provide proper consideration of the register, or gear ratio and of the instrument transformer ratios to obtain the registration in the desired units.

Watthour Constant (K_h)—The watthour constant of a watthour meter is the registration expressed in watthours corresponding to one revolution of the rotor.

Wattsecond Constant (K_s)—The wattsecond constant of a watthour meter is the registration in wattseconds corresponding to one revolution of the rotor.

Register Ratio (R_r)—The register ratio is the number of revolutions of the wheel meshing with the worm or pinion on the rotor for one revolution of the first dial.

Gear Ratio (R_g)—The gear ratio is the number of revolutions of the rotor for one revolution of the first dial.

Relationships Between Meter Constants—The relationships between the watthour meter constants is given by the following:

- 1) $K_r = \text{register constant} = \frac{\text{Measured Kwh}}{\text{Registered Kwh}}$
- 2) $N = \text{Numerical value of one revolution of the first dial pointer (Usually } N = 10\text{)}$
- 3) $K_h = \text{Watthour Constant} = \frac{\text{Watthours}}{\text{Rev of rotor}} = \frac{\text{Kwh} \times 1000}{\text{Rev of rotor}} = \frac{1000 \times \text{Kw (rated full load or load}_x\text{)}}{60 \times \text{rotor rpm (at rated full load or at load}_x\text{)}}$

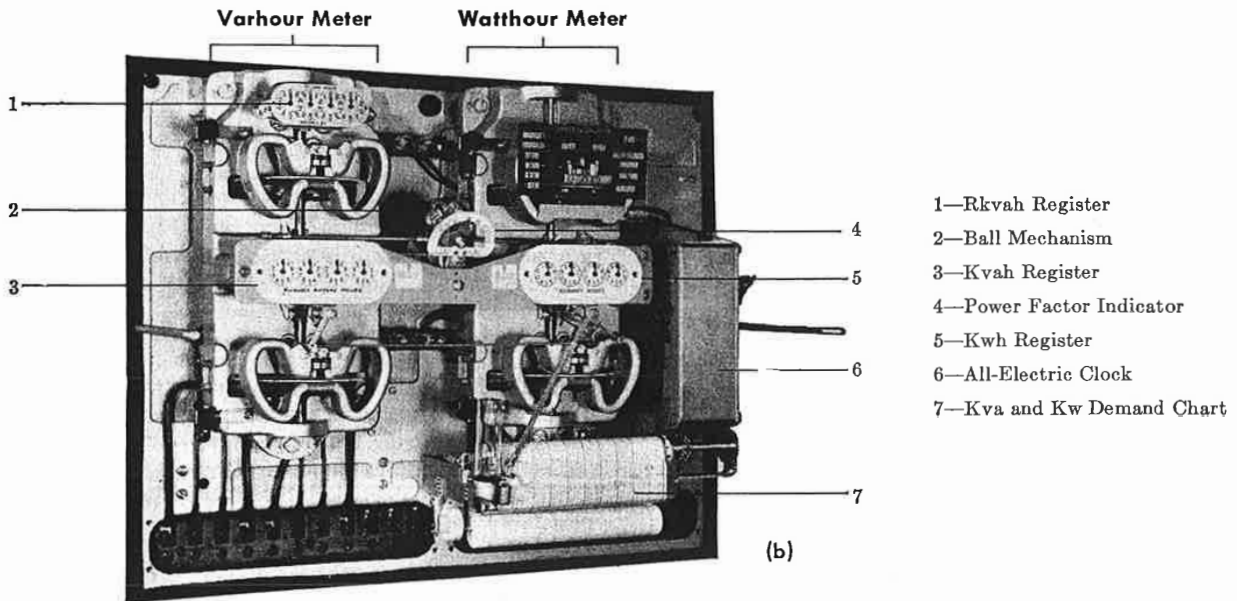
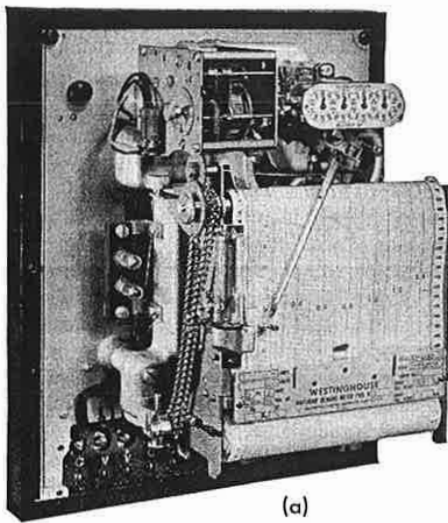

Fig. 40—Vector addition, integrated kva demand meters, (a) Type RK, (b) Type RI.

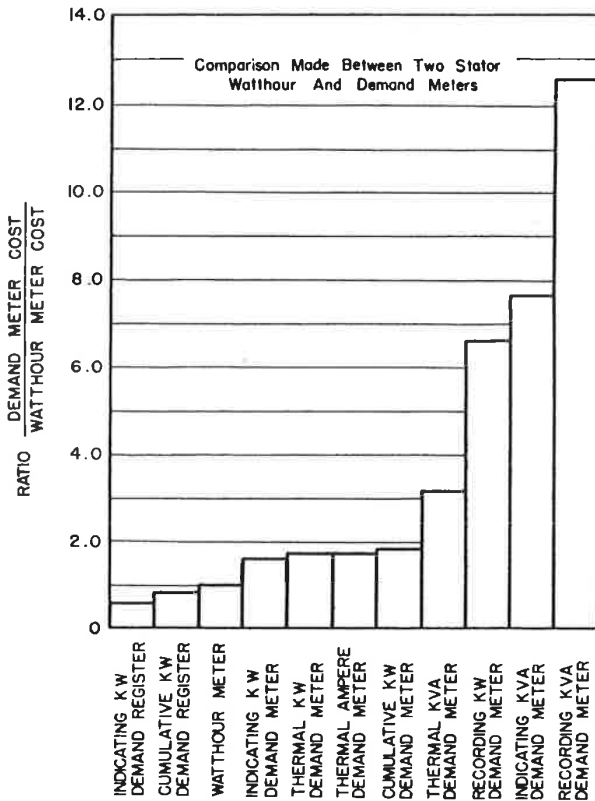

Fig. 41—Relative cost of demand meters.

- 4) $K_s = \text{Wattsecond constant or test constant}$

$$= \frac{\text{Wattseconds}}{\text{Rev of Rotor}}$$

$$= 3600K_h$$
- 5) $R_g = \text{Gear ratio}$

$$= \frac{\text{Rev of rotor}}{\text{Rev of 1st dial pointer}}$$
- 6) $R_r = \text{Register Ratio}$
 = The ratio of the number of revolutions meshing with the worm or pinion of the disk shaft to the number of revolutions of the first dial pointer.
- 7) $K_r = \frac{K_h R_g}{1000N} = \frac{K_h R_g}{10000}$ (Usually $N = 10$)

17. Meter Testing

In order to register correctly the energy and reactive kilovar hours delivered to a load, the number of revolutions of the rotating disk of the meter must be proportional to the quantity being metered, and the number of revolutions of the disk must be accurately registered. Transformer rated meters must be calibrated for application with the particular instrument transformers. Usually transformers of high accuracies are applied, so that transformer errors may be neglected in calibration of the meter. Also, modern instrument transformers are

not subject to changes in accuracy unless the transformer is mechanically injured. Testing of metering equipment, therefore, consists primarily of calibration of the watthour meters.

Testing a watthour meter consists of: (1) calibrating the meter so that the number of revolutions of the rotating disk is correct within the established tolerance for a given amount of energy delivered to the load, or that the speed of the disk is proportional to the load being measured; (2) the number of revolutions of the rotating disk is properly translated to the register, so that the energy delivered to the load is accurately registered on the watthour meter.

Testing of a demand meter consists of: (1) checking the interval of a block interval meter; (2) making usual tests on watthour meter with which the demand register is applied, except for lagged demand meters which are independent of the watthour meter; and (3) checking calibration of lagged-demand meters. In addition to the calibration check, testing a meter includes inspection of the meter and required repairs. After the repairs are made, the meter is calibrated.

Watthour meter tests may be classified as to: (1) the place of test, such as the laboratory or shop test or the field test (in customers' premises); (2) the time of the test, such as at or near the time of the installation, or periodic (routine); or (3) the reason for the test, as of customers' request, company (utility) request, referee (regulating agency), or test following repairs.⁸

Meter Test Methods^{14, 29, 30}—Two fundamental methods are used to test meters by a user. First, a meter can be tested by using indicating instruments (watthour, voltmeter, and ammeter) and a stop watch. The energy delivered to a load can be computed if the time is accurately measured and the power transferred is held constant. The time required for a given number of revolutions of the disk is measured, and the watthour constant of meter is computed and compared with the nameplate value. The requirement of holding the load constant is an undesirable condition necessary for this method. The second and more widely used method of testing a watthour meter consists of comparing the responses of the meter under test (test meter) and a standard watthour meter (standard meter) when measuring the same load. Usually the measurements are made on a phantom load. Rated voltage is applied to the potential circuits, and current at a low voltage of a specified value and phase relationship with respect to potential circuit voltage is circulated through the current circuits of the two meters in series.

Two methods are used to compare the response of the standard and test meters. In the first method, known as portable standard meter method, the number of revolutions of the standard meter is compared with the number of revolutions of the test meter. In the second method, known as the stroboscopic method, the respective speeds of the rotating disks of the standard and test meters are compared; the test meter is adjusted until the disks of both meters rotate at the same speed. In order to make "as found" test, the stroboscopic method requires a variation (calibrated in per cent registration)

in the voltage applied to the standard meter in order for both meters to rotate at the same speed.

The equipment required for the portable standard watthour meter method is less expensive than the equipment required for the stroboscopic method. However, the stroboscopic method is faster, since less time is required for comparing the relative speeds of the standard and test meters. The stroboscopic method of meter testing finds application in meter shops which do a large volume of meter testing. It is especially adaptable to gang testing. The method is not restricted to a particular type of meter, except that the marking or slotting of the disk is necessary. Disks of newer types of meters are marked for this purpose.

Meter test procedures are described in detail in literature available from manufacturers of test equipment. The procedure detailed usually applies to a particular test set. However, the procedure for testing of individual meters by use of the standard meter is fairly standard. A brief discussion of these tests is included here.

Individual Meter Test Procedure—As previously stated, the portable watthour meter test method consists essentially of comparing the number of revolutions at the test meter with the number of revolutions of a standard meter. The registration of a given meter is proportional to the number of revolutions. In order for a meter to register correctly, the gear ratio is dependent upon the watthour constant's being the values shown on the nameplate. Therefore, the registration is proportional to the watthour constant and the number of revolutions of the disk. This also applies to the standard meter. If the standard meter registers correctly, the registration of test meter is given by Equation 37

$$\% \text{ Reg} = \frac{k_h r}{K_h R} \times 100 \quad (37)$$

where

k_h = the watthour constant of the meter under test

r = the number of revolutions of the meter under test

K_h = the watthour constant of the standard meter

R = the number of revolutions of standard meter

In comparing a test meter and a standard meter which have watthour constants of k_h and K_h , respectively, a definite ratio R_o/r exists for 100 per cent registration of the test meter. The ratio R_o/r is the ratio of the number of revolutions of standard meter to the number of revolutions of test meters, respectively. Conversely, for a given r , the standard meter will make R_o revolutions if the test meter registers correctly. Therefore, the registration of the test meter is given by Equation 38

$$\% \text{ Reg} = \frac{R_o}{R} \times 100 \quad (38)$$

where R = the number of revolutions of standard meter in a test. Since R_o/R is very near unity, it is convenient to express the registration by Equation 39.

$$\% \text{ Reg} \approx \left(1 + \frac{R_o - R}{R_o}\right) \times 100 \quad (39)$$

In order to simplify determining the registration of a meter, the standard meters are supplied with accuracy tables or comparison scales from which the registration can be easily determined. Each scale or table is based upon Equation 38 and is applicable for particular values of K_h , k_h , r and R . For an observed R , the registration is read from the table or scale.

Obviously, r must be an integer. It has been found that it is convenient if r for full load test is also a multiple of 5. Also, it has been the general practice to permit the test meter to rotate a sufficient number of revolutions, so that the standard meter will rotate at least ten revolutions in order to detect inaccuracies of a fraction of a per cent. It is convenient for application of Equation 39 that R_o be a multiple of 10.

Meter Tests⁸—The usual tests at which a single-phase meter is calibrated are: 1) Full load, unity power factor; 2) Full load, 50 per cent power factor; and 3) Light load (about 10 per cent of full load), unity power factor. For tests which are made on the customer's premises, the power factor test is usually omitted, because three-phase power for making the 50 per cent power factor test is not usually available.

Polyphase meters are normally subjected to the same tests made on single-phase meters, because polyphase meters can be conveniently tested as a single-phase meter. Such a test on a polyphase meter can be made, using a single-phase standard meter, by paralleling the potential circuits of the test meter and connecting the current circuits in series or testing each stator separately. However, the polyphase meters are subjected to an additional test to balance out any irregularities in the levels of the driving torque of the individual stators. Details of this test are described in meter test procedures, which are usually available from manufacturers of test equipment.

Testing Demand Meters—The testing of integrated-demand meters consists of measuring the demand interval and the rate of chart travel for a recording meter. The watthour meter is tested in the usual manner of testing that type of meter. The permissible deviations in demand and demand interval are usually the same, which is ordinarily much greater than the percentage error in the watthour meter.

The testing of lagged-demand meters consists of calibrating the meter for accuracy of demand measurements. The demand interval of a lagged-demand meter has been considered to be the time required for a meter to indicate ninety per cent of the full value of a constant load suddenly applied. The demand interval of a thermally lagged-demand meter is determined by the thermal characteristics of the meters which are not adjustable. A thermally lagged-demand meter is usually tested by comparing its response with the response of a previously calibrated meter.

VII. SPECIAL METERING

18. Metering Off-Peak Water Heater Loads.¹³

The rate schedules of some utilities include special rates for off-peak water heater (o.p.w.h.) loads, which

are lower than the usual rate for the particular classes of load being served. The off-peak rate may be applicable on one or both elements of a two-element heater. In two-element heaters, the respective heater thermostats usually are interlocked so that only one element can be "on" at a time. Both or only the primary (lower or smaller) element may be restricted. Metering off-peak water heater loads applies only to metering the restricted element. Four general methods are employed for metering the o.p.w.h. load. These are as follows.

- 1) Separate meter and time switch control for the o.p.w.h.
- 2) Combination single register meter and time switch which meters both the house and o.p.w.h. load and controls the o.p.w.h. only.
- 3) Combination two-rate register meter and time switch which meters the house load at o.p.w.h. load during off-peak at off-peak rates, controls the o.p.w.h., and meters the house load during on-peak at on-peak rate.
- 4) Combination two-rate register meter without water heater contacts, in which the water heater is unrestricted, the house and w.h. are metered on the same meter at the same rate, and on-peak and off-peak load consumptions are indicated on separate registers.

The schematic diagrams of connections for the various methods of metering off-peak water loads are shown in Fig. 42.

19. Loss Metering and Compensators³¹

In some metering applications, it is desirable either to determine the energy loss in a transformer or to compensate for the loss. Loads served at primary voltage are applications for the loss compensator. Due to the difference in the costs of the instrument transformers rated at primary service voltage and instrument transformers rated at utilization voltage, it is more economical to do the metering at utilization voltage. However, the connection point (metering point) for services served at primary voltage is on the primary side of the distribution transformer or substation. Such services can be metered at secondary voltage if the transformer losses are metered, or transformer loss compensation is applied to the low-voltage metering.

Compensation of the total transformer losses consists of developing additional driving torques in the low-side metering proportional to the transformer core and copper losses. The core loss is very nearly proportional to the square of the voltage; the copper is proportional to the square of the current. The object of transformer loss compensators is to apply to the normal low-side watt-hour meter quantities which result in additional driving torques proportional to E^2 and I^2 , without altering the driving torque which is proportional to the low side kilowatt load. Analysis of the principles and applications of transformer loss compensators is given in reference 31.

20. Totalizing and Remote Metering.^{32, 33, 34}

Where it is necessary to determine either the total of

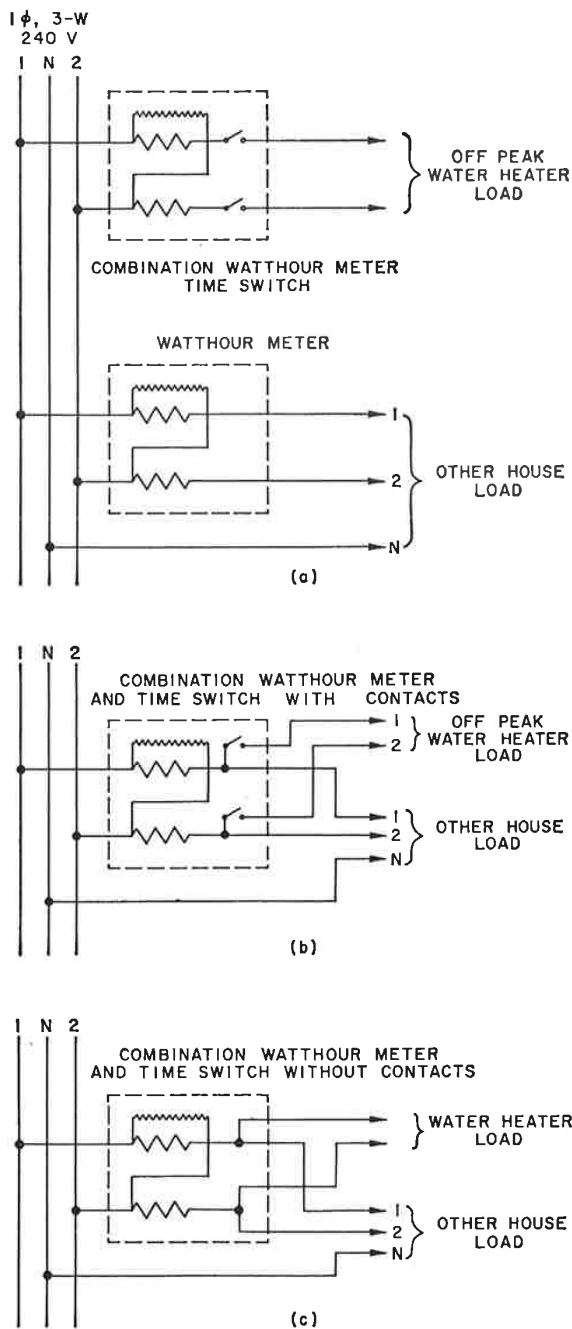

Fig. 42—Diagram of various arrangements for metering off-peak water heaters.

metered quantities (kwh, rvarh, or demand quantities) on different circuits, or to indicate the metered value at a point remote from the metering point, totalization or remote metering is required. Totalizing and remote metering are two separate and distinct applications, although a particular application may be either or a combination of both applications. However, totalizing and remote metering are treated independently here.

Although totalization may be applicable to other measurements, this treatment is restricted to demand and energy or other integrated quantities mentioned above. Accepted terms are used to classify totalization in certain respects, while remote metering is a general term. Totalization is classed, according to the proximity of the circuits to be totalized, either as local totalization or remote totalization. Totalization is also classed according to the method of totalizing, as mechanical, electrical, or impulse totalizing. No distinction is made between remote metering and telemetering, although telemetering is usually associated with a particular method of accomplishing the more general requirement of remote metering. Telemetering is usually associated with carrier current transmission channels rather than with wire channels, although the association might be erroneous and misleading. Remote metering is applicable to remote presentation of measurements in general and is not restricted to remote totalization.

Totalization—Local and remote totalization are not clearly defined with regard to areas of application; however, local totalization implies that the metering points and the totalizing equipment are in the same immediate area, such that wire circuits are applicable for data transmission. On the other hand, remote totalization implies the application of telemetering or remote metering and totalization of measurements taken at individual but remote points. Therefore, remote totalization implies that individual metering and totalizing points are separated by several miles. Totalization as used here is restricted to local totalization; however, it may also be applicable to remote totalization in which the remote measurements are totalized at the receiver terminals of carrier current channels.

Methods of totalizing are clearly defined as mechanical, electrical, and impulse totalization, according to the principal method involved.

Mechanical Totalization—Mechanical totalization is the totalizing of mechanical quantities (usually torques or forces) into which electrical measurements have been translated. An example of mechanical totalization is the watt-hour meter for totalizing energy consumption on a 3-phase, 3-wire circuit and a single-phase circuit. The meter has the necessary stators for metering each circuit independently. The disks which are driven by the respective stators are coupled to a common shaft. Therefore, the torques developed by the stators associated with the respective circuits are totalized in the common shaft, which is geared to a common register to indicate the total consumption. The totalizing meter may be subjected to a much wider range of load than that to which an individual meter would be subjected. This may result in errors at extremely light and heavy loads. Economics normally limits to two the number of circuits to be mechanically totalized; however, in special applications, several circuits have been mechanically totalized. An advantage of mechanical totalization is that the circuits to be totalized can be independent with respect to the phase relationship of the voltages of the circuits to be totalized.

Electrical Totalization—Several circuits can be electrically totalized by paralleling the secondaries of the current transformers on corresponding phases of the circuits to be totalized. Electrical totalization is also subject to errors at extremely light and heavy loads, due to the wide range of loading to which the meter might be subjected. Also, electrical totalization is subject to additional errors because of variations in current transformer burdens, which may be due to one or more primary circuits being open or to wide variation in the loads on the individual circuits. These errors can be reduced to a minimum if the burden common to the transformers is kept to a minimum by paralleling the transformer secondary circuits at the meter terminals rather than at the transformer terminals. Errors can result from the additional burden imposed by excessively long transformer secondary leads. If this is the limiting factor of the number of circuits to be electrically totalized, it makes little difference if the current transformer external burdens are paralleled at the transformers or at the meter. One restriction of electrical totalization which does not exist with mechanical totalization is the requirement of correspondence of the phase voltages on the circuits to be totalized. The potentials required for metering can be supplied from one set of potential transformers; however, the potential source must be highly reliable and be available at any time a circuit to be totalized is energized.

A second restriction on electrical totalization is the requirement that the c.t. ratios in all circuits to be totalized must be equal. If the primary c.t. ratios are dissimilar, auxiliary totalizing current transformers must be interposed between the primary transformers and the meter to make the overall c.t. ratios of the circuits equal.

Circuits can also be electrically totalized by using meters with multiple current windings, so that a current winding is provided for each circuit to be totalized. The number of circuits to be totalized by multiple current windings or by paralleling current transformer secondaries is usually limited to two or three. Circuit diagrams showing the basic methods of electrical totalization are shown in Fig. 43.

Impulse Totalizing—Impulse totalizing consists essentially of translating the intelligence of measurements taken at the individual metering points into electrical impulses for transmission to totalizing relays or to a totalizing meter to obtain the aggregate of the measurements. By attachment of a contact device which momentarily makes and breaks its contacts for a specific number of revolutions of the disk, a watt-hour measurement is translated into electrical impulses, each cycle of which is proportional to the "kwh" at the metering point. The contact device momentarily makes and interrupts the circuit between the meter and the totalizing meter or relaying point to alternately energize and de-energize a solenoid. The solenoid advances a register or device for each impulse cycle to register the total number of impulses or kwh measurements received from the metering points. The transmission circuit (the circuit containing the contact devices, solenoids, and the

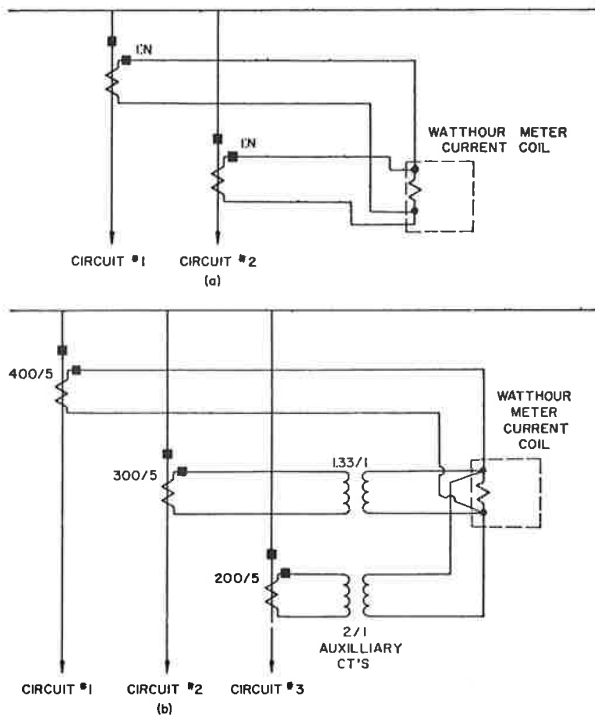

Fig. 43—Circuit diagrams of basic methods of electrical totalization.

connecting conductors) may be low voltage and either a.c. or d.c. The transmission circuit must be highly reliable, so that voltage is available to the data transmission channel at any time a circuit to be totalized is energized. The number of impulses registered in a given interval is proportional to the aggregate demand of all circuits totalized. The aggregate demand can be either indicated or recorded.

Data Transmission Circuit—Either of two basic types of circuits is used for transmission of the impulses to the totalizing relay or meter circuit. These are the two-wire circuit or the three-wire circuit. Either a.c. or d.c. voltages can be applied to both basic circuits. However, a.c. is preferred, because it results in less wear on the contact devices and has the additional advantage of being available for synchronizing the chart or timing mechanism for demand measurements at the metering and totalizing points. Circuit diagrams of the basic types of data transmission channels and variations in 3-wire transmission channels are shown in Fig. 44. The choice of the data transmission channel and contact devices is influenced by the requirements of the totalization receivers. The manufacturer of the totalization equipment should be consulted for his recommendations and details of requirements.

Impulse-Operated Metering Apparatus—Westinghouse impulse meters are available to correspond with the various watthour meters and block interval demand meters. However, only one type of totalizer is required for each general type of watthour-demand meter, regardless of the types of circuits being totalized. Westing-

house impulse-operated metering apparatus is of the low-rate type, i.e., less than 50 impulses per minute. Contact devices mounted on watthour meters are connected directly to the impulse receivers without the use of auxiliary equipment. Various combinations of contact devices, totalizing relays, and receivers can be made to meet the requirements of particular applications. In impulse totalizing, it is not necessary that the transmitting meters be of the same type as the receivers. However, the transmitting meters must be equipped with suitable contact devices for application with the transmitting channel and receiving equipment. Either the transmitter or the receiver, or neither, may be a recording or indicating demand-watthour meter. Also, the receiver (totalizer) may be only an indicating demand meter.

The type WRA impulse recorder is of the double operating coil type and totalizes the impulses from two

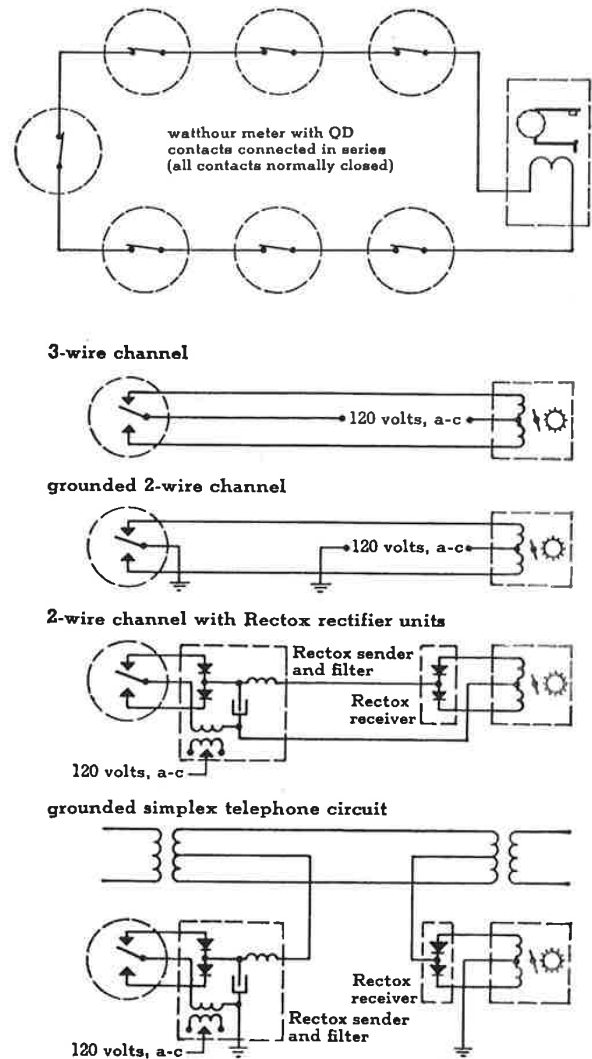

Fig. 44—Basic impulse totalization data transmission circuits.

separate contact devices. If more than two circuits are to be totalized, a WT totalizing relay must be used. The type WT impulse totalizing relay adopts the modern concepts of semi-conductor devices and logic elements to combine and retransmit impulses from a number of sources to a single circuit or receiver. It is available in units to totalize from three to seven input circuits, and may be used to totalize two input circuits. Such input impulses may originate from any 3-wire contact device or single-pole-double-throw impulse device relay. Input-to-output ratios of 1 to 1, 2 to 1, and 4 to 1 are provided. The WRA receives kwh impulses, totalizes kwh, and records totalized kw demand. A duplex WRA meter, consisting of two WRA meters in one case, is available for receiving both kwh and rkwh impulses, totalizing each commodity, registering the total of each, and recording the totalized demand of each.

Auxiliary relays are available for application with the type WT impulse totalizing relay. The type WS impulse storage relay is used when impulses cannot be continuously transmitted because of temporary use of transmission lines for other purposes. This device makes use of a stepping motor as its impulse-actuated driving element, and stores up to approximately 500 impulses. The type WD impulse difference relay is used when a difference between impulses from two sources is to be accomplished and the difference is re-transmitted. The type WD relay makes use of two stepping motors as its operating elements.

The type WRI impulse operated kva receiver is essentially the RI recording watt-hour demand meters, with the watt-hour and var-hour elements each replaced with a two-circuit (three-wire) totalizing relay. Each relay consists of two pairs of operating coils, with a differential mechanism which totalizes the output. One two-circuit relay totalizes the kwh impulses; the other relay totalizes the kvah impulses. The outputs of the totalizing relays drive a modified RI register- and ball-mechanism, which is described under Recording Kva Demand Meters. The WRI meter registers only the kwh and kvah, whereas the RI also registers the rkwh.

The WRA and WRI impulse totalizing meters require three-wire transmission channels, or the 2-wire modified channel in which a rectox filter unit is applied. Where direct connection is made between the senders and receivers with a 120-volt a.c. supply, it is recommended that the resistance of the loop not exceed 1000 ohms. The totalizing relay coils require approximately .080 ampere at 60 cycles for correct operation. This corresponds to a maximum loop distance of approximately 5.6 miles of #22 twisted pair copper conductors, and approximately 11.25 miles of #19 twisted pair copper conductors.

Westinghouse impulse operated indicating demand meters are available in the various types of mountings and various types of registers which might be required. The meter is essentially a watt-hour demand meter in which the meter stators and magnets are replaced by a single coil notching relay which moves a notch for each impulse cycle. The various types of Westinghouse impulse operated demand meters are shown in Table 5.

21. Load Survey Recorders

The load survey recorder is a special meter which was developed principally for the purpose of obtaining load data for use in making rate studies. Therefore, it should be of particular interest to electric utility rate engineers. The object of the development was to produce a recording demand meter which would record the data in such a manner that it could be readily processed on high speed data processing machines.

At present, two types of load survey recorders are available in which the data are recorded differently on each meter. The recorders used on these meters are (1) magnetic tape recorder, and (2) punched tape recorder^{35, 36}. Load survey recorders differ in the manner in which the data is obtained by the meter, i.e., the measurement of the demand is made within the load survey meter, or it is made on an auxiliary watt-hour meter and translated into impulses by a contact device for application to the recorder. The load survey recorders either measure and record, or only record the integrated or block-interval kilowatt-demand. The function of the meter varies with different manufacturers. Survey recorders have two characteristics in common, which are (1) the quantity recorded is integrated kilowatt-demand and (2) a translator is required for translating the data to punched cards or punched tape for use on data processing machines.

DSL



DSL: Socket type to replace customer's meter, complete with DS meter and contact device.

DSL-5



DSL-5: Socket type to replace customer's meter with type DS-5 meter and contact device.

DSL D



DSL D: Same as DSL except with additional socket for retaining customer's meter for revenue billing.

DSL D-5



DSL D-5: Same as DSL-5 except with additional socket for retaining customer's meter for revenue billing.



DAL



Recorder unit in a separate box enclosure with flexible cable for use with other than socket type meters. Also used where impulse source is not a watt-hour meter.

Fig. 45—Various arrangements available in the Westinghouse Load Survey Recorder.

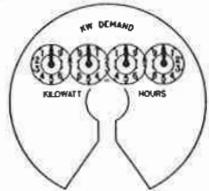
Table 5—Available Westinghouse Impulse Operated Indicating Demand Meters

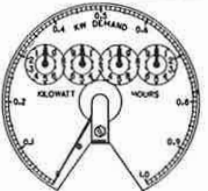
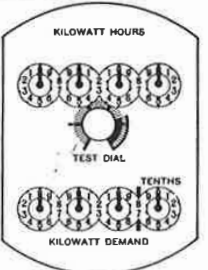
Application:	Meter Type			
	Kilowatt hours	Indicating Kw Demand	Kilowatt Hours Indicating Kw Demand	Kilowatt Hours Cumulative Kw Demand
dial plate:				
type of case				
bottom-connected meter case	WA	WA-1	WA-2	WA-3
glass projection switchboard	WB	WB-1	WB-2	WB-3
Flexitest switchboard	WB-F	WB-1F	WB-2F	WB-3F
instrument switchboard	WM	WM-1	WM-2	WM-3

The Westinghouse Load Survey Recorder applies magnetic tape as the recording means. The tape is driven by a synchronous motor, so that in case of interruption of service to a load being recorded, the tape movement stops and the interruption is recorded. Upon restoration of service, the tape resumes its movement. A clock which is driven by the tape-driving motor indicates the total duration of interruptions of service. Tapes are available in either 8-day (150 ft.) or 32-day (600 ft.) reels.

The kilowatt load data is fed to the Load Survey Recorder in the form of impulses from a contact device in the associated watthour meter. The number of impulses recorded in specific given intervals is proportional to the energy consumption and average kilowatt load (demand) in that interval. The source of impulses is dependent upon the particular application of the recorder.

The Westinghouse Load Survey is available for application to a variety of conditions, depending upon the permanent metering which is installed at the point where the load is to be recorded. The recorder is available as a complete unit, type DSL, with watthour meter with contact device and the tape recorder, for socket mounting to replace the customer's meter. In another arrangement, type DSLD, the watthour meter and recorder units are mounted in a trough which contains an additional socket for installation of the existing watthour meter, such as the customer's meter. The recorder is available in type DAL, which includes recording unit and integrating meter with flexible cable connection for use with other than socket-

type meters or where the impulse source is not a watthour meter. The socket-mounted load survey recorders are available for application to single-phase loads (using type DS watthour meter) type DSL or three-phase loads (using DS-5 watthour meter) type DSL-5, 2-stator network meter. Arrangements of the Westinghouse Load Survey Recorder are shown in Fig. 45. The internal circuit diagrams are shown in Fig. 46.

The magnet tape record is processed to translate the data to either punched cards or punched tape. A 600 ft. tape can be translated to punched cards in thirty-two minutes, or to a punched tape in 16 minutes. The translation to punched cards is done in the type WLT-1 translator, used in conjunction with an IBM-526 printing summary punch machine. Translation to punched tape is done in the type WLT-2 translator. Two plans are available for translating the tapes into punched cards. The translator can be purchased, or a rental service is provided for translating the tapes.

The punched card output contains information required for processing the data. The card is designed so that the measured demand is punched in certain columns and other pertinent information is punched in assigned columns. A punched card is shown in Fig. 47 which also shows the addresses of data on the card. The card contains data for the intervals, so that six cards are required for recording 15-minute demands for a 24-hour day, or 3 cards are required for recording 30-minute intervals. The identification of the load measured and the time of measurement are among other pertinent data punched on the card.

VIII. INSTRUMENT TRANSFORMERS

This discussion of instrument transformers is general, with the emphasis on the application of transformers to metering and metering outfits.

22. Definitions

This definitions have been extracted from "American Standard Requirements, Terminology, and Test Code for Instrument Transformers," C57.13-1954³⁷. Where used in this presentation, the standard definition is intended.

FUNCTIONAL DEFINITIONS—

(1) Instrument Transformer. An instrument transformer is a transformer which is intended to reproduce in its secondary circuit, in a definite and known proportion suitable for utilization in measurement, control, or protective devices, the current (or voltage) of its primary circuit, with its phase relations substantially preserved.

(2) Potential (Voltage) Transformer. A potential (voltage) transformer is an instrument transformer which is intended to have its primary winding connected in shunt with a power supply circuit, the voltage of which is to be measured or controlled.

(3) Current Transformer. A current transformer is an instrument transformer intended to have its primary winding connected in series with a power supply circuit carrying the current to be measured or controlled.

RATING—

(1) Burden of an Instrument Transformer. The burden of an instrument transformer is that property

of the circuit connected to its secondary winding which determines the active and reactive power at its secondary terminals. The burden is expressed either as total ohms impedance together with the effective resistance and reactance components of impedance or as the total volt-amperes and power factor of the secondary devices and leads, to a specified value of frequency and current or voltage. The impedance expression is more applicable to current transformers, the volt-ampere power factor to potential transformers.

(2) Accuracy Burden Rating. The accuracy burden rating of an instrument transformer defines a burden which can be carried at a specified accuracy for an unlimited period without causing the established limitations to be exceeded.

(3) Thermal Burden Rating of a Potential Transformer. The thermal burden rating of a potential transformer is the volt-amperes which the potential transformer will carry continuously at rated voltage and frequency without causing the specified temperature limitations to be exceeded.

(4) Quarter Thermal Burden Ambient Temperature for a Potential Transformer. The quarter thermal burden ambient temperature is the maximum ambient temperature at which the transformer can be safely operated when the transformer is energized at rated voltage and frequency and is carrying 25 per cent of its thermal burden rating without exceeding the specified temperature limitations.

(5) Rated Primary Voltage of a Potential Transformer. The rated primary voltage of a potential (voltage) transformer is the voltage selected for the basis of performance specifications.

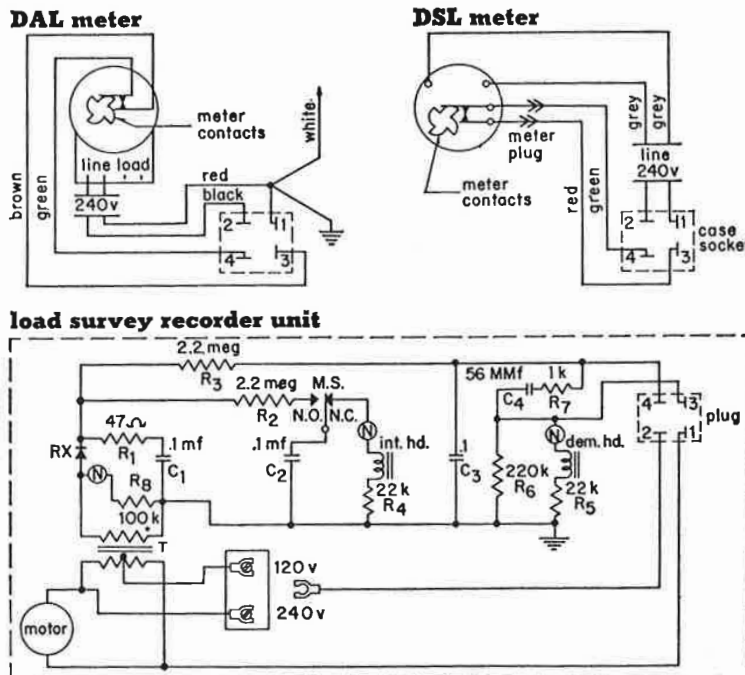

Fig. 46—Internal circuit diagram of a Westinghouse Load Survey Recorder.

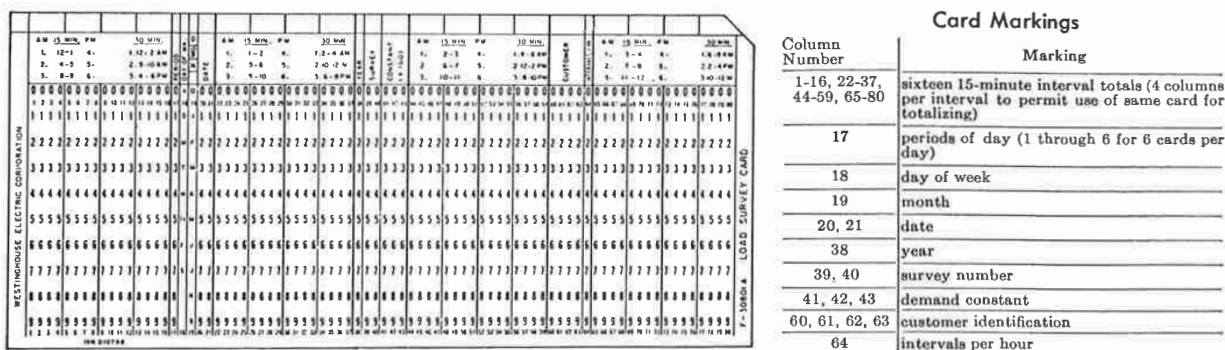

Fig. 47—Punched card obtained for translation of Load Survey Recorder tape showing addresses of data on card.

(6) Rated Primary Voltage of a Current Transformer. The rated primary voltage of a current transformer designates the insulation class of the primary winding.

(7) Rated Primary Current of a Current Transformer. The rated primary current of a current transformer is the current selected for the basis of performance specifications.

(8) Continuous-Thermal-Current-Rating Factor. The continuous-thermal-current rating factor is the factor by which the rated primary current is multiplied to obtain the maximum allowable primary current based on the limiting temperature rise on a continuous basis.

(9) Phase Angle Correction Factor. The phase-angle correction factor is that factor by which the reading of a wattmeter or registration of a watt-hour meter, operated from the secondary of a current, or a potential transformer, or both, must be multiplied to correct for the effect of phase displacement of secondary current, or voltage, or both, with respect to primary values due to instrument transformer phase angles.

(10) Instrument-Transformer Correction Factor (Transformer Correction Factor). The instrument-transformer correction factor is the factor by which the reading of a wattmeter or the registration of a watt-hour meter must be multiplied to correct for the effects of the error in ratio and the phase angle of the instrument transformer. This factor is the product of the ratio and phase-angle correction factors for the existing conditions of operation.

23. Functions of Instrument Transformers

In a particular application, an instrument transformer performs either or both of two principal functions. It may be necessary to transform the electrical quantities (voltage and current) to be measured, relayed, or controlled, individually or as functions of both individual quantities, into quantities which are suitable for application to standard meters and relays, or control devices. Neither the satisfactory operating range nor the insulation class of the instruments, meters, relays, etc. should be exceeded. The transformation may

be necessary because of the magnitude of the system quantities to be measured, or the voltage-to-ground of the point on the system may be such as to require insulating the instruments, meters, etc. from the system. The system quantities are referred to as *primary* quantities.

The transformation must be such that definite and known proportionalities and phase relationships exist between primary and secondary quantities. Measurements made on secondary quantities must be representations of primary measurements with known and acceptable accuracies. The accuracy requirements depend upon the purpose of the *measurements*. Metering used for billing purposes requires greater accuracy than measurements for protective relaying.

24. Classification of Instrument Transformers.

Instrument transformers are classified according to: 1) the particular function; 2) method of installation; 3) type of major insulation; 4) method of cooling; and 5) mechanical construction as shown in Table 6.²⁷ Each instrument transformer may be classified as being of one type listed under each major classification, with the exception of mechanical construction, which is applicable to current transformers only. The specific types in each classification are defined in the American Association Standard C-57.13-1954, from which the definitions in (22) have been extracted.

25. Potential Transformers.²⁸

Analysis—The function of a potential transformer is to produce a voltage which is applicable to standard instruments, meters, or relays, and which is a representation of the primary voltage in a known and acceptable proportionality and phase relationship. In general, the secondary voltage of a constant potential transformer is proportional to turns ratio, and in phase with or in phase opposition to the primary voltage (depending upon the reference terminal designation). Such would be the case of an ideal transformer, which has no leakage impedance, losses, or exciting current. However, in the actual constant potential transformer, the energy necessary to magnetize the magnetic circuit of the transformer must be supplied from the primary

lines through the leakage impedance of the primary winding. Also, the presence of load current in the transformer windings causes a voltage drop in the leakage impedance of the primary and secondary windings. Load current and exciting current produce an overall voltage drop in the transformer, which results in a ratio error and a phase angle other than 180° between primary and secondary terminal voltages.

In the usual analysis of an instrument potential transformer, the saturation effects may be neglected and the assumption of linear, bilateral impedances is valid. Although conditions may exist in which the effects of non-linearity are not negligible, such are abnormal conditions and are not discussed here. Usually the instrument potential transformer can be analyzed with reasonable accuracy by representing the transformer by the equivalent circuit shown in Fig. 48(a). The vector diagram resulting from sinusoidal applied voltage is shown in Fig. 48(b).

It becomes apparent from an analysis of the vector diagram that the secondary burden (magnitude and power factor) has a pronounced effect on the accuracy with which the secondary voltage represents the applied voltage. For an ideal transformer (without losses or impedance), the secondary voltage would be in-phase (or 180° out of phase) with the applied voltage; and the ratio of primary to secondary voltage would be equal to the turns ratio. However, the actual transformer has impedance and corresponding losses and internal voltage drops. The voltage drops due to exciting current I_e and load current I_2 cause the secondary voltage to be less than (for the usually lagging power factor burdens) and slightly out of phase with the primary voltage. Equations have been developed for calculation of the ratio and phase angle. However, I_e is usually so very much smaller than I_1 , and is very nearly constant, that it can usually be neglected without seriously affecting the accuracy. If I_e is neglected, the expressions for the true ratio and phase angle are both sufficiently linear functions of load current at a given voltage and burden power factor.

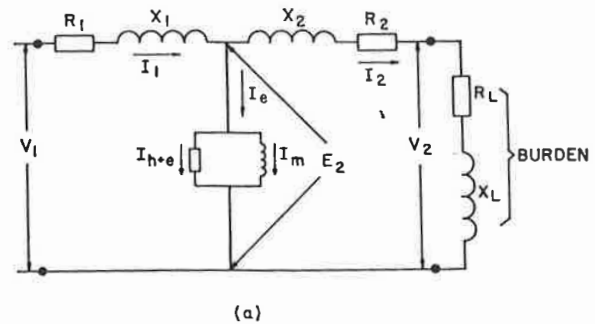

(a)

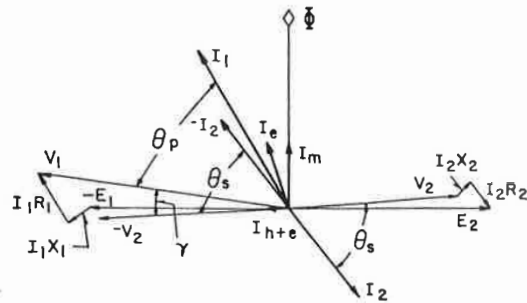

(b)

Fig. 48—(a) An equivalent circuit of an instrument potential transformer, (b) Vector diagram of (a).

Errors in Potential Transformers^{39, 40}—The ratio correction factor (*RCF*) of a potential transformer is that factor by which the marked ratio (ratio as indicated on the nameplate) must be multiplied to obtain the true ratio, V_1/V_2 , and is given by Equation 38.

$$RCF = \frac{V_1/V_2}{\text{Marked Ratio}} \quad (38)$$

The phase angle (γ) of a potential transformer is the angle between the secondary voltage from the identified

Table 6—Classification of Instrument Transformers

Major Function	Application		Classes of Instrument Transformers		Mechanical Construction*
	Method of Installation	Major Insulation	Method of Cooling		
(1) Potential	(1) Indoor	(1) Dry-Type	(1) Dry-Type Self-Cooled	(1) Wound (Wound-Primary) Type	
(2) Current	(2) Outdoor	(2) Compound-Filled	(2) Oil-Immersed Self-Cooled	(2) Bar Type	
	(3) Protected Outdoor	(3) Liquid Immersed		(3) Window Type	
				(4) Bushing Type	
				(5) Split-Core Type	
				(6) Three-Wire Type	

(1) Metering and Relaying

(2) Relaying

*Applies to Current Transformers Only.

to the unidentified terminal and the corresponding primary voltage. The angle is considered positive when the secondary voltage leads the primary voltage, or when $-V_2$ leads V_1 .

The phase-angle correction factor (*PACF*) of a potential transformer is that factor by which the apparent power factor must be multiplied to obtain the true (system) power factor. For positive transformer phase angles, $-V_2$ leads V_1 ; therefore for a lagging power factor load, the true power factor angle, θ_p , is less than the indicated power factor angle, θ_s . Assuming no ratio error exists, the phase angle correction factor for a potential transformer is given by Equation 39.

$$(PACF) = K_\gamma = \frac{\cos \theta_p}{\cos \theta_s} \quad (a)$$

$$K_\gamma = \frac{\cos (\theta_s - \gamma)}{\cos \theta_s} \quad (b) \quad (39)$$

$$K_\gamma = \frac{\cos \theta_p}{\cos (\theta_p + \gamma)} \quad (c)$$

where γ = transformer phase angle

$\cos \theta_p$ = true or primary system power factor

$\cos \theta_s$ = apparent system power factor as indicated on secondary side of the transformer

The (*PACF*) can be expressed in terms of the apparent system power factor angle θ_s (as indicated on the secondary side of the transformer), as is given by Equation 39(b). It can also be expressed in terms of the true system power factor angle θ_p , as is given by Equation 39(c). Since the apparent system power factor is known, some individuals choose to express the (*PACF*) in terms of θ_s . However, in regard to the standard accuracy classifications for metering service which are given in the standards on instrument transformers, the accuracy standards are based on the system power factor.

Since γ is usually very small of the order of minutes, K_γ can be given in terms of θ_s or θ_p with sufficient accuracy by Equations 40(a) or 40(b), respectively.

$$K_\gamma \approx 1 + \gamma \frac{\tan \theta_p}{3438} \quad (a)$$

$$K_\gamma \approx 1 + \gamma \frac{\tan \theta_s}{3438} \quad (b)$$

where γ is expressed in minutes.

The transformer correction factor (*TCF*) is the factor by which the reading on a wattmeter or registration of a watt-hour meter must be multiplied to correct for the effects of the error in ratio and phase angle of the potential transformer. It is numerically equal to the product of (*RCF*) and K_γ . The ratio of the true system power to the indicated system power (as indicated by a wattmeter, including the marked turns ratio) is given approximately by Equations 41(d) and 41(e), respectively.

$$TCF = \frac{P_t}{P_m} = \frac{V_1 I_m \cos (\theta_s - \gamma)}{(\text{Marked Ratio}) V_2 I_m \cos \theta_s} \quad (a)$$

$$TCF = \frac{V_1 I_m \cos \theta_p}{(\text{Marked Ratio}) \times V_2 I_m \cos (\theta_p + \gamma)} \quad (b) \quad (41)$$

$$\text{Marked Ratio} = \frac{V_1}{V_2 \times (RCF)} \quad (c)$$

$$\therefore TCF = (RCF) \times K_\gamma$$

$$TCF \approx RCF \left(1 + \frac{\gamma \tan \theta_s}{3438} \right) \quad (d) \quad (41)$$

$$TCF \approx RCF \left(1 + \frac{\gamma \tan \theta_p}{3438} \right) \quad (e)$$

In measurements of voltage only, the ratio error is the only error of importance. However, in the measurement of a quantity which is a function of the product of voltage and current (watt meters and watt-hour meters), the ratio error and phase angle are both involved. An *RCF* greater than unity indicates that the true turns ratio is greater than the marked ratio, and results in a low meter reading, based on the marked ratio. Positive phase angle results in low and high meter readings and *PACF* greater and less than unity for lagging and leading power factor loads, respectively.

Errors in a potential transformer depend upon the transformer burden, transformer impedance, degree of saturation of the core, and the magnetic properties of the core. Standards of accuracy classification at standard burdens have been established for rating a transformer with regard to accuracy when operated at rated voltage and frequency.

Ratings of Potential Transformers³⁷—The rating of a potential transformer includes: 1) rated primary voltage and ratio; 2) insulation class; 3) impulse level in terms of full-wave-test voltage; 4) standard accuracy classes at specified standard burdens, voltage, and frequency; and 5) thermal burden rating.

Standard values of (1), (2), and (3) are shown in Table 7. The rated primary voltage is the voltage used as the basis of performance specifications, which include the insulation requirements as well as its functional performance. Typical primary connections for potential transformers in Groups 1, 2, and 3 of Table 7 are shown in Fig. 49.

Standard accuracy classifications for metering service are shown in Table 8. The accuracy classification corresponds with the transformer correction factor. The standard burdens for potential transformers for accuracy rating purposes are shown in Table 9. Standard burdens are based on a secondary voltage of 120 volts for two winding transformers, and 69.3 volts for the tertiary winding of transformers having such a winding.

The standard accuracy classes for potential transformers for metering service are shown in Table 8. The standards take into account the effect of phase angle by allowing a larger phase angle if the ratio error is such that the error introduced in a product meter reading by the phase angle compensates for the ratio error. The effects of coordination of phase angle and ratio errors can be seen in the parallelograms shown in Fig. 50. The parallelograms indicate the limits of both phase angle and ratio error for the standard accuracy classes. The relationship of *TCF*, *RCF*, θ_p , and γ is given by Equation 41(e).

$$TCF \approx RCF \left(1 + \frac{\gamma \tan \theta_p}{3438} \right) \quad (41e)$$

The limits of *TCF* for various accuracy classes are given in Table 8 for ranges of indicated system power factors of from .6 to 1.0. If the limit of θ_p is considered, i.e., $\tan \theta_p$ is considered as ± 1.333 , the limits of γ are adequately expressed by Equation 42. The limits of *RCF* and phase angle apply within ± 10 per cent of rated voltage at rated frequency and from zero burden to rated burden on a 120-volt secondary base or 69.3-volt tertiary base.

$$\gamma = 2600 (TCF - RCF) \tag{42}$$

where

γ = limit of phase angle, minutes.

The parallelograms of Fig. 50 are based on Equation 42, rather than the more accurate expression which is given in Equation 41(b). The exact limits of *RCF* and phase angle are obtained by applying the limits of system power factor to Equation 41(b). Therefore, for a system power factor of 60 per cent, Equation 41(b) becomes

$$\cos (57.13^\circ + \gamma) = .6 \frac{RCF}{TCF}$$

Service Conditions Affecting Potential Transformer Errors Burden³⁸—The ratio is approximately linear with burden at constant burden power factor and voltage. Characteristics at various burden power factors meet at zero burden. This factor makes it possible to determine the characteristics of any burden power factor, if the characteristics are known for one power factor. This is discussed under Potential Transformer Application Data.

At a particular burden power factor, the angle of which is equal to the through impedance angle of the transformer, the phase angle is equal to the phase angle at zero burden for the usual range of burdens. However, for the same burden power factor, the rate of change of *RCF* with burden is maximum. At extremely low and high burden power factors, the effects of ratio and phase angle errors tend to compensate for one another in the measurement of power.

Frequency—Increasing frequency at a fixed voltage has little effect in the potential transformer characteristics, since it increases the voltage drop due to leakage flux and decreases the flux density and the required exciting current. Unless the frequency is more than doubled, the effect on performance is usually small.

Decreasing the frequency results in an increase in flux density and a corresponding increase in exciting current. A potential transformer should not be operated at less than about 95 per cent of rated frequency.

Temperature—The resistance of the windings increases proportionately to the absolute temperature. Therefore, the resistance drop and the corresponding error increase with temperature. Typical curves are usually based on a temperature of 50°C, which represents an average operating winding temperature. Measurements made at an ambient temperature of 20°C result in a resistance drop, which is low by 12 per cent.

Voltage—The accuracy of a potential transformer at other than rated voltage is influenced by the degree by which the exciting current deviates from the normal value. The accuracy characteristics are unchanged at reduced voltage. At abnormally high voltage, the excit-

ing current is excessive and may result in serious error. Normal voltage variations do not result in serious errors.

26. Current Transformers.

Analysis—The function of a current transformer is to produce a current which is applicable to standard instruments, meters, or relays, and which is a representation of the primary current in known and acceptable

Table 8—Standard Accuracy Classes for Potential Transformers for Metering Service*

Accuracy Class	Limits of Transformer Correction Factor	Limits of Power Factor (Lagging) of Metered Power Load
1.2	1.012–0.988	0.6–1.0
0.6	1.006–0.994	0.6–1.0
0.3	1.003–0.997	0.6–1.0

*ASA Standard C57.13–1954.

proportionality and phase relationship. The magnitude of the primary current may be within the range of the standard instruments; however, it may be necessary to use a current transformer to insulate the primary circuit from the instrument circuit, due to the voltage of the primary circuit. Conversely, although the voltage of the supply circuit may be suitable for application to an instrument, the magnitude of the primary current may exceed the ratings of standard instruments. It is then necessary to produce a current for application to the instrument which is smaller than the current in the supply circuit by a known and acceptable proportionality and phase relationship.

An equivalent circuit and the corresponding general vector diagram of a current transformer are shown in

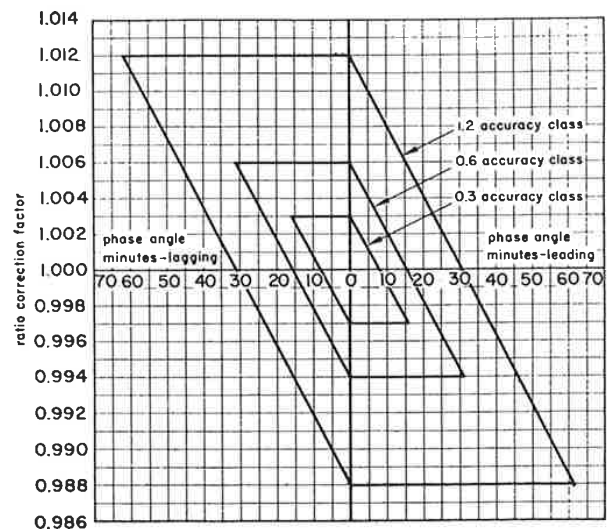

Fig. 50—Limits of ratio correction factors and phase-angle for standard accuracy classes for potential transformers for metering service.

Table 7—Standard Insulation Classes Marked Ratios, Primary Voltage Ratings and Dielectric Tests for Potential Transformers*

Nameplate Marking			Usual Circuit Voltage: Volts	Permissible Transformer Connection	Standard Dielectric Tests			
Standard Insulation Class: Kv	Standard Marked Ratio	Standard Primary Voltage Rating: Volts			Standard Low Frequency Test: Kv Rms	Standard Impulse Tests		Full Wave: Kv
						Crest Voltage: Kv	Min. Time to Flash-over: μ sec	
GROUP 1: 1.2 TO 15 KV, FULL INSULATION, Y VOLTAGE LIMIT EQUALS $\sqrt{3}$ TIMES Δ VOLTAGE LIMIT								
1.2	1:1	120/208Y	120	Δ or Y	10	36	1.0	30
	2:1	240/416Y	208 240	Y only Δ or Y	10	36	1.0	30
	4:1	480/832Y	416 480	Y only Δ or Y	10	36	1.0	30
	5:1	600/1040Y	832 600 1040	Y only Δ or Y Y only	10	36	1.0	30
5.0	20:1	2400/4160Y	2400 4160	Δ or Y Y only	19	69	1.5	60
8.7	35:1	4200/7280Y	4200 7280	Δ or Y Y only	26	88	1.6	75
	40:1	4800/8320Y	4800 8320	Δ or Y Y only	26	88	1.6	75
15L	60:1	7200/12470Y	7200 12470	Δ or Y Y only	34	110	1.8	95
	70:1	8400/14560Y	8400 14560	Δ or Y Y only	34	110	1.8	95
15H	60:1	7200/12470Y	7200 12470	Δ or Y Y only	34	130	2.0	110
	70:1	8400/14560Y	8400 14560	Δ or Y Y only	34	130	2.0	110
GROUP 2: 2.5 TO 345 KV, FULL INSULATION, Y VOLTAGE LIMIT EQUALS Δ VOLTAGE LIMIT								
2.5	20:1	2400/2400Y	2400	Δ or Y	15	54	1.25	45
5.0	40:1	4800/4800Y	4800	Δ or Y	19	69	1.5	60
8.7	60:1	7200/7200Y	7200	Δ or Y	26	88	1.6	75
15L	100:1	12000/12000Y	12000	Δ or Y	34	110	1.8	95
	120:1	14400/14400Y	14400	Δ or Y	34	110	1.8	95
15H	100:1	12000/12000Y	12000	Δ or Y	34	130	2.0	110
	120:1	14400/14400Y	14400	Δ or Y	34	130	2.0	110
25	200:1	24000/24000Y	24000	Δ or Y	50	175	3.0	150
34.5	300:1	34500/34500Y	34500	Δ or Y	70	230	3.0	200
46	400:1	46000/46000Y	46000	Δ or Y	95	290	3.0	250
69	600:1	69000/69000Y	69000	Δ or Y	140	400	3.0	350
92X	800:1	92000/92000Y	92000	Δ or Y	185	520	3.0	450
115	1000:1	115000/115000Y	115000	Δ or Y	230	630	3.0	550
138	1200:1	138000/138000Y	138000	Δ or Y	275	750	3.0	650
161	1400:1	161000/161000Y	161000	Δ or Y	325	865	3.0	750
196X	1700:1	196000/196000Y	196000	Δ or Y	395	1035	3.0	900
230	2000:1	230000/230000Y	230000	Δ or Y	460	1210	3.0	1050
287X	2500:1	287000/287000Y	287000	Δ or Y	575	1500	3.0	1300
345	3000:1	345000/345000Y	345000	Δ or Y	690	1785	3.0	1550
GROUP 3: 25 TO 345 KV, REDUCED INSULATION AT NEUTRAL END, GRD Y APPLICATION ONLY†								
25	120-200:1	14400 for 25000 grd Y	24000	grd Y only	50	175	3.0	150
34.5	175-300:1	20125 for 34500 grd Y	34500	grd Y only	70	230	3.0	200
46	240-400:1	27600 for 46000 grd Y	46000	grd Y only	95	290	3.0	250
69	350-600:1	40250 for 69000 grd Y	69000	grd Y only	140	400	3.0	350
92X	480-800:1	55200 for 92000 grd Y	92000	grd Y only	185	520	3.0	450
115	600-1000:1	69000 for 115000 grd Y	115000	grd Y only	230	630	3.0	550
138	700-1200:1	80500 for 138000 grd Y	138000	grd Y only	275	750	3.0	650
161	800-1400:1	92000 for 161000 grd Y	161000	grd Y only	325	865	3.0	750
196X	1000-1700:1	115000 for 196000 grd Y	196000	grd Y only	395	1035	3.0	900
230	1200-2000:1	138000 for 230000 grd Y	230000	grd Y only	460	1210	3.0	1050
287X	1500-2500:1	172500 for 287000 grd Y	287000	grd Y only	575	1500	3.0	1300
345	1800-3000:1	207000 for 345000 grd Y	345000	grd Y only	690	1785	3.0	1550

*These system voltages are not in the *EEI-NEMA Preferred Voltage Ratings for A-C Systems and Equipment* report (EEI R-6, NEMA 117).
 †For insulation class of neutral see per 13-11.541 ASA Standard C57.13—1954.

NOMINAL 3-PHASE SYSTEMS

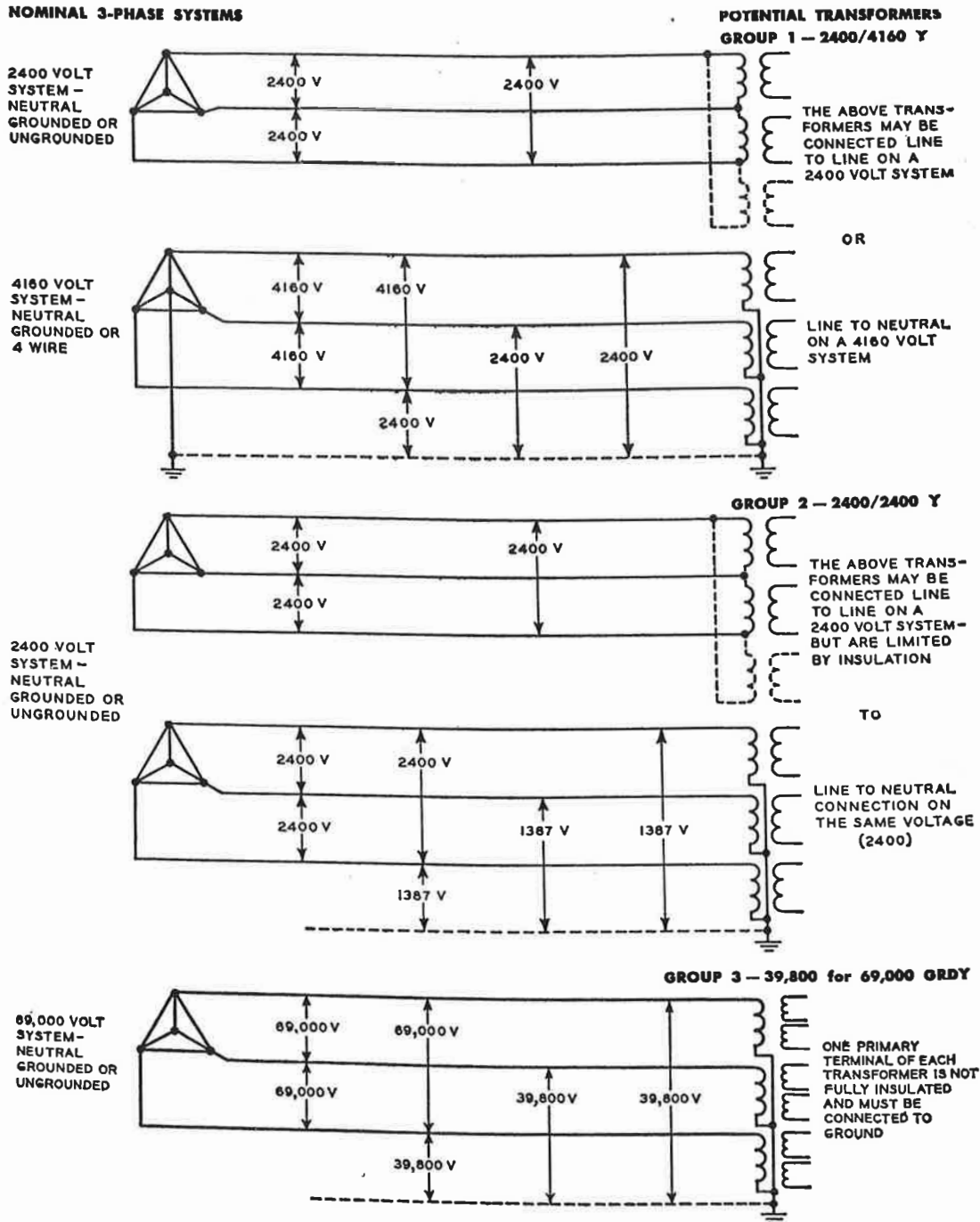

NOTE TO GROUP 3: The double ratio for the transformers in Group 3 is obtained by a secondary winding and a tertiary winding, to provide the same nominal voltage in the secondary from line to neutral as from line to line.

Fig. 49—Typical potential transformer primary connections for transformers in Groups 1, 2, and 3 of Table 7.

Fig. 51. Although the vector diagram in Fig. 48 for a constant potential transformer may be applicable to an analysis of a current transformer, Fig. 51 is preferable for this purpose, due to the fundamental differences in the transformers. In a potential transformer, the applied voltage, flux density, and exciting current are approximately constant, and the transformer current is determined by the leakage impedance of the transformer. In

Table 9—Standard Burdens for Potential Transformers*

Designation of Burden	Secondary Volt-Amperes	Burden Power Factor
W	12.5	0.10
X	25	0.70
Y	75	0.85
Z	200	0.85
ZZ	400	0.85

*ASA Standard C57.13—1954.

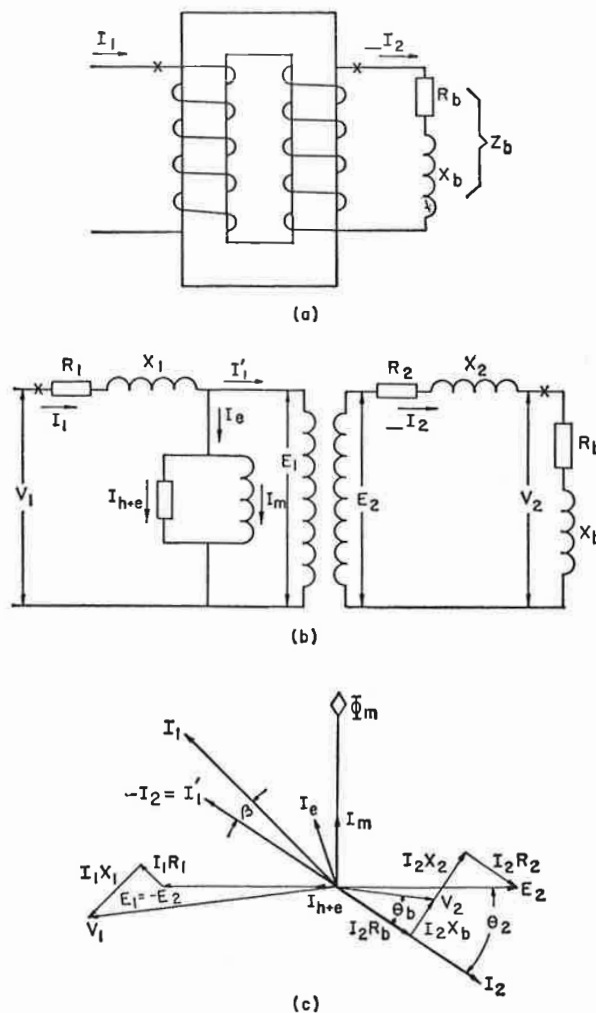

Fig. 51—(a) Circuit of an Instrument Current Transformer, (b) An Equivalent circuit of an instrument current transformer, (c) Vector diagram of (a) and (b).

a current transformer, the primary current is determined by the load being metered and is not influenced by the transformer or its burden; the flux density and exciting current are variable and are determined by the secondary circuit impedance and primary current. The vector diagram is restricted to fundamental frequency components and does not include any harmonics. This factor should be recognized in analyzing the operation of the current transformer in the regions of non-linearity.

Due to the phase relationships which exist between other quantities and the induced voltage, E_2 , it is convenient to take E_2 as the reference vector. The mutual flux is in leading quadrature and proportional to E_2 . The exciting current, I_e , is made up of the power component, I_{h+e} , in leading quadrature with ϕ , and the magnetizing component, I_m , in phase with ϕ . The demagnetizing effect of the secondary current, I_2 , must be

balanced out by $\frac{N_2 I_2}{N_1} = I_1'$, the transformer load component of primary current, I_1 .

The primary current is determined by the primary load being metered and is independent of the transformer in its burden. However, the primary current is the sum of I_e and I_1' . The flux is variable and is determined by the induced voltage necessary to circulate I_2 through the total secondary impedance, $Z_b + Z_2$. Since ϕ is variable and the manners in which I_{h+e} and I_m vary with ϕ are different, the required E_2 and ϕ have direct bearings on the magnitude and phase angle of I_e . The magnitude and phase angle of I_2 and I_e have direct influences on the relative magnitudes and phase angle of I_1 and I_1' . This is the only characteristic which is of direct importance. The angle, β , by which I_1' leads I_1 is the phase angle of the transformer for that particular burden and saturation. The ratio, I_1/I_2 , is the ratio of the transformer for a particular burden and saturation. If it were not for the exciting current, the total primary ampere-turns would exactly balance out the secondary ampere-turns. No phase displacement between primary and secondary currents would exist and the ratio of I_1/I_2 would be equal to exactly the turns ratio.

For a qualitative analysis of a current transformer, it is necessary to consider the variations in magnitude of I_{h+e} and I_m with ϕ , and the relation of both components to I_2 in magnitude and phase. In order to minimize I_e , the current transformer is designed to be operated at a low flux density of the order of one kilogauss. In this region, the permeability is much lower than the maximum effective permeability. The ratio of I_m to ϕ , E_2 , or I_2 for a given burden decreases for increases in ϕ , E_2 , or I_2 . In the same region, I_{h+e} is approximately proportional to ϕ , E_2 , or I_2 for a fixed burden. For a fixed burden, I_{h+e} is proportional to I_2 , and I_m increases at a lesser rate than I_2 . Therefore, as I_2 increases, I_e increases at a lesser rate and leads ϕ by a greater angle.

The magnitude and power factor of the transformer burden have pronounced effects on the ratio and phase angle of a current transformer. For high power factor burdens, the principal influence on the ratio error is I_{h+e} , but the principal influence on phase angle is I_m .

An increase in line current has less effect on the ratio error than it has on the phase angle. However, the phase angle decreases for increases in line current. For low power factor burdens, the principal influence on the per cent ratio error is I_m , but the principal influence on phase angle is I_{h+c} . Since I_m does not increase as rapidly as I_1 or I_2 , the decrease in per cent ratio error with line current is slightly greater for low power factor burdens than it is for high power factor burdens. Also, the change in phase angle with I_1 or I_2 is slightly greater for high power factor burdens. For a given magnitude of Z_b and I_1 or I_2 , the ratio error increases for decreases in burden power factor, reaches a maximum when I_o and I_1 are in phase, and decreases for further reductions in burden power factor. The phase angle decreases as the burden power factor decreases, becomes zero when I_o and I_1 are in-phase, and becomes negative for further decreases in burden power factor. The per cent ratio error and phase angle are greater at high burdens and low line currents, since I_o then represents a large portion of the line current.

For a typical condition, the burden power factor may be of the order of 35 to 65 per cent. In the absence of compensation, the ratio would be greater than $\frac{N_2}{N_1}$ throughout the range of load currents, and decreasing at a decreasing rate. Since the turns

ratio $\frac{N_2}{N_1}$ is at the designer's selection, the designer usually compensates the transformer by choosing $\frac{N_2}{N_1}$ less than the desired ratio, such that at about 60 per cent of rated line current, the ratio error is zero.

Errors in Instrument Current Transformers—As has been discussed in the preceding section, the current transformers are subject to ratio errors and a phase angle between primary and secondary values.

The ratio correction factor (*RCF*) of a current transformer is that factor by which the marked ratio (ratio indicated on the nameplate) must be multiplied to obtain the true ratio I_1/I_2 . The *RCF* of a current transformer is given by Equation 43.

$$RCF = \frac{I_1/I_2}{\text{Marked Ratio}} \quad (43)$$

The phase angle (β) of a current transformer is the angle between the current leaving the identified secondary terminal and the current entering the identified primary terminal. The phase angle (β) is considered positive if the secondary current leaving the marked terminal leads the primary current entering the marked terminal.

The phase angle correction factor (*PACF*) of a current transformer, like the *PACF* of a potential transformer, is that factor by which the indicated system power factor on the secondary side of a current transformer must be multiplied to obtain the true system power factor of the load being measured. The *PACF* of a current transformer is given by

$$PACF = K_\beta = \frac{\cos \theta_p}{\cos \theta_s} \quad (a)$$

$$K_\beta = \frac{\cos (\theta_s + \beta)}{\cos \theta_s} \quad (b) \quad (44)$$

$$K_\beta = \frac{\cos \theta_p}{\cos (\theta_p - \beta)} \quad (c)$$

where

θ_p = true system power factor angle

θ_s = apparent system lagging power factor angle

β = current transformer phase angle, minutes

By following a development similar to that used in the analysis of potential transformers, an approximate expression for the *PACF* is reached. The approximate expression for *PACF* is given by Equation 45

$$PACF = K_\beta \approx (1 - \frac{\beta \tan \theta_s}{3438}) \quad (a) \quad (45)$$

$$K_\beta \approx (1 - \frac{\beta \tan \theta_p}{3438}) \quad (b)$$

Like the transformer correction factor for a potential transformer, the transformer correction factor for a current transformer is the product of (*PACF*) and (*RCF*) and is given by Equation 46

$$TCF = (RCF) (PACF) = (RCF) K_\beta \quad (a) \quad (46)$$

$$TCF \approx (RCF) [1 - \frac{\beta \tan \theta_p}{3438}] \quad (b)$$

Table 10—Standard Primary-Current Rating and Standard Ratios for Current Transformers*

(a) Single-Ratio Current Transformers

Standard-Primary-Current Rating	Standard Ratio	Standard Primary-Current Rating	Standard Ratio	Standard Primary-Current Rating	Standard Ratio
10	2:1	100	20:1	800	160:1
15	3:1	150	30:1	1200	240:1
25	5:1	200	40:1	1500	300:1
40	8:1	300	60:1	2000	400:1
50	10:1	400	80:1	3000	600:1
75	15:1	600	120:1	4000	800:1

(b) Double-Ratio Current Transformers

Standard Primary-Current Rating	Standard Ratio	Standard Primary-Current Rating	Standard Ratio
25/50	5/10:1	200/400	40/80:1
50/100	10/20:1	400/800	80/160:1
100/200	20/40:1	600/1200	120/240:1

(c) Multiratio Transformers (Bushing Type)

Standard Primary-Current Rating Maximum	Standard Ratios
600	120/80/60/40/20:1
1200	240/160/120/80/40:1
2000	400/300/240/160:1
3000	600/400/300:1
4000	800/600/400:1

*ASA Standard C57.13—1954, Instrument Transformers.

Table 11—Standard Burdens for Standard 5-Ampere Secondary-Current Transformers*

Designation of Burden	Standard Burden Characteristics		Standard Secondary-Burden Impedance Ohms and Power Factor and Standard Secondary Volt-Ampere Burdens					
	Resistance Ohms	Inductance Milli-henrys	For 60-Cycle and 5-Ampere Secondary Current			For 25-Cycle and 5-Ampere Secondary Current		
			Impedance Ohms	Volt Amperes	Power Factor	Impedance Ohms	Volt-Amperes	Power Factor
B-0.1	0.09	0.116	0.1	2.5	0.9	0.0918	2.3	0.98
B-0.2	0.18	0.232	0.2	5.0	0.9	0.1836	4.6	0.98
B-0.5	0.45	0.580	0.5	12.5	0.9	0.4590	11.5	0.98
B-1	0.5	2.3	1.0	25	0.5	0.617	15.4	0.81
B-2	1.0	4.6	2.0	50	0.5	1.234	30.8	0.81
B-4	2.0	9.2	4.0	100	0.5	2.468	61.6	0.81
B-8	4.0	18.4	8.0	200	0.5	4.936	123.2	0.81

*ASA Standard C57.13—1954, Instrument Transformers.

In general, the accuracy of a current transformer depends upon the transformer burden, transformer secondary winding impedance, degree of saturation of the core, and the magnetic properties of the core. Standards of accuracy classification of standard burdens have been established for rating a current transformer with regard to accuracy when operated at rated current and frequency. Due to the differences in accuracy requirements for metering and relaying, current transformer accuracy standards have been established for metering and relaying applications.

Ratings of Current Transformers—The definition of an instrument current transformer in terms of its rating includes: 1) primary and secondary currents; 2) ambient; 3) continuous thermal-current rating factor; 4) insulation class; 5) impulse level in terms of full-wave test voltage; 6) frequency; 7) standard accuracy-class at specified standard burden, current, and frequency; and 8) short-time thermal and short-time mechanical current rating.

Standard primary-current rating, and standard ratios for current transformers are shown in Tables 10(a), (b), and (c). The primary current rating of current trans-

formers should be the lowest standard primary current rating which is equal to or greater than the full load current of the circuit or apparatus to which it is applied.

Standard burdens for 5-ampere secondary, 60 and 25 cycles standard current transformers are expressed in resistance, inductance, impedance, volt-amperes, and power factor. Expressing the burden in terms of impedance rather than in volt-amperes is preferable. The volt-ampere burden is that burden imposed by an impedance Z at rated secondary current or is I^2Z . Standard burdens are shown in Table 11. Standard burdens for metering service are B-0.1, B-0.2 and B-0.5, which are impedances of 90 per cent power factor at 60 cycles of 0.1, 0.2, and 0.5 ohms, respectively. Standard burdens for relaying service are B-1, B-2, B-4, and B-8 which are impedances at 50 per cent power factor at 60 cycles of 1, 2, 4, and 8 ohms, respectively. Standard burdens at all frequencies have the same value of resistance and inductance as shown in Table 11.

Both ratio errors and phase angles may be of importance for metering service. However, such a high degree of accuracy is not required or practicable for relaying

Table 12—Standard Accuracy Classes and Corresponding Limits of Transformer Correction Factors for Current Transformers for Metering Service*

Accuracy Class	Limits of Transformer Correction Factor				Limits of Power Factor (Lagging) of Metered Power Load
	100-Percent Rated Current		10-Percent Rated Current		
	Minimum	Maximum	Minimum	Maximum	
1.2	0.988	1.012	0.976	1.024	0.6-1.0
0.6	0.994	1.006	0.988	1.012	0.6-1.0
0.3	0.997	1.003	0.994	1.006	0.6-1.0
0.5	0.995†	1.005†	0.995	1.005	0.6-1.0

†These values also apply to 150-percent rated current.

*ASA Standard C57.13—1954, Instrument Transformers.

service; therefore, the ratio error, usually being the error of particular interest, is the prime consideration in accuracy classifications for relaying service.

Standard accuracy classes for current transformers and corresponding limits of transformer correction factor (*TCF*) for metering service are shown in Table 12. The true system power factor θ_p is assumed to range from .6 lagging to unity. The standards take into account the effect of phase angle by allowing a larger phase angle when the ratio in error is such that a larger phase angle error may be tolerated to yield the same transformer correction factor. The relationship between

the limits of ratio correction factor and phase angles for limiting values of transformer correction factors given in Table 12 are shown in Fig. 52. The *TCF* is given by Equation 46.

$$TCF = (RCF) (PACF) = (RCF) K_{\beta} \quad (a)$$

$$TCF \approx RCF \left(1 - \frac{\beta \tan \theta_p}{3438}\right) \quad (b) \quad (46)$$

where

$$\beta = \text{phase angle in minutes}$$

The accuracy standards apply for all currents from 10 per cent to 100 per cent rated. Therefore, the *RCF* and β shall be within the outer and inner parallelograms at 100 and 10 per cent rated current, respectively. Since *RCF* is approximately unity, for any known *RCF*, the positive and negative limiting values of β in minutes can be adequately expressed by Equation 47.

$$\beta = 2600 (RCF - TCF) \quad (47)$$

The parallelograms are based on this expression rather than the more accurate expression of Equation 44(c). The limits of *RCF* and β are obtained by applying the limits of system power factor to Equation 44(c). Therefore, application of a system power factor of 60 per cent in Equation 44(c) results in Equation 48.

$$\cos(53.13^\circ - \beta) = .6 \frac{RCF}{TCF} \quad (48)$$

27. Final Instrument Transformer Correction Factor

In metering applications involving both potential and current transformers, the apparent power or energy as indicated or registered on a wattmeter or watthour meter must be multiplied by the final transformer correction factor to give the true power or energy. The

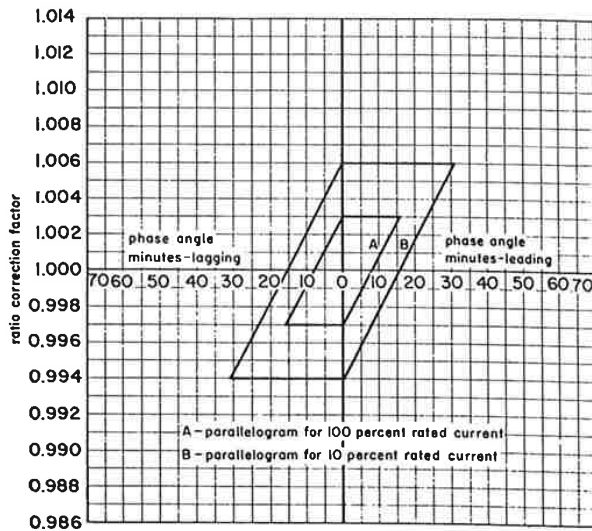

figure 3: Accuracy class 0.3

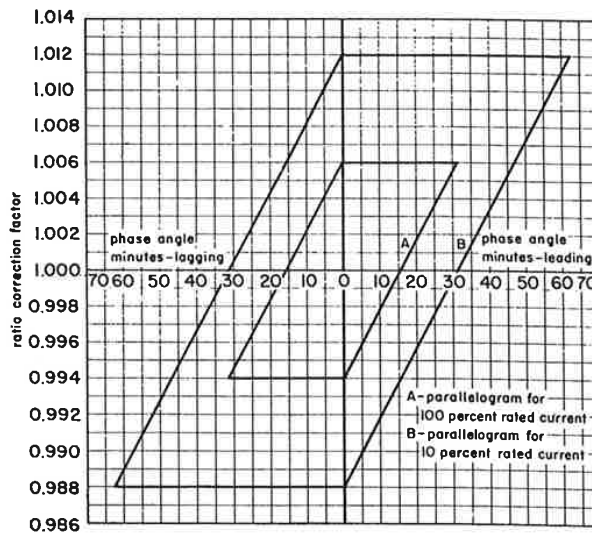

figure 4: Accuracy class 0.6

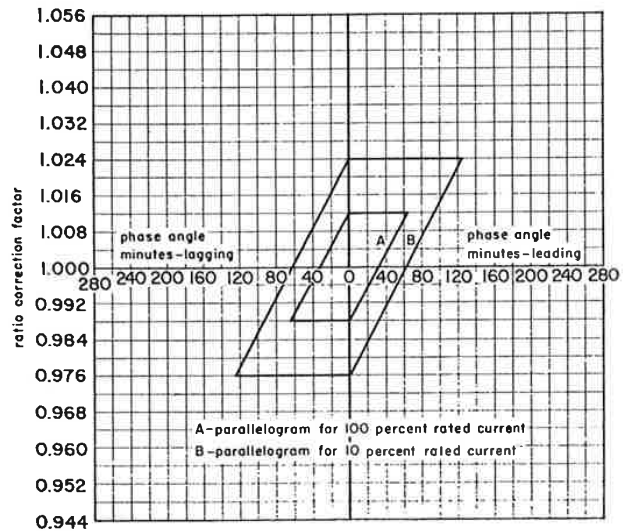

figure 5: Accuracy class 1.2

Fig. 52—Limits of ratio correction factor and phase-angle for standard accuracy classes for current transformers for metering service.

final transformer correction factor is the product of the potential and current transformer ratio correction factors and the combined phase angle correction factor, K_o . Correction must be made for the combined effects of the phase angle of the wattmeter potential circuit and the potential and current transformers, α , γ , and β respectively. In watthour meter applications, no meter potential circuit phase angle is involved and α is zero. The instrument transformer ratio correction factors have been discussed and require no further remarks. However, the combined phase-angle correction factor requires special consideration.

The combined phase angle correction factor is the factor by which the apparent (indicated by the meter) power factor must be multiplied to obtain the true power factor. The true or primary lagging power factor angle is greater than the apparent lagging power factor angle by $(-\alpha + \beta - \gamma)$. As with the ($PACF$) for the individual transformers, the combined ($PACF$) is given by Equation 49.

In the Master Test Code for Electrical Measurements in Power Circuits and the American Standard Code for Electricity Meters, the $PACF$ is expressed in terms of θ_a , the apparent power factor of the load as measured on the secondary sides of the transformers involved.

$$PACF = K_o = \frac{\cos \theta}{\cos \theta_2} \tag{a}$$

$$= \frac{\cos (\theta_2 - \alpha + \beta - \gamma)}{\cos \theta_2} \tag{b} \tag{49}$$

$$\approx 1 - \frac{(-\alpha + \beta - \gamma) \tan \theta_a}{3438} \tag{c}$$

where

α, β, γ = phase angle of meter potential circuit, current transformer, and potential transformers, respectively in minutes

θ = true system power factor

θ_a = apparent (indicated) system power factor angle

The notations θ and θ_2 of Equation 49 correspond with θ_p , the true system power factor angle, and θ_a , the apparent or indicated system power factor angle, respectively, which have been adopted elsewhere in this chapter. The expressions given in Equations 49(a) and 49(b) are as given in the Master Test Code and the American Standard Code; however, in the American Standard Code, α , the phase angle of the meter potential circuit is not included, since that code applies to watthour meters only.

The instrument transformer final correction factor is given by

Table 13—Standard Insulation Classes and Standard Dielectric Tests for Current Transformers**

Standard Insulation Class (Name-Plate Rating)	Maximum Line-to-Line Voltage	Standard Dielectric Tests			
		Standard Low-Frequency Tests	Standard Impulse Tests		Full Wave
			Chopped Wave		
			Crest Voltage	Minimum Time to Flashover	
Col. 1	Col. 2	Col. 3	Col. 4	Col. 5	Col. 6
Kv	Kv	Kv Rms	Kv Crest	μ Second	Kv Crest
0.6	0.6	4	12	1.0	10
1.2	1.2	10	36	1.0	30
2.5	2.5	15	54	1.25	45
5.0	5.0	19	69	1.5	60
8.7	8.66	26	88	1.6	75
15 L	15	34	110	1.8	95
15 H	15	34	130	2.0	110
25	25	50	175	3.0	150
34.5	34.5	70	230	3.0	200
46	46	95	290	3.0	250
69	69	140	400	3.0	350
92*	92	185	520	3.0	450
115	115	230	630	3.0	550
138	138	275	750	3.0	650
161	161	325	865	3.0	750
196*	196	395	1035	3.0	900
230	230	460	1210	3.0	1050
287*	287	575	1500	3.0	1300
345*	345	690	1785	3.0	1550

*These system voltages are not in the *EEI-NEMA Preferred Voltage Ratings for A-C Systems and Equipment* report (EEI R-6, NEMA 117).
 **ASA Standard C57.13—1954, Instrument Transformers.

where $(TCF)_t = (RCF)_p (RCF)_i K_c$ (50)

$(RCF)_p, (RCF)_i$ = ratio correction factors of potential and current transformers, respectively.

K_c = phase angle correction factor

$$K_c \approx 1 - \frac{(-\alpha + \beta - \gamma) \tan \theta_s}{3438}$$

Since each of the correction factors are usually very near unity, the $(TCF)_t$ is given with sufficient accuracy by

$$(TCF)_t \approx (RCF)_p + (RCF)_i + (K_c) - 2 \quad (51)$$

28. Insulation Requirements for Instrument Transformers

Modern lines of instrument transformers are rated at definite impulse voltage levels and are given low frequency dielectric tests in line with ASA Standard C-57. However, the insulation class must be coordinated with system connections to avoid dielectric stresses that may result in reduced life expectancy, radio interference, and corona. The manner in which standard insulation class is coordinated with typical system voltages and power transformer connections should be of prime importance in the selection of instrument transformers.

Standard Insulation Classes, Standard Marked Ratios, Standard Primary-Voltage Ratings and Standard Dielectric Tests for Potential Transformers are shown in Table 7. Typical Primary Connections for Potential Transformers which correspond with the groups of Table 7 are shown in Fig. 49. Standard Insulation Classes and Standard Dielectric Tests for Current Transformers are shown in Table 13.

Transformers shown in Table 7 are segregated into three groups of potential transformers designed for specific connections. Transformers in group 1 are designed for operation line-to-line, line-to-neutral, or line-to-ground. Those in group 2 are designed for operation for line-to-line only. Those in group 3 are three-winding transformers, and are designed for connection between line and ground only.

Comparison of standard insulation class and circuit voltages in Table 7 and maximum line-to-line voltage in Table 13 shows that the insulation class in kv to always be greater than the circuit voltage. The circuit voltage in Table 7 is the maximum line-to-line, three-phase voltage. These tables indicate that the maximum continuous operating voltage-to-ground should not exceed the $\frac{\text{insulation class voltage}}{\sqrt{3}}$. Clarification of this rule is discussed in detail with examples in reference 42.

Application of current transformers and potential transformers to some typical system voltages and connections is shown in Table 14. It is by no means complete, but it covers most major applications from 600 volts to 24,000 volts. The table is not extended beyond 24,000 volts, since the examples seem to be typical of the entire range. However, lines 6, 22, and 27 are worthy of further mention, because such are special applications for potential transformers. Potential transformers in these applications are principally for ground

fault detection. In case of ground fault, the voltage across the transformer on the faulted phase collapses, and the other two transformers swing into open delta from line-to-line, and have the applied voltages increase by $\sqrt{3}$. The potential transformers on lines 6 and 22 are normally applied at reduced voltage, while the transformer in line 27 is a standard design operating at low enough induction to operate continuously at $\sqrt{3}$ times normal voltage.

If a transformer is operated at excessive voltage-to-ground, failure of the transformer may result in either of two ways: 1) by destruction of the insulation due to corona or dielectric heating; and 2) by lightning. Although the lightning arresters may adequately protect other insulation on a part of the system, they may offer inadequate protection for a transformer in a standard insulation class less than that applied on other related apparatus.

Application of current transformers in the neutral of grounded wye-connected transformers justify special consideration, because reduced insulation may be applicable in the neutral transformer. Minimum Insulation Class for current transformers in the neutral grounding connection is shown in Table 15. Full insulation is required on applications in which the standard insulation class of the line is less than 15 kv.

29. General Application Data for Instrument Transformers

Much of the data required for application of instrument transformers has been discussed in connection with the transformer ratings and insulation requirements. Most of the rating data is also general application data. However, the accuracy standards are for rating purposes only and may not be suitable for practical metering application. Also, other topics such as operating limitations, determination of burdens, and polarity identification are of prime importance in applications of instrument transformers.

Accuracies of Instrument Transformers in Metering Applications—The standards burdens and accuracy rating standards of instrument transformers are for rating purposes only. In metering applications, the established tolerances in metering apply equally well to metering involving instrument transformers and self-contained metering. The tolerances include the instrument transformer errors. In calibration of transformer rated meter applications, the watt-hour meter is calibrated for application with the particular instrument transformer with which it is used. The meter is calibrated at the tests normally given self-contained meters. The final instrument transformer correction factors for the test conditions are determined first. Using the transformer correction factors as a reference, the watt-hour meter is calibrated so that the overall accuracy of the meter and instrument transformers is within the required tolerance.

Accuracy certificates for a particular instrument transformer at the standard burdens are available from the manufacturer. Typical characteristics are shown in Fig. 53. The variation in accuracy characteristics with burden and burden power factor can be evaluated from

Table 14—Application of Potential and Current Transformers to Some Typical Operating Circuit Voltages

Line No.	System Line-to-Line Voltage	Circuit Connections: see Figure:	ASA Insulation Class and FWI Levels Required by Circuit		Current Transformers: Kv Class	Application of Standard Instrument Transformer to Circuit as Indicated	
			Kv Class (1)	Impulse Levels Full Wave: Kv		Potential Transformers	
						Rating	Type of Application for Metering or Relaying
<p>(1) The standard insulation class in kv is not the maximum continuous operating voltage to ground; this value is $\frac{\text{maximum continuous operating voltage to ground}}{\sqrt{3}}$ = maximum continuous operating voltage to ground. Operation in excess of this value is limited by dielectric over-stress of the insulation which may result in corona, radio influence and deterioration of insulation. Usually it is permissible, considering the above factors, to operate a system under emergency conditions for periods of time without failure but with some sacrifice in life expectancy.</p> <p>example: A 24,000-volt, 3-phase, 3-wire ungrounded system on which one phase may become grounded.</p> <p>(2) In this application, since the transformer is designed for application in wye, this circuit could be operated with any corner of the delta permanently grounded without any sacrifice in life expectancy of these transformers, though other apparatus on the system might be affected by such operation.</p> <p>(3) Special transformer.</p> <p>(4) In this application, the transformers are not good for operation in wye; therefore, note (2) does not apply, but note (1) does.</p> <p>(5) These applications and similar applications to other circuits are for ground fault detection. Normal operation is at reduced induction (voltage); however, a phase fault to ground places $\sqrt{3}$ times greater voltage and dielectric stress on the two voltage transformers on the unfaulted phases. Since the transformers under fault condition to the ground are operating at normal voltage, the application is satisfactory; however, the insulation to ground is over-stressed for continuous operation. See note (9) (b).</p> <p>(6) This is a common single-phase application to rural single-phase lines or railway lines where one side of the circuit is grounded. If one side of the circuit were not grounded, the next lower class of insulation could be used.</p> <p>(7) This unit is over-insulated but is a stock rating that would be applied normally.</p> <p>(8) This is a special design with 25-kv class insulation.</p> <p>(9) Note that in this application: (a) transformers of standard design may be used; they are designed to operate on an emergency basis with $\sqrt{3}$ times normal voltage across the terminals; (b) the insulation class is not increased, which indicates this is not a continuous operating condition. Note the applications in lines 6 and 22 are similar applications using standard transformers with reduced voltage across the winding.</p>							
1	600	(a)	1.2	30	1.2	600/1040 Y	in delta (2)
2	600	(c)	1.2	30	1.2	600/1040 Y	line to grd.
3	1040	(b)	1.2	30	1.2	600/1040 Y	line to neutral
4	1040	(b)	1.2	30	1.2	1040/1040 Y	in delta (3)
5	2400	(a)	2.5	45	2.5	2400/2400 Y	in delta (4)
6	2400	(a)	2.5	45	2.5	2400/2400 Y	in wye to grd. (5)
7	2400	(c)	5.0	60	5.0	2400/4160 Y	line to grd. (6)
8	4160	(a)	5.0	60	5.0	4800/4800 Y or 4200/7280 Y (7)	in delta (4)
9							in delta
10	4800	(a)	5.0	60	5.0	4800/4800 Y or 4800/8320 Y (7)	in delta (4)
11							in delta
12	4160	(b)	5.0	60	5.0	2400/4160 Y	line to neutral
13	4160	(b)	5.0	60	5.0	same as lines 8 and 9	lines 8 and 9
14	4800	(b)	5.0	60	5.0	same as lines 10 and 11	lines 10 and 11
15	4800	(c)	8.7	75	8.7	4800/8320 Y	line to grd. (6)
16	7200	(a)	8.7	75	8.7	7200/7200 Y or 7200/12470 Y (7)	in delta (4)
17							in delta
18	7200	(b)	8.7	75	8.7	4200/7280 Y	in wye
19	7200	(b)	8.7	75	8.7	7200/7200 Y	in delta (4)
20	7200	(c)	15	95 or 110	15	7200/12470 Y	line to grd. (6)
21	12000	(a)	15	95 or 110	15	12000/12000 Y	in delta (4)
22	12000	(a)	15	95 or 110	15	12000/12000 Y	in wye to grd. (5)
23	12000	(b)	15	95 or 110	15	12000/12000 Y	in delta (4)
24	12000	(b)	15	95 or 100	15	7200/12470 Y	in wye
25	12000	(c)	25	150	25	12000/20800 Y (8)	line to grd. (6)
26	24000	(a)	25	150	25	24000/24000 Y	in delta (4)
27	24000	(a)	25	150	25	14400 for 25000 grd. Y	in wye, line to grd. for relaying grd. fault on an ungrounded system (9)
28	24000	(b)	25	150	25	24000/240000 Y	in delta

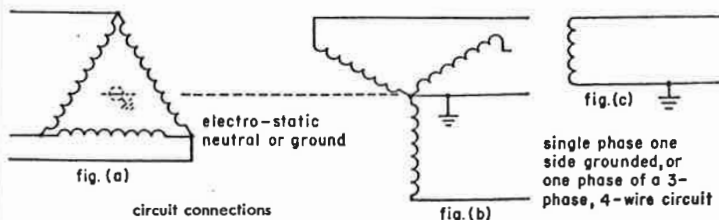

the accuracy certificates. The variation in the RCF and phase angle with burden and burden power factor may be so small as to be constant. Also, the errors might be negligible. Also, the particular burden may be sufficiently close to a standard burden that the accuracy under the particular burden may be estimated with sufficient accuracy. However, determining the accuracies of a particular burden may be necessary. Since the ratio correction factor (RCF) and phase angle, γ , of potential transformers for a specific burden are linear functions of burden, the characteristics at a particular burden can be determined from the characteristics at a standard burden. However, such is not the case with current transformers. The characteristics of a current transformer at a particular burden and current require

certain tests on the transformer. The potential transformer is considered first. Having determined the particular burden imposed on the potential transformer, the (RCF) and phase angle can be determined from Equation 50.

$$R_x = R_b \cos(\theta_b - \theta_x) + \frac{P_b}{3438} \sin(\theta_b - \theta_x) \quad (a)$$

$$P_x = P_b \cos(\theta_b - \theta_x) - 3438 R_b \sin(\theta_b - \theta_x) \quad (b)$$

where

R_x = the change in ratio error from zero to 100 per cent secondary burden at the new burden power factor, per unit.

P_x = the change in phase angle from zero to 100 per cent secondary burden at the new burden power factor, minutes.

θ_x = lagging power factor angle of new burden. (The sign of θ_x is "+" for lagging power factor burdens.)

R_b = the change in ratio error from zero to 100 per cent secondary burden at the power factor for which the characteristics are given on typical curves, per unit.

P_b = the change in phase angle from zero to 100 per cent secondary burden at the power factor for which the characteristics are given on typical curves, minutes.

θ_b = lagging power factor angle for burdens represented in typical characteristics curves. (The sign of θ_b is "+" for lagging power factor burdens.)

The errors present in a transformer at no load are due to the exciting current drawn. Therefore, all RCF vs. per cent secondary burden curves for all power factors pass through the same point at zero burden. Also, all phase angle vs. per cent secondary burden curves for all power factors pass through the same point at zero burden.

Since the ratio correction factor and phase angle characteristics of a current transformer are not linear, it is not practical to determine these characteristics at a particular burden from the known characteristics at a standard burden. Determining the characteristics for a current transformer requires tests on the transformer

at the particular burden.^{43, 44} Various methods are applicable to calibrating current transformers; however, most methods require special equipment. A simple method for determining the ratio error and phase angle of a current transformer is discussed in reference 43. This method requires determining the open-circuit voltage as a function of the components of exciting current, the transformer secondary leakage reactance and resistance, and the exact turns ratio. The characteristics derived by this method agree reasonably well for metering purposes with characteristics determined from more expensive tests.

Correction Factors—Phase-angle, (*PACF*), ratio (*RCF*), and transformer (*TCF*) are discussed at length under "Errors . . ." for both potential and current transformers. The discussions are summarized here for reference purposes, in the applications of instrument transformers.

Ratio Correction Factor (*RCF*)

$$\text{for } PT\text{'s } (RCF)_p = \frac{V_1/V_2}{\text{Marked Ratio}} \tag{38}$$

$$\text{for } CT\text{'s } (RCF)_I = \frac{I_1/I_o}{\text{Marked Ratio}} \tag{43}$$

Phase-Angle Correction Factor, (*PACF*)

$$\text{for } PT\text{'s } (PACF)_p = K_\gamma \approx \left(1 + \frac{\gamma \tan \theta_s}{3438} \right) \tag{40a}$$

$$K_\gamma \approx \left(1 + \frac{\gamma \tan \theta_p}{3438} \right) \tag{40b}$$

$$\text{for } CT\text{'s } (PACF)_I = K_\beta \approx \left(1 - \frac{\beta \tan \theta_s}{3438} \right) \tag{45a}$$

$$K_\beta \approx \left(1 - \frac{\beta \tan \theta_p}{3438} \right) \tag{45b}$$

for both *PT*'s, *CT*'s and instrument combined

$$PACF = K_c \approx 1 - \frac{(-\alpha + \beta - \gamma)}{3438} \tan \theta_s \tag{49}$$

where α = phase angle of instrument potential circuit Transformer Correction Factors (*TCF*)

$$\text{for } PT\text{'s } (TCF)_p = (RCF)_p K_\gamma \approx (RCF)_p \left(1 + \frac{\gamma \tan \theta_s}{3438} \right) \tag{41d}$$

$$\approx (RCF)_p \left(1 + \frac{\gamma \tan \theta_p}{3438} \right) \tag{41e}$$

$$\text{for } CT\text{'s } (TCF)_I = (RCF)_I K_\beta \approx (RCF)_I \left(1 - \frac{\beta \tan \theta_s}{3438} \right) \tag{45a}$$

$$\approx (RCF)_I \left(1 - \frac{\beta \tan \theta_p}{3438} \right) \tag{45b}$$

Final (*TCF*)_t, combined *PT*'s and *CT*'s

$$(TCF)_t = (RCF)_p (RCF)_I K_c \tag{50}$$

$$\text{or } (TCF)_t \approx (RCF)_p + (RCF)_I + K_c - 2 \tag{51}$$

where γ , β = phase-angle, minutes of *PT* and *CT*, respectively

θ_s = apparent (indicated) lagging load power-factor angle.

Table 15—Minimum Insulation Class for Current Transformers in the Neutral Grounding Connection*

Winding Insulation Class at Line End	Minimum Insulation Class	
	Grounded Solidly or Through Current Transformer	
Col. 1	Col. 2	
Kv	Kv	
1.2	} Same as line end	
2.5		
5.0		
8.66		
15		8.66
25		8.66
34.5		8.66
46		15
69		15
92		15
115		15
138		15
161		15
196		15
230		15
287		15
345		15

*ASA Standard C57.13—1954, Instrument Transformers.

Instrument transformer phase-angle correction factors are given in Table 16 for various phase-angles $(-\alpha + \beta - \gamma)$ and apparent load power-factors, where α is the phase angle of the instrument potential circuit. For only PT's or CT's, consider only the phase angle of the transformer involved; consider the phase angle of the transformer or instrument not involved as zero. For watt-hour meters, α is zero. Transformer correction factors for PT's and CT's are shown in Tables 17(a) and 17(b), respectively.⁴⁰ Table 17(b) is also applicable to the final $(TCF)_t$ if the RCF is equal to either $[(RCF)_p \times (RCF)_t]$ or $[(RCF)_p + (RCF)_t - 1]$ and β which is shown is considered as $(\beta - \gamma)$.

Determining PT Burden The burden on a potential transformer is the total load on the transformer. If the effects of the secondary leads are neglected, the burden on potential transformer is composed of instruments or relays in parallel. Additional burdens are added in parallel. The resulting total burden is most easily calculated by determining the total watts burden and total reactive volt-amperes burden separately, and then determining the resultant burden in volt-amperes by Equation 52.

$$\begin{aligned} \text{total burden (volt-amperes)} & \quad (a) \\ & = \sqrt{(\text{total watts})^2 + (\text{total reactive volt-amperes})^2} \\ \text{power factor of burden} & \quad (52) \\ & = \frac{\text{total watts}}{\text{total burden (volt-amperes)}} \quad (b) \end{aligned}$$

By referring to typical ratio and phase angle curves supplied by the manufacturer for the transformer in question, the performance at the above burden may be determined.

However, if the instruments are located a considerable distance from the transformer, the secondary leads may have sufficient impedance to introduce an additional voltage drop and phase shift in the voltage. If the impedance of the secondary leads are in series with the circuit which is composed of instruments in parallel and the resistance of the secondary leads is greater than .0005 times the resistance of the watt element of the

total instrument burden $(R = \frac{E^2}{\text{watts}})$, the additional per cent ratio and phase angle applicable to a typical curve should be calculated from application of Equation 53.

$$\text{Increase in per cent ratio} = \frac{I_s(R_L \cos \theta + X_L \sin \theta)}{E_s} \times 100 \quad (a)$$

$$(53)$$

$$\text{Increase in phase angle} = \frac{I_s(R_L \sin \theta - X_L \cos \theta)}{E_s} \times 3438 \text{ minutes} \quad (b)$$

Where

- θ = total burden power factor angle
- R_L = resistance of secondary leads, ohms
- X_L = reactance of secondary lead, ohms
- I_s = potential transformer secondary current
- E_s = potential transformer secondary voltage

The increase in per cent ratio and phase angle, as determined from Equation 53 is added algebraically to

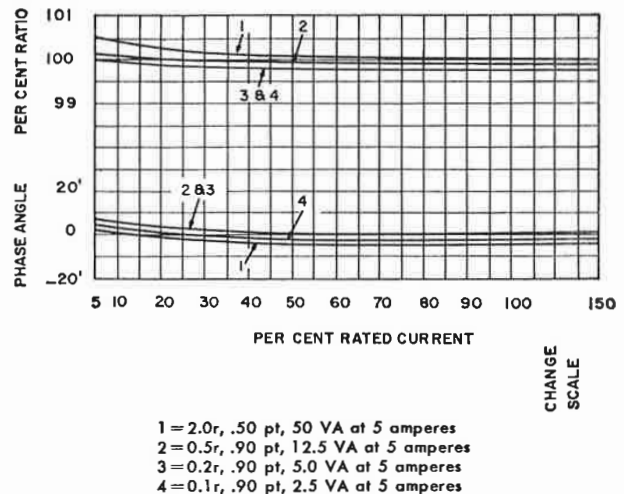
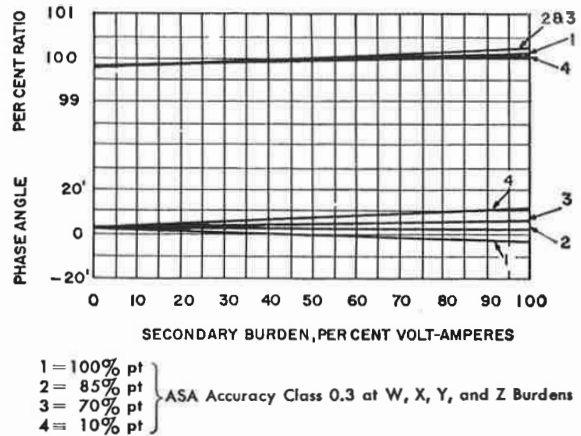

Fig. 53—Typical accuracy characteristics from accuracy certificates of instrument transformers (a) Potential transformer, (b) Current transformer.

the respective potential transformer calibration curves to get the actual per cent ratio of primary to burden voltage and the actual phase difference between primary and burden voltages.

The single-phase burdens imposed on potential transformers by typical instruments and meters are shown in Table 18. The devices included in Table 18 are supplied by Westinghouse, but the values are representative for each particular type of device. Where a high degree of accuracy is required, the actual burden imposed by the particular device must be considered.

Polyphase connections are so varied that it is difficult to give specific instructions for calculation of polyphase burdens. Generally, the procedure will be to calculate the phase position and magnitude of the current in each transformer and determine what equivalent single-phase burden would require the same current. The performance is then determined for the equivalent single-phase burden which would require the same current.

Table 16(a)—Instrument Transformer

CORRECTION FACTORS $\left(\frac{\cos \theta}{\cos \theta_2}\right)$ FOR PHASE ANGLESFor Lagging Current When $(-\alpha + \beta - \gamma)$ Is PositiveFor Leading Current When $(-\alpha + \beta - \gamma)$ Is Negative

Phase-angle $(-\alpha + \beta - \gamma)$	Apparent Power Factor $(\cos \theta_2)$ †													
	0.10	0.15	0.20	0.25	0.30	0.40	0.50	0.60	0.70	0.80	0.90	0.95	0.99	1.00
5'	0.9855	0.9904	0.9929	0.9944	0.9954	0.9967	0.9975	0.9981	0.9985	0.9989	0.9993	0.9995	0.9998	1.0000
10'	0.9711	0.9808	0.9857	0.9887	0.9907	0.9933	0.9950	0.9961	0.9970	0.9978	0.9986	0.9990	0.9996	1.0000
15'	0.9566	0.9712	0.9786	0.9831	0.9861	0.9900	0.9924	0.9942	0.9955	0.9967	0.9979	0.9986	0.9994	1.0000
20'	0.9421	0.9616	0.9715	0.9775	0.9815	0.9867	0.9899	0.9922	0.9940	0.9956	0.9972	0.9981	0.9992	1.0000
25'	0.9276	0.9520	0.9643	0.9718	0.9768	0.9833	0.9874	0.9903	0.9926	0.9945	0.9965	0.9976	0.9989	1.0000
30'	0.9131	0.9424	0.9572	0.9662	0.9722	0.9800	0.9848	0.9883	0.9911	0.9934	0.9957	0.9971	0.9987	1.0000
40'	0.8842	0.9232	0.9429	0.9549	0.9629	0.9733	0.9798	0.9844	0.9881	0.9912	0.9943	0.9961	0.9983	0.9999
50'	0.8552	0.9040	0.9286	0.9436	0.9536	0.9666	0.9747	0.9805	0.9851	0.9890	0.9929	0.9951	0.9978	0.9999
1° 0'	0.8262	0.8848	0.9143	0.9323	0.9444	0.9599	0.9696	0.9766	0.9820	0.9868	0.9914	0.9941	0.9974	0.9998
10'	0.7972	0.8656	0.9000	0.9209	0.9350	0.9531	0.9645	0.9726	0.9790	0.9845	0.9899	0.9931	0.9969	0.9998
20'	0.7682	0.8464	0.8857	0.9096	0.9257	0.9464	0.9594	0.9687	0.9760	0.9823	0.9885	0.9921	0.9964	0.9997
30'	0.7392	0.8271	0.8714	0.8983	0.9164	0.9397	0.9543	0.9648	0.9730	0.9800	0.9870	0.9911	0.9959	0.9997
40'	0.7102	0.8079	0.8571	0.8869	0.9071	0.9329	0.9492	0.9608	0.9699	0.9778	0.9855	0.9900	0.9954	0.9996
50'	0.6812	0.7886	0.8428	0.8756	0.8978	0.9262	0.9441	0.9568	0.9668	0.9755	0.9840	0.9890	0.9949	0.9995
2° 0'	0.6521	0.7694	0.8284	0.8642	0.8884	0.9194	0.9389	0.9529	0.9638	0.9732	0.9825	0.9879	0.9944	0.9994
10'	0.6231	0.7501	0.8141	0.8529	0.8791	0.9127	0.9338	0.9489	0.9607	0.9709	0.9810	0.9869	0.9939	0.9993
20'	0.5941	0.7308	0.7997	0.8415	0.8697	0.9059	0.9287	0.9449	0.9576	0.9686	0.9795	0.9858	0.9934	0.9992
30'	0.5650	0.7115	0.7854	0.8301	0.8603	0.8991	0.9235	0.9409	0.9545	0.9663	0.9779	0.9847	0.9928	0.9990
40'	0.5360	0.6923	0.7710	0.8187	0.8510	0.8923	0.9183	0.9369	0.9515	0.9640	0.9764	0.9836	0.9923	0.9989
50'	0.5069	0.6730	0.7566	0.8073	0.8416	0.8855	0.9132	0.9329	0.9483	0.9617	0.9748	0.9825	0.9917	0.9988
3° 0'	0.4779	0.6537	0.7422	0.7959	0.8322	0.8787	0.9080	0.9288	0.9452	0.9594	0.9733	0.9814	0.9912	0.9986
10'	0.4488	0.6344	0.7279	0.7845	0.8228	0.8719	0.9028	0.9248	0.9421	0.9570	0.9717	0.9803	0.9906	0.9985
20'	0.4198	0.6151	0.7135	0.7731	0.8134	0.8651	0.8976	0.9208	0.9390	0.9547	0.9701	0.9792	0.9900	0.9983
30'	0.3907	0.5957	0.6991	0.7617	0.8040	0.8583	0.8924	0.9167	0.9359	0.9523	0.9686	0.9781	0.9894	0.9981
40'	0.3616	0.5764	0.6847	0.7503	0.7946	0.8514	0.8872	0.9127	0.9327	0.9500	0.9670	0.9769	0.9888	0.9980
50'	0.3326	0.5571	0.6702	0.7388	0.7852	0.8446	0.8820	0.9086	0.9296	0.9476	0.9654	0.9758	0.9882	0.9978
4° 0'	0.3035	0.5378	0.6558	0.7274	0.7758	0.8377	0.8767	0.9046	0.9264	0.9452	0.9638	0.9746	0.9876	0.9976
10'	0.2744	0.5185	0.6414	0.7160	0.7663	0.8309	0.8715	0.9005	0.9232	0.9429	0.9622	0.9735	0.9870	0.9974
20'	0.2453	0.4991	0.6270	0.7045	0.7569	0.8240	0.8663	0.8964	0.9201	0.9405	0.9605	0.9723	0.9864	0.9971
30'	0.2163	0.4798	0.6125	0.6930	0.7474	0.8171	0.8610	0.8923	0.9169	0.9381	0.9589	0.9711	0.9857	0.9969
40'	0.1872	0.4604	0.5981	0.6816	0.7380	0.8103	0.8558	0.8882	0.9137	0.9357	0.9573	0.9699	0.9851	0.9967
50'	0.1581	0.4411	0.5837	0.6701	0.7285	0.8034	0.8505	0.8841	0.9105	0.9333	0.9556	0.9687	0.9844	0.9964
5° 0'	0.1290	0.4217	0.5692	0.6586	0.7191	0.7965	0.8452	0.8800	0.9073	0.9308	0.9540	0.9675	0.9838	0.9962
10'	0.0999	0.4024	0.5548	0.6472	0.7096	0.7896	0.8400	0.8759	0.9041	0.9284	0.9523	0.9663	0.9831	0.9959
20'	0.0708	0.3830	0.5403	0.6357	0.7001	0.7827	0.8347	0.8717	0.9008	0.9260	0.9507	0.9651	0.9824	0.9957

Interpolation for correction factors corresponding to values $(-\alpha + \beta - \gamma)$ lying between those given in the table, may be made without error. Interpolation for correction factors corresponding to values of $\cos \theta_2$ lying between those given in the table, may be made without exceeding an error of 0.0010 in the sections of the tables lying between the heavy black lines; outside of these sections, and in all cases where the adjacent values of $\cos \theta_2$ are separated by the heavy black lines the maximum error in interpolation will exceed 0.0010.

ACCORDING TO ASA STANDARDS:

α IS POSITIVE WHEN THE CURRENT IN THE WATTMETER POTENTIAL CIRCUIT LEADS THE VOLTAGE.

β IS POSITIVE WHEN THE SECONDARY CURRENT LEADS THE PRIMARY CURRENT.

γ IS POSITIVE WHEN THE SECONDARY VOLTAGE LEADS THE PRIMARY VOLTAGE.

† IN THE CASE OF POLYPHASE MEASUREMENTS, THE METER OR ELEMENT IN EACH PHASE MUST BE CORRECTED SEPARATELY, CONSIDERING θ AS THE ANGLE BETWEEN THE VOLTAGE AND CURRENT ON THE METER OR ELEMENT BEING CORRECTED (NOT THE ANGLE REPRESENTED BY THE POLYPHASE POWER FACTOR).

Table 16(b) Instrument Transformer

Correction Factors $\left(\frac{\cos \theta}{\cos \theta_2}\right)$ For Phase Angles
 For Lagging Current When $(-\alpha + \beta - \gamma)$ Is Negative
 For Leading Current When $(-\alpha + \beta - \gamma)$ Is Positive

Phase-angle ($-\alpha + \beta - \gamma$)	Apparent Power Factor ($\cos \theta_2$) †													
	0.10	0.15	0.20	0.25	0.30	0.40	0.50	0.60	0.70	0.80	0.90	0.95	0.99	1.00
5'	1.0145	1.0096	1.0071	1.0056	1.0046	1.0033	1.0025	1.0019	1.0015	1.0011	1.0007	1.0005	1.0002	1.0000
10'	1.0289	1.0192	1.0142	1.0113	1.0092	1.0067	1.0050	1.0039	1.0030	1.0022	1.0014	1.0010	1.0004	1.0000
15'	1.0434	1.0288	1.0214	1.0169	1.0139	1.0100	1.0075	1.0058	1.0044	1.0033	1.0021	1.0014	1.0006	1.0000
20'	1.0579	1.0383	1.0285	1.0225	1.0185	1.0133	1.0101	1.0077	1.0059	1.0043	1.0028	1.0019	1.0008	1.0000
25'	1.0723	1.0479	1.0356	1.0281	1.0231	1.0166	1.0126	1.0097	1.0074	1.0054	1.0035	1.0024	1.0010	1.0000
30'	1.0868	1.0575	1.0427	1.0338	1.0277	1.0200	1.0151	1.0116	1.0089	1.0065	1.0042	1.0028	1.0012	1.0000
40'	1.1157	1.0766	1.0569	1.0450	1.0369	1.0266	1.0201	1.0154	1.0118	1.0087	1.0056	1.0038	1.0016	0.9999
50'	1.1446	1.0958	1.0711	1.0562	1.0461	1.0332	1.0251	1.0193	1.0147	1.0108	1.0069	1.0047	1.0020	0.9999
1° 0'	1.1735	1.1149	1.0853	1.0674	1.0553	1.0398	1.0301	1.0231	1.0177	1.0129	1.0083	1.0056	1.0023	0.9998
10'	1.2024	1.1340	1.0995	1.0787	1.0645	1.0464	1.0351	1.0269	1.0206	1.0151	1.0097	1.0065	1.0027	0.9998
20'	1.2313	1.1531	1.1137	1.0898	1.0737	1.0530	1.0400	1.0308	1.0235	1.0172	1.0110	1.0074	1.0030	0.9997
30'	1.2601	1.1722	1.1279	1.1010	1.0829	1.0596	1.0450	1.0346	1.0264	1.0193	1.0123	1.0083	1.0034	0.9997
40'	1.2890	1.1913	1.1421	1.1122	1.0921	1.0662	1.0500	1.0384	1.0292	1.0214	1.0137	1.0091	1.0037	0.9996
50'	1.3178	1.2104	1.1562	1.1234	1.1012	1.0728	1.0549	1.0421	1.0321	1.0235	1.0150	1.0100	1.0040	0.9995
2° 0'	1.3466	1.2294	1.1704	1.1346	1.1104	1.0794	1.0598	1.0459	1.0350	1.0256	1.0163	1.0109	1.0044	0.9994
10'	1.3755	1.2485	1.1845	1.1457	1.1195	1.0859	1.0648	1.0497	1.0379	1.0276	1.0176	1.0117	1.0047	0.9993
20'	1.4043	1.2675	1.1986	1.1569	1.1286	1.0925	1.0697	1.0535	1.0407	1.0297	1.0189	1.0126	1.0050	0.9992
30'	1.4331	1.2866	1.2127	1.1680	1.1377	1.0990	1.0746	1.0572	1.0435	1.0318	1.0202	1.0134	1.0053	0.9990
40'	1.4618	1.3056	1.2268	1.1791	1.1469	1.1055	1.0795	1.0610	1.0464	1.0338	1.0215	1.0142	1.0055	0.9989
50'	1.4906	1.3246	1.2409	1.1902	1.1560	1.1120	1.0844	1.0647	1.0490	1.0359	1.0227	1.0150	1.0058	0.9988
3° 0'	1.5194	1.3436	1.2550	1.2013	1.1650	1.1185	1.0893	1.0684	1.0520	1.0379	1.0240	1.0158	1.0061	0.9986
10'	1.5481	1.3626	1.2691	1.2124	1.1741	1.1250	1.0942	1.0721	1.0548	1.0399	1.0252	1.0166	1.0063	0.9985
20'	1.5768	1.3816	1.2832	1.2235	1.1832	1.1315	1.0990	1.0758	1.0576	1.0419	1.0265	1.0174	1.0066	0.9983
30'	1.6056	1.4005	1.2972	1.2346	1.1923	1.1380	1.1039	1.0795	1.0604	1.0439	1.0277	1.0182	1.0068	0.9981
40'	1.6343	1.4195	1.3113	1.2456	1.2013	1.1445	1.1087	1.0832	1.0632	1.0459	1.0289	1.0190	1.0071	0.9980
50'	1.6630	1.4384	1.3253	1.2567	1.2103	1.1509	1.1136	1.0869	1.0660	1.0479	1.0301	1.0197	1.0073	0.9978
4° 0'	1.6916	1.4573	1.3393	1.2677	1.2194	1.1574	1.1184	1.0906	1.0687	1.0499	1.0313	1.0205	1.0075	0.9976
10'	1.7203	1.4763	1.3533	1.2788	1.2284	1.1638	1.1232	1.0942	1.0715	1.0519	1.0325	1.0212	1.0077	0.9974
20'	1.7489	1.4952	1.3673	1.2898	1.2374	1.1703	1.1280	1.0979	1.0742	1.0538	1.0337	1.0220	1.0079	0.9971
30'	1.7776	1.5141	1.3813	1.3008	1.2464	1.1767	1.1328	1.1015	1.0770	1.0558	1.0349	1.0227	1.0081	0.9969
40'	1.8062	1.5329	1.3953	1.3118	1.2554	1.1831	1.1376	1.1052	1.0797	1.0577	1.0361	1.0234	1.0083	0.9967
50'	1.8348	1.5518	1.4092	1.3228	1.2644	1.1895	1.1424	1.1098	1.0824	1.0596	1.0373	1.0241	1.0085	0.9964
5° 0'	1.8634	1.5707	1.4232	1.3337	1.2733	1.1959	1.1472	1.1124	1.0851	1.0616	1.0384	1.0248	1.0086	0.9962
10'	1.8920	1.5895	1.4371	1.3447	1.2823	1.2023	1.1519	1.1160	1.0878	1.0635	1.0396	1.0255	1.0088	0.9959
20'	1.9205	1.6083	1.4510	1.3557	1.2912	1.2086	1.1567	1.1196	1.0905	1.0654	1.0407	1.0262	1.0089	0.9957

Interpolation for correction factors corresponding to values $(-\alpha + \beta - \gamma)$ lying between those given in the table, may be made without error. Interpolation for correction factors corresponding to values of $\cos \theta_2$ lying between those given in the table, may be made without exceeding an error of 0.0010 in the sections of the tables lying between the heavy black lines; outside of these sections, and in all cases where the adjacent values of $\cos \theta_2$ are separated by the heavy black lines the maximum error in interpolation will exceed 0.0010.

ACCORDING TO ASA STANDARDS:

α IS POSITIVE WHEN THE CURRENT IN THE WATTMETER POTENTIAL CIRCUIT LEADS THE VOLTAGE.

β IS POSITIVE WHEN THE SECONDARY CURRENT LEADS THE PRIMARY CURRENT.

γ IS POSITIVE WHEN THE SECONDARY VOLTAGE LEADS THE PRIMARY VOLTAGE.

† IN THE CASE OF POLYPHASE MEASUREMENTS, THE METER OR ELEMENT IN EACH PHASE MUST BE CORRECTED SEPARATELY, CONSIDERING θ AS THE ANGLE BETWEEN THE VOLTAGE AND CURRENT ON THE METER OR ELEMENT BEING CORRECTED (NOT THE ANGLE REPRESENTED BY THE POLYPHASE POWER FACTOR).

Table 17(a)—Instrument Potential Transformer—Transformer Correction Factors

Ratio Correction Factor (RCF)	Phase Angle γ	Transformer Correction Factor (TCF)					Ratio Correction Factor (RCF)	Phase Angle γ	Transformer Correction Factor (TCF)					
		Power Factor of Metered Load—Lagging							Power Factor of Metered Load—Lagging					
		0.6	0.7	0.8	0.9	1.0			0.6	0.7	0.8	0.9	1.0	
0.995	-15'	0.9892	0.9905	0.9917	0.9929	0.9950	1.000 continued	+ 5'	1.0019	1.0015	1.0011	1.0007	1.0000	
	-10'	0.9911	0.9920	0.9928	0.9936	0.9950		+10'	1.0039	1.0030	1.0022	1.0014	1.0000	
	-5'	0.9931	0.9935	0.9939	0.9943	0.9950		+15'	1.0058	1.0044	1.0033	1.0021	1.0000	
	-2'	0.9942	0.9944	0.9946	0.9947	0.9950		+20'	1.0077	1.0059	1.0043	1.0028	1.0000	
	0'	0.9950	0.9950	0.9950	0.9950	0.9950		+30'	1.0116	1.0089	1.0065	1.0042	1.0000	
	+2'	0.9958	0.9956	0.9954	0.9953	0.9950		1.001	-15'	0.9952	0.9965	0.9977	0.9989	1.0010
	+5'	0.9969	0.9965	0.9961	0.9957	0.9950			-10'	0.9971	0.9980	0.9988	0.9996	1.0010
	+10'	0.9989	0.9980	0.9972	0.9964	0.9950			-5'	0.9991	0.9995	0.9999	1.0003	1.0010
	+15'	1.0008	0.9994	0.9983	0.9971	0.9950			-2'	1.0002	1.0004	1.0006	1.0007	1.0010
	+20'	1.0027	1.0009	0.9993	0.9978	0.9950			0'	1.0010	1.0010	1.0010	1.0010	1.0010
	+30'	1.0065	1.0039	1.0015	0.9992	0.9950			+2'	1.0018	1.0016	1.0014	1.0013	1.0010
	0.996	-15'	0.9902	0.9915	0.9927	0.9939			0.9960	1.002	+5'	1.0029	1.0025	1.0021
-10'		0.9921	0.9930	0.9938	0.9946	0.9960	+10'		1.0049		1.0040	1.0032	1.0024	1.0010
-5'		0.9941	0.9945	0.9949	0.9953	0.9960	+15'		1.0068		1.0054	1.0043	1.0031	1.0010
-2'		0.9952	0.9954	0.9956	0.9957	0.9960	+20'		1.0087		1.0069	1.0053	1.0038	1.0010
0'		0.9960	0.9960	0.9960	0.9960	0.9960	+30'		1.0126		1.0099	1.0075	1.0052	1.0010
+2'		0.9968	0.9966	0.9964	0.9963	0.9960	1.003		-15'		0.9962	0.9975	0.9987	0.9999
+5'		0.9979	0.9975	0.9971	0.9967	0.9960		-10'	0.9981		0.9990	0.9998	1.0006	1.0020
+10'		0.9999	0.9990	0.9982	0.9974	0.9960		-5'	1.0001		1.0005	1.0009	1.0013	1.0020
+15'		1.0018	1.0004	0.9993	0.9981	0.9960		-2'	1.0012		1.0014	1.0016	1.0017	1.0020
+20'		1.0037	1.0019	1.0003	0.9988	0.9960		0'	1.0020		1.0020	1.0020	1.0020	1.0020
+30'		1.0076	1.0049	1.0025	1.0002	0.9960		+2'	1.0028		1.0026	1.0024	1.0023	1.0020
0.997		-15'	0.9912	0.9925	0.9937	0.9949		0.9970	1.003		+5'	1.0039	1.0035	1.0031
	-10'	0.9931	0.9940	0.9948	0.9956	0.9970		+10'		1.0059	1.0050	1.0042	1.0034	1.0020
	-5'	0.9951	0.9955	0.9959	0.9963	0.9970		+15'		1.0078	1.0064	1.0053	1.0041	1.0020
	-2'	0.9962	0.9964	0.9966	0.9967	0.9970		+20'		1.0097	1.0079	1.0063	1.0048	1.0020
	0'	0.9970	0.9970	0.9970	0.9970	0.9970		+30'		1.0136	1.0109	1.0085	1.0062	1.0020
	+2'	0.9978	0.9976	0.9974	0.9973	0.9970		1.004		-15'	0.9972	0.9985	0.9997	1.0099
	+5'	0.9989	0.9985	0.9981	0.9977	0.9970	-10'			0.9991	1.0000	1.0008	1.0016	1.0030
	+10'	1.0009	1.0000	0.9992	0.9984	0.9970	-5'			1.0011	1.0015	1.0019	1.0023	1.0030
	+15'	1.0028	1.0014	1.0003	0.9991	0.9970	-2'			1.0022	1.0024	1.0026	1.0027	1.0030
	+20'	1.0047	1.0029	1.0013	0.9998	0.9970	0'			1.0030	1.0030	1.0030	1.0030	1.0030
	+30'	1.0086	1.0059	1.0035	1.0012	0.9970	+2'			1.0038	1.0036	1.0034	1.0033	1.0030
	0.998	-15'	0.9922	0.9935	0.9947	0.9959	0.9980			1.004	+5'	1.0049	1.0045	1.0041
-10'		0.9941	0.9950	0.9958	0.9966	0.9980	+10'		1.0069		1.0060	1.0052	1.0044	1.0030
-5'		0.9961	0.9965	0.9969	0.9973	0.9980	+15'		1.0088		1.0074	1.0063	1.0051	1.0030
-2'		0.9972	0.9974	0.9976	0.9977	0.9980	+20'		1.0107		1.0089	1.0083	1.0058	1.0030
0'		0.9980	0.9980	0.9980	0.9980	0.9980	+30'		1.0146		1.0119	1.0095	1.0072	1.0030
+2'		0.9988	0.9986	0.9984	0.9983	0.9980	1.005		-15'		0.9982	0.9995	1.0007	1.0019
+5'		0.9999	0.9995	0.9991	0.9987	0.9980		-10'	1.0001		1.0010	1.0018	1.0026	1.0040
+10'		1.0019	1.0010	1.0002	0.9994	0.9980		-5'	1.0021		1.0025	1.0029	1.0033	1.0040
+15'		1.0038	1.0024	1.0013	1.0001	0.9980		-2'	1.0032		1.0034	1.0036	1.0037	1.0040
+20'		1.0057	1.0039	1.0023	1.0008	0.9980		0'	1.0040		1.0040	1.0040	1.0040	1.0040
+30'		1.0096	1.0069	1.0045	1.0022	0.9980		+2'	1.0048		1.0046	1.0044	1.0043	1.0040
0.999		-15'	0.9932	0.9945	0.9957	0.9969		0.9990	1.005		+5'	1.0059	1.0055	1.0051
	-10'	0.9951	0.9960	0.9968	0.9976	0.9990		+10'		1.0079	1.0070	1.0062	1.0054	1.0040
	-5'	0.9971	0.9975	0.9979	0.9983	0.9990		+15'		1.0098	1.0084	1.0073	1.0061	1.0040
	-2'	0.9982	0.9984	0.9986	0.9987	0.9990		+20'		1.0117	1.0099	1.0083	1.0068	1.0040
	0'	0.9990	0.9990	0.9990	0.9990	0.9990		+30'		1.0156	1.0129	1.0105	1.0082	1.0040
	+2'	0.9998	0.9996	0.9994	0.9993	0.9990		1.000		-15'	0.9992	1.0005	1.0017	1.0029
	+5'	1.0009	1.0005	1.0001	0.9997	0.9990	-10'			1.0011	1.0020	1.0028	1.0036	1.0050
	+10'	1.0029	1.0020	1.0012	1.0004	0.9990	-5'			1.0031	1.0035	1.0039	1.0043	1.0050
	+15'	1.0048	1.0034	1.0023	1.0011	0.9990	-2'			1.0042	1.0044	1.0046	1.0047	1.0050
	+20'	1.0067	1.0049	1.0033	1.0018	0.9990	0'			1.0050	1.0050	1.0050	1.0050	1.0050
	+30'	1.0106	1.0079	1.0055	1.0032	0.9990	+2'			1.0058	1.0056	1.0054	1.0053	1.0050
	1.000	-15'	0.9942	0.9955	0.9967	0.9979	1.0000			1.000	+5'	1.0069	1.0065	1.0061
-10'		0.9961	0.9970	0.9978	0.9986	1.0000	+10'		1.0089		1.0080	1.0072	1.0064	1.0050
-5'		0.9981	0.9985	0.9989	0.9993	1.0000	+15'		1.0108		1.0094	1.0083	1.0071	1.0050
-2'		0.9992	0.9994	0.9996	0.9997	1.0000	+20'		1.0127		1.0109	1.0093	1.0078	1.0050
0'		1.0000	1.0000	1.0000	1.0000	1.0000	+30'		1.0167		1.0139	1.0115	1.0092	1.0050
+2'		1.0008	1.0006	1.0004	1.0003	1.0000								

Note: Interpolation between points may be made for intermediate values of ratio correction factor, phase angle or line power factor.

Table 17(b)—Instrument Current Transformer—Transformer Correction Factors

Ratio correction Factor (RCF)	Phase Angle β	Transformer Correction Factor (TCF)					Ratio Correction Factor (RCF)	Phase Angle β	Transformer Correction Factor (TCF)							
		Power Factor of Metered Load—Lagging							Power Factor of Metered Load—Lagging							
		0.6	0.7	0.8	0.9	1.0			0.6	0.7	0.8	0.9	1.0			
0.995	-15'	1.0008	0.9994	0.9983	0.9971	0.9950	1.000 continued	+5'	0.9981	0.9985	0.9989	0.9993	1.0000			
	-10'	0.9989	0.9980	0.9972	0.9964	0.9950		+10'	0.9961	0.9970	0.9978	0.9986	1.0000			
	-5'	0.9969	0.9965	0.9961	0.9957	0.9950		+15'	0.9942	0.9955	0.9967	0.9979	1.0000			
	-2'	0.9958	0.9956	0.9954	0.9953	0.9950		+20'	0.9922	0.9940	0.9956	0.9972	1.0000			
	0'	0.9950	0.9950	0.9950	0.9950	0.9950		+30'	0.9883	0.9911	0.9934	0.9957	1.0000			
	+2'	0.9942	0.9944	0.9946	0.9947	0.9950		1.001	-15'	1.0068	1.0054	1.0043	1.0031	1.0010		
	+5'	0.9931	0.9935	0.9939	0.9943	0.9950			-10'	1.0049	1.0040	1.0032	1.0024	1.0010		
	+10'	0.9911	0.9920	0.9928	0.9936	0.9950			-5'	1.0029	1.0025	1.0021	1.0017	1.0010		
	+15'	0.9892	0.9905	0.9917	0.9929	0.9950			-2'	1.0018	1.0016	1.0014	1.0013	1.0010		
	+20'	0.9872	0.9890	0.9906	0.9922	0.9950			0'	1.0010	1.0010	1.0010	1.0010	1.0010		
	+30'	0.9834	0.9861	0.9884	0.9907	0.9950			+2'	1.0002	1.0004	1.0006	1.0007	1.0010		
	0.996	-15'	1.0018	1.0004	0.9993	0.9981			0.9960	1.002	+5'	0.9991	0.9995	0.9999	1.0003	1.0010
		-10'	0.9999	0.9990	0.9982	0.9974			0.9960		+10'	0.9971	0.9980	0.9988	0.9996	1.0010
-5'		0.9979	0.9975	0.9971	0.9967	0.9960	+15'		0.9952		0.9965	0.9977	0.9989	1.0010		
-2'		0.9968	0.9966	0.9964	0.9963	0.9960	+20'		0.9932		0.9950	0.9966	0.9982	1.0010		
0'		0.9960	0.9960	0.9960	0.9960	0.9960	+30'		0.9893		0.9921	0.9944	0.9967	1.0010		
+2'		0.9952	0.9954	0.9956	0.9957	0.9960	1.003		-15'		1.0078	1.0064	1.0053	1.0041	1.0020	
+5'		0.9941	0.9945	0.9949	0.9953	0.9960			-10'		1.0059	1.0050	1.0042	1.0034	1.0020	
+10'		0.9921	0.9930	0.9938	0.9946	0.9960		-5'	1.0039		1.0035	1.0031	1.0027	1.0020		
+15'		0.9902	0.9915	0.9927	0.9939	0.9960		-2'	1.0028		1.0026	1.0024	1.0023	1.0020		
+20'		0.9882	0.9900	0.9916	0.9932	0.9960		0'	1.0020		1.0020	1.0020	1.0020	1.0020		
+30'		0.9843	0.9871	0.9894	0.9917	0.9960		+2'	1.0012		1.0014	1.0016	1.0017	1.0020		
0.997		-15'	1.0028	1.0014	1.0003	0.9991		0.9970	1.004		+5'	1.0001	1.0005	1.0009	1.0013	1.0020
		-10'	1.0009	1.0000	0.9992	0.9984		0.9970			+10'	0.9981	0.9990	0.9998	1.0006	1.0020
	-5'	0.9989	0.9985	0.9981	0.9977	0.9970		+15'		0.9962	0.9975	0.9987	0.9999	1.0020		
	-2'	0.9978	0.9976	0.9974	0.9973	0.9970		+20'		0.9942	0.9960	0.9976	0.9992	1.0020		
	0'	0.9970	0.9970	0.9970	0.9970	0.9970		+30'		0.9903	0.9931	0.9954	0.9977	1.0020		
	+2'	0.9962	0.9964	0.9966	0.9967	0.9970		1.005		-15'	1.0088	1.0074	1.0063	1.0051	1.0030	
	+5'	0.9951	0.9955	0.9959	0.9963	0.9970				-10'	1.0069	1.0060	1.0052	1.0044	1.0030	
	+10'	0.9931	0.9940	0.9948	0.9956	0.9970	-5'			1.0049	1.0045	1.0041	1.0037	1.0030		
	+15'	0.9912	0.9925	0.9937	0.9949	0.9970	-2'			1.0038	1.0036	1.0034	1.0033	1.0030		
	+20'	0.9892	0.9910	0.9926	0.9942	0.9970	0'			1.0030	1.0030	1.0030	1.0030	1.0030		
	+30'	0.9853	0.9881	0.9904	0.9927	0.9970	+2'			1.0022	1.0024	1.0026	1.0027	1.0030		
	0.998	-15'	1.0038	1.0024	1.0013	1.0001	0.9980			1.005	+5'	1.0011	1.0015	1.0019	1.0023	1.0030
		-10'	1.0019	1.0010	1.0002	0.9994	0.9980				+10'	0.9991	1.0000	1.0008	1.0016	1.0030
-5'		0.9999	0.9995	0.9991	0.9987	0.9980	+15'		0.9972		0.9985	0.9997	1.0009	1.0030		
-2'		0.9988	0.9986	0.9984	0.9983	0.9980	+20'		0.9952		0.9970	0.9986	1.0002	1.0030		
0'		0.9980	0.9980	0.9980	0.9980	0.9980	+30'		0.9913		0.9941	0.9964	0.9987	1.0030		
+2'		0.9972	0.9974	0.9976	0.9977	0.9980	1.006		-15'		1.0098	1.0084	1.0073	1.0061	1.0040	
+5'		0.9961	0.9965	0.9969	0.9973	0.9980			-10'		1.0079	1.0070	1.0062	1.0054	1.0040	
+10'		0.9941	0.9950	0.9958	0.9966	0.9980		-5'	1.0059		1.0055	1.0051	1.0047	1.0040		
+15'		0.9922	0.9935	0.9947	0.9959	0.9980		-2'	1.0048		1.0046	1.0044	1.0043	1.0040		
+20'		0.9902	0.9920	0.9936	0.9952	0.9980		0'	1.0040		1.0040	1.0040	1.0040	1.0040		
+30'		0.9863	0.9891	0.9914	0.9937	0.9980		+2'	1.0032		1.0034	1.0036	1.0037	1.0040		
0.999		-15'	1.0048	1.0034	1.0023	1.0011		0.9990	1.007		+5'	1.0021	1.0025	1.0029	1.0033	1.0040
		-10'	1.0029	1.0020	1.0012	1.0004		0.9990			+10'	1.0001	1.0010	1.0018	1.0026	1.0040
	-5'	1.0009	1.0005	1.0001	0.9997	0.9990		+15'		0.9982	0.9995	1.0007	1.0019	1.0040		
	-2'	0.9998	0.9996	0.9994	0.9993	0.9990		+20'		0.9962	0.9980	0.9996	1.0012	1.0040		
	0'	0.9990	0.9990	0.9990	0.9990	0.9990		+30'		0.9923	0.9951	0.9974	0.9997	1.0040		
	+2'	0.9982	0.9984	0.9986	0.9987	0.9990		1.008		-15'	1.0108	1.0094	1.0083	1.0071	1.0050	
	+5'	0.9971	0.9975	0.9979	0.9983	0.9990				-10'	1.0089	1.0080	1.0072	1.0064	1.0050	
	+10'	0.9951	0.9960	0.9968	0.9976	0.9990	-5'			1.0069	1.0065	1.0061	1.0057	1.0050		
	+15'	0.9932	0.9945	0.9957	0.9969	0.9990	-2'			1.0058	1.0056	1.0054	1.0053	1.0050		
	+20'	0.9912	0.9930	0.9946	0.9962	0.9990	0'			1.0050	1.0050	1.0050	1.0050	1.0050		
	+30'	0.9873	0.9901	0.9924	0.9947	0.9990	+2'			1.0042	1.0044	1.0046	1.0047	1.0050		
	1.000	-15'	1.0058	1.0044	1.0033	1.0021	1.0000			1.009	+5'	1.0031	1.0035	1.0039	1.0043	1.0050
		-10'	1.0039	1.0030	1.0022	1.0014	1.0000				+10'	1.0011	1.0020	1.0028	1.0036	1.0050
-5'		1.0019	1.0015	1.0011	1.0007	1.0000	+15'		0.9992		1.0005	1.0017	1.0029	1.0050		
-2'		1.0008	1.0006	1.0004	1.0003	1.0000	+20'		0.9972		0.9990	1.0006	1.0022	1.0050		
0'		1.0000	1.0000	1.0000	1.0000	1.0000	+30'		0.9932		0.9961	0.9984	1.0007	1.0050		
+2'		0.9992	0.9994	0.9996	0.9997	1.0000										

Note: Interpolation between points may be made for intermediate values of ratio correction factor, phase angle or line power factor.

Determining CT Burden—When two or more instruments are connected in series, the exact value of the resultant burden in the CT can be calculated from the resistance and reactance of each instrument. The total resistance is the sum of the resistances of the individual instruments. The total reactance is the sum of the reactances of the individual instruments. Usually the burdens imposed by the leads to the instruments are sufficiently large to be appreciable and should be added to the burdens imposed by the instruments. The burdens may be given in volt-amperes rather than in ohms; then the components are given in watts and reactive volt-amperes (vars). Then the total watts and total vars are the sum of the individual values. This is expressed in Equation 54.

$$\text{Total burden (ohms)} = \sqrt{(\sum R)^2 + (\sum X_L)^2} \quad (a)$$

$$\text{Total burden (volt-amperes)} = \sqrt{(\sum \text{watts})^2 + (\sum \text{vars})^2} \quad (b)$$

$$\text{Burden power factor} = \frac{\text{total resistance}}{\text{total ohms}} \quad (c)$$

$$\text{Burden power factor} = \frac{\text{total watts}}{\text{total volt-amperes}} \quad (d)$$

Typical burdens imposed on current transformers by various instruments are given in Table 19.

Polarity of an Instrument Transformer—When instrument transformers are used with instruments and relays which operate only according to magnitude of voltage or current, the phase relationship is of no consequence. Reversal of connections to the meter gives the same indication on the relay or instrument.

The relative phase positions of two or more quantities applied to devices which depend on the interaction of the quantities for correct operation are of prime importance. Product meters and relays such as wattmeters, watthour meters, power relays, and directional relays are devices in which the phase relationship of the quantities involved, or the phase relationship of each with respect to a common reference, must be known. For correct operation of such devices, it is necessary to know the relative directions of currents in the primary and secondary windings. The polarity markings on the instrument transformer are the identifications used to indicate the relative instantaneous polarities of the primary and secondary currents and voltages.

On potential transformers, during most of each half-cycle in which the identified primary terminal is positive with respect to the unidentified primary terminal; the identified secondary terminal is also positive with respect to the unidentified secondary terminal. The polarity marks are so placed on current transformers that during most of each half-cycle, when the direction of the instantaneous current is into the identified primary terminal, the direction of the instantaneous secondary current is out of the corresponding identified secondary terminal. This convention is in accord with that by which standard terminal markings H_1 , X_1 , are correlated.³⁷ This is illustrated in Fig. 54. Various methods of determining the polarity of instrument transformers are described in the Standards.

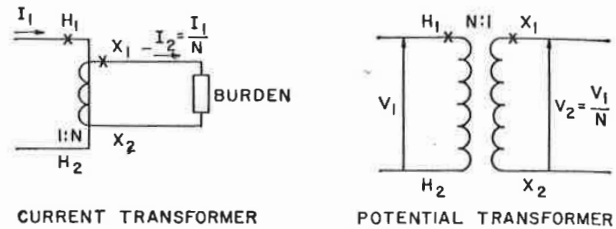

Fig. 54—Circuit diagrams showing significance of polarity identification and notation of current and potential transformers

30. Operating Limitations of Instrument Transformers

The effects of some variations in normal operating conditions on instrument transformers have been discussed in the section regarding the particular type of transformer. The operation of transformers under some rather abnormal conditions are of prime importance and are discussed here.

Neutral Inversion^{46,47}—Potential transformers connected wye-wye with the high voltage neutral grounded on an otherwise ungrounded system are universally subject to oscillations of the neutral from the third harmonic voltage developed, and are universally subject to inversion of the neutral, under favorable conditions of line capacitance and inductance. Such reference is usually given to the condition when the neutral is displaced to points outside of the delta.

Special designs can be made which will practically preclude inversion except under most unusual conditions, but the best prevention of inversion is a ballasting load on each secondary winding. A resistance load in watts equal to the exciting volt-amperes of the transformer of normal line-to-ground voltage will practically prevent inversion.

Overvoltages—The exciting current and ratio error and phase angle of a potential transformer increase rapidly as the applied voltage exceeds 110 per cent of normal. In general, if the applied voltage exceeds 110 per cent, the errors become excessive. Instrument transformers, according to ASA Standards, shall be capable of operating continuously at 10 per cent above rated voltage.

Momentary overvoltages up to twice normal voltage can usually be absorbed by potential transformers. This usually is important only in the event of a ground-fault which results in application of line-to-line voltage to a wye-connected transformer. Unless specifically designed for this contingency, potential transformers will not withstand continuous operation at $\sqrt{3}$ times normal voltage. This has been discussed previously. Under no conditions should the thermal voltampere-output rating of the transformer be exceeded.

Operation of Current Transformer With Secondary Open-Circuited—If the secondary circuit of a current transformer is opened while current flows in the primary circuit, the demagnetizing effect of the secondary winding mmf, which is usually large, is removed. Normally, the

Table 18—Burdens Imposed by Instruments and Meters on Potential Transformers

Values given are for a single element.

Kind and Type of Instrument	25 Cycles				60 Cycles				Remarks
	Volt-Amperes	Watts	Vars	% Power Factor	Volt-Amperes	Watts	Vars	% Power Factor	
Voltmeters									
0-150 volts CA, MA, NA, VA.....	0.9	0.9	0.0	100.	0.9	0.9	0.0	0.0	
0-150 volts HA, KA, JY-2, LY-2, SY-2, DY-2.	3.51	3.51	0.023	99. +	3.51	3.51	0.055	99. +	ext. res. on KA, JY-2, DY-2
0-150 volts DY, LY, SY, JY, WY.....	9.5	9.5	0.0	100.	9.5	9.5	0.1	100.	ext. res. used
0-150 volts SM, TM, GM.....	11.5	10.9	3.82	94.7	10.3	9.9	1.02	96.	ext. res. used
0-150 volts PY-4.....	.9	.9	0.0	100.	.9	.9	0.0	100.	
0-150 volts PY-5.....	2.84	2.84	0.0	100.	2.84	2.84	0.0	100.	
0-300 volts PY-4.....	.25	.25	0.0	100.	.25	.25	0.0	100.	
0-300 volts PY-5.....	.75	.75	0.0	100.	.75	.75	0.0	100.	
0-150 volts PC.....	5.45	5.45	0.0	100.	5.45	5.45	0.0	100.	
90-130 volts } type U recorder.....	33.8	33.6	4.7	99.	32.5	31.4	8.5	97.	ext. res. used
90-140 volts } type A recorder.....	23.4	22.7	3.9	99.	23.4	21.5	9.4	92.	ext. res. used
90-140 volts type R recorder.....	13.8	13.8	0.05	100.	13.8	13.8	0.1	100.	ext. res. used
0-150 volts type R recorder.....	11.4	11.4	0.4	100.	11.4	11.4	0.08	100.	ext. res. used
Wattmeters									
single phase HY, KY.....	3.27	3.27	0.0	100.	3.27	3.27	0.0	100.	ext. res. on KY
polyphase HY, KY.....	2.88	2.88	0.0	100.	2.88	2.88	0.0	100.	ext. res. used on KY
single phase DY, LY, SY, WY.....	11.6	11.6	0.0	100.	11.6	11.6	0.0	100.	ext. res. used
polyphase DY, LY, SY, WY.....	8.3	8.3	0.0	100.	8.3	8.3	0.0	100.	ext. res. used
0-75 volts } PY-4.....	1.58	1.58	0.0	100.	1.58	1.58	0.0	100.	
0-150 volts } PY-4.....	1.21	1.21	0.0	100.	1.21	1.21	0.0	100.	
0-75 volts } PY-5.....	5.6	5.6	0.0	100.	5.6	5.6	0.0	100.	
0-150 volts } PY-5.....	2.12	2.12	0.0	100.	2.12	2.12	0.0	100.	
0-300 volts } PY-5.....	5.45	5.45	0.0	100.	5.45	5.45	0.0	100.	
types SM, TM, GM.....	8.65	7.32	4.58	85.	10.1	9.16	4.26	91.	ext. res. used
types M, R recorders.....	10.7	10.7	0.0	100.	10.7	10.7	0.0	100.	ext. res. used
Wathour Meters									
single phase, OC, CA, CS, DA, DS.....	8.7	1.4	8.6	16.	
polyphase C-2, C-3; R-2, R-3; RI-2, RI-3....	12.7	2.3	12.4	18.	
polyphase CS-2, CA-2, CB-2.....	8.5	1.7	8.3	20.	
polyphase DSP-2, DAP-2, etc.....	6.1	1.4	5.94	23.	
demand attachment—additional on any meter	2.3	1.5	1.7	65.	
polyphase demand meters C-2, C-3, etc.....	14.6	3.8	14.1	26.	
reactive VA type RI.....	11.0	1.6	10.8	15.	
Power Factor Meters									
single phase DY, LY, SY, HY, KY.....	17.8	13.9	11.1	78.	17.8	13.9	11.1	78.	ext. reactor used
polyphase 50-100-50, DY, LY, SY, WY.....	12.2	12.2	0.0	100.	12.2	12.2	0.0	100.	ext. res. used
polyphase 50-100-50, HY, KY.....	3.7	3.7	0.0	100.	3.7	3.7	0.0	100.	
polyphase 10-100-80, DY, LY, SY, WY.....	10.	9.8	3.7	93.7	10.5	9.8	3.7	93.7	ext. res. used
polyphase 10-100-80, HY, KY.....	3.2	3.2	0.0	100.	3.2	3.2	0.0	100.	
types SI, TI.....	12.0	10.9	4.95	91.	12.0	10.9	4.95	91.	ext. res. used
reactive factor SI, TI.....	12.0	10.9	4.95	91.	12.0	10.9	4.95	91.	ext. res. used
PC portable.....	8.7	6.5	5.8	75.	8.7	6.5	5.8	75.	
polyphase recorder, type R.....	10.7	10.7	0.0	100.	10.7	10.7	0.0	100.	
Frequency Meters									
resonant type HY, KY, LY, DY, SY, WY..	3.5	3.5	.13	100.	3.5	3.5	0.24	100.	ext. reactor used
resistor-reactor type SY, LY, DY, WY....	16.3	13.9	8.5	85.	16.3	13.9	8.5	85.	ext. reactor used
types SD, TD, PD.....	21.8	16.3	14.4	75.	21.8	16.3	14.4	75.	ext. reactor used
types M, R, reactor.....	27.1	23.2	14.1	85.	28.4	24.0	15.2	85.	ext. reactor used
type RF recorder.....	30.0	12.0	27.5	40.	30.0	12.0	27.5	40.	
Synchrosopes									
SI, TI bottom circuit running machine.....	10.9	10.0	4.25	92.0	10.9	10.0	4.25	92.0	ext. reactor used
SI, TI top circuit incoming machine.....	12.2	12.2	.25	100.	12.2	12.2	100.	
HA bottom circuit incoming machine.....	3.2	2.1	2.4	65.	3.2	2.1	2.4	65.	
HA top circuit running machine.....	2.9	1.8	2.2	63.	2.9	1.8	2.2	63.	ext. reactor used

Table 19—Burdens Imposed by Instruments and Meters on Current Transformers

Values given are for a single element. For watt-hour meters, values shown are for 5-ampere meters at 5 amperes except (†) which are 2½ ampere meters at 5 amperes. Data are per winding per stator.

Kind and type of instrument	25 Cycles					60 Cycles				
	Impedance: Ohms	Resistance: Ohms	Reactance: Ohms	Voltage: Amperes	% Power Factor	Impedance: Ohms	Resistance: Ohms	Reactance: Ohms	Voltage: Amperes	% Power Factor
Ammeters										
5 amp. CA, MA, NA, PY-4 portable.....	.0108	.0108	.00092	0.27	99.8	.0112	.0108	.00212	0.28	99.1
5 amp. HA, KA, SY-2, LY-2, DY-2, JY-2, PY-5 portable...	.0180	.0172	.00568	0.45	95.0	.0216	.0172	.01344	0.54	79.0
5 amp. SY, LY, DY, JY, WY...	.1280	.1280	.01840	3.20	99.0	.1320	.1240	.04400	3.30	94.8
5 amp. SM, TM, JM.....	.2520	.2400	.07600	6.30	95.0	.1128	.1112	.03520	2.82	98.5
5 amp. PM portable.....	.1800	.1600	.08000	4.50	89.0	.1800	.1600	.08000	4.50	89.0
5 amp. A recorder.....	.3760	.1880	.32400	9.40	49.7	.3800	.0880	.37200	9.50	23.2
5 amp. R recorder.....	.1512	.1464	.03760	3.78	96.3	.1548	.1320	.08120	3.87	85.3
5 amp. U recorder.....	.2860	.2180	.18800	7.15	76.2	.5760	.2840	.50400	14.40	49.3
Wattmeters										
5 amp. HY, KY, DY, LY, SY, WY	.0760	.0760	.00490	1.90	99.5	.0760	.0760	.01160	1.90	99.0
4 amp. HY, KY, DY, LY, SY, WY	.1200	.1200	.00800	3.00	99.0	.1200	.1200	.00176	3.00	99.0
7½ amp. HY, KY, SY, LY, DY, WY.....	.0308	.0308	.00200	0.77	99.0	.0312	.0308	.00480	0.78	99.0
5 amp. SM, TM, GM.....	.0420	.0400	.01200	1.05	95.8	.0480	.0400	.02760	1.20	82.5
5 amp. PY-4 portable.....	.0112	.0108	.00100	0.28	99.0	.0124	.0108	.00560	0.31	97.5
5 amp. PY-5 portable.....	.0324	.0320	.00240	0.81	99.0	.0328	.0320	.00600	0.82	98.0
5 amp. PC portable.....	.1004	.0920	.04000	2.51	92.0	.1292	.0920	.09600	3.23	69.0
5 amp. R recorder.....	.1728	.1648	.05040	4.32	95.5	.2148	.1648	.12480	5.37	77.6
Watt-hour Meters										
single phase OC, CA, CS.....0128	.0072	.0106	0.32	56
single phase, DA, DS†.....0460	.020	.0415	1.15	43
polyphase { C-2, C-3, etc. } { R-2, R-3, etc. } { RI-2, RI-3, etc. }0236	.0104	.0212	0.59	44
same with demand attachment or demand meter reactive VA type RI.....05	.0352	.0355	1.25	70
polyphase { CS-2, CS-3, etc. } { CA-2, CA-3, etc. } { CB-2, CB-3, etc. } { RK-2, RK-3, etc. }0116	.0064	.0097	0.29	55
polyphase DSP-2, DAP-2, etc.....0236	.0104	.0212	0.59	44
050	.019	.0468	1.25	38
Power Factor Meters										
5 amp. HY, KY, DY, LY, SY, WY—100° scale.....	.0160	.0160	.04800	1.90	99.5	.0160	.0760	.11660	1.90	99.0
5 amp. HA—360° scale.....	.1076	.1056	.01880	2.69	98.0	.1152	.1056	.04520	2.88	92.0
5 amp. SI, TI—360° scale.....	.0656	.0600	.02600	1.64	92.0	.0868	.0600	.06240	2.17	69.0
5 amp. PC-portable.....	.1004	.0920	.04000	2.51	92.0	.1332	.0920	.09600	3.33	69.0
5 amp. R recorder.....	.1728	.1648	.05040	4.32	95.5	.2148	.1648	.12480	5.37	77.6
type TA industrial analyzer.....	.5040	.5000	.05600	12.60	99.0	.5280	.5240	.06800	13.20	99.0

exciting current, when the transformer is carrying rated current and maximum rated burden, is of the order of 0.5 per cent primary current. If the secondary circuit is opened when the primary is carrying rated current, the primary current becomes the exciting current and is a value of about 200 times normal. This results in a very high core flux density and correspondingly high induced voltage in the transformer winding. The abnormally high flux density will cause excessive core loss, which if sustained for a sufficiently long period of time, may result in destructive heating in the core. It may also leave a high residual flux in the core, which can

subsequently result in a change in the ratio error and phase angle of the transformer. The voltage induced in the secondary winding under open-circuit conditions may be sufficiently high to constitute a hazard to the operator and the transformer insulation.

If the secondary circuit is accidentally opened, possible high residual flux can be removed by either of two methods: 1) short circuit the secondary through a 30 ohm resistor and gradually increase the primary alternating current to full rated value after which it is gradually reduced to zero; 2) with the primary open, gradually increase the alternating current through the sec-

ondary to rated value after which it is gradually reduced to zero.

Although current transformers are not intended to be operated with the secondary open-circuited, they are capable of operating in this manner for short times under emergency conditions, provided the open circuit (secondary induced voltage) does not exceed 3500-volts crest. Since the induced voltage is a function of the primary current and wave shape, overvoltage protection should be considered on its own merits in the particular application. Also, since the flux is proportional to the integral with respect to time of the induced voltage, the wave form of the induced voltage has a pronounced effect on the degree of saturation in the core. The voltage of 3500-volts crest across a closed secondary circuit may be exceeded if the rate of change of the primary current is sufficiently rapid, such as would be the case in the initial charge or discharge current of a large capacitor installation flowing through the primary winding.

Inverted Operation of Current Transformers—Although application of a current transformer as a "step-up" transformer to obtain larger currents either for metering or testing may appear reasonable, such an application can lead to serious error. Such an application may be that of using instruments of unusually high range in the measurement of very small currents. In such a case, the high-range instrument is connected in series (across) with the high-current winding and the current being measured is passed through the low-current winding: Since the impedances are reflected from the high-current (low-voltage) side to the low-current (high-voltage) side approximately as the square of the turns ratio, a very small impedance on the high-current side may represent a high impedance on the base of the low-current winding, if the turns ratio is appreciable. Such an impedance referred to the low-current winding may exceed the rated maximum burden of the transformer. Such a condition results in abnormally high transformer winding induced voltages, saturation of the core, large exciting current, and an intolerable ratio error. The high-current side impedance must be extremely low to avoid this condition.

Somewhat similar results may occur when attempting to invert a current transformer to obtain large alternating currents for test or other purpose. A load impedance referred to the high-current winding must be kept extremely low if currents of the order of the high-current rating are to be obtained. Any metering applied on the high-current winding contributes to the impedance. If saturation results, serious error can result from metering on the low-current side. Therefore, it is very difficult to obtain a high degree of accuracy when inverting a current transformer. The induced voltage referred to the low-current winding necessary for saturation may be of the order of 30 to 300 volts, the exact value depending upon the type of transformer involved.

31. Metering Outfits

The necessary instrument transformers for outdoor primary metering installations in standard insulation

classes from 2.5 kv through 161 kv are available as packaged units in metering outfits. The packaged units are available for single-phase, two-wire, three-phase, three-wire and three-phase, four-wire applications.

The single-phase outfits consist of one current transformer and one potential transformer connected to one or two high-voltage bushings and a neutral grounding bushing or grounding terminal.

The metering outfits for use on three-phase, three-wire circuits consist of two current transformers and two potential transformers connected to three high-voltage bushings. Outfits for use on three-phase, four-wire circuits consist of three current transformers and either two or three potential transformers connected to three high-voltage bushings and a neutral grounding bushing or grounding terminal.

REFERENCES

1. Development of Watthour Meters, Thomas D. Barnes, *Westinghouse Engineer*, Vol. 10, November 1950, pp. 226-32.
2. Progress in the Art of Metering Electric Energy, Pts. I, II, III, and IV, *Electrical Engineering*, Vol. 61, 1941, pp. 421-7, pp. 469-78 pp. 540-6, and pp. 581-9.
3. Lightning Protection of Domestic Watthour Meters, A. M. Opsahl, *Westinghouse Engineer*, Vol. II, May 1942, p. 38.
4. *Electrical Measurements* (book), Frank A. Laws, McGraw-Hill Book Company, 1938.
5. *Measurement of Alternate Current Energy* (book), Donald T. Canfield, McGraw-Hill Book Company, 1940.
6. *Handbook for Electrical Metermen*, 1923 Edition, (book), National Electric Light Association, 1923.
7. Design Considerations for the Life-Time Meter, Warren Schmidt and Ray Forrest, *Westinghouse Engineer*, Vol. 15, September 1955, pp. 166-9.
8. American Standard Code for Electricity Meters, ASA C12-1941, Edison Electric Institute, 1941.
9. Watt-Hour Meter Bearings, I. F. Kinnard and J. H. Goss, *AIEE Transactions*, Vol. 56, 1937, pp. 129-37.
10. Effects of Harmonics on Watthour Meter Accuracy, M. A. Faucett and C. A. Keener, *Electrical World*, October 27, 1945, pp. 82-4.
11. Watt-Hour Meter Performance with Power Rectifiers, C. T. Weller, H. E. Treckell, and F. G. Stebbins, *AIEE Transactions*, Vol. 59, 1940, pp. 449-56.
12. AEIC-EEI-NEMA Standards for Watthour Meters, EEI Pub. No. MSF-10, NEMA Pub. No. EI-20, February 1958.
13. *Electrical Metermen's Handbook*, Sixth Edition, (book), Edison Electric Institute, 1950.
14. *Westinghouse Watthour and Demand Meter Handbook*, Fifth Edition, Westinghouse Electric Corp., Meter Division.
15. Polyphase-Meter Applications, Paul MacGahan, *The Electric Journal*, Vol. 33, October 1936, pp. 453-8.
16. *Applied Mathematics for Engineers and Physicists*, Second Edition, (book), Louis Albert Pipes, McGraw-Hill Book Company, 1958.
17. Measurements of the Energy of Polyphase Currents, A. Blondell, Proc. Internat. Elec. Cong., Chicago, 1893, p. 12.
18. The Fundamental Accuracy of Single-Phase, Three-Wire Metering, E. C. Wentz and A. J. Petzinger, *AIEE Transactions*, Vol. 71, Pt. I, September 1952, pp. 295-302.
19. Reactive Metering, V. B. Shah, *Electrical Review*, Vol. 140, June 13, 1947; pp. 979-83.
20. Autotransformer Connections for Varhour Metering, E. J. Boland, *General Electric Review*, Vol. 43, July 1940, pp. 298-301.
21. Metering Reactive Loads, A. L. Carvill, *Electric Light and Power*, Vol. 36, August 1, 1958, pp. 55-60, 71-2.
22. American Standard Definitions of Electrical Terms, Group 30, ASA C42.30, 1957.

23. The Character of Thermal Storage Demand Meters, P. M. Lincoln, *AIEE Transactions*, February 1918, pp. 189-210.
24. An Improved Electrothermic Instrument, P. M. Lincoln, *AIEE Transactions*, Vol. 54, 1935, pp. 474-81.
25. New Thermal Volt-Ampere Demand Meter, M. E. Douglass and W. H. Morong, *AIEE Transactions*, Vol. 68, Pt. I, 1949, pp. 79-83.
26. A Polyphase Thermal Ampere-Demand Meter, A. J. Petzinger, *AIEE Transactions*, Vol. 66, 1947, pp. 167-74.
27. A Polyphase Thermal Kilovolt-Ampere Demand Meter, A. J. Petzinger, *AIEE Transactions*, Vol. 70, Pt. II, 1951, pp. 1774-7.
28. Recent Developments in Kilovolt-Ampere Metering, B. H. Smith and A. R. Ritter, *AIEE Transactions*, Vol. 43, 1924, pp. 297-301.
29. Improvement in Modern Meter-Testing Technique, Edward E. Lynch and Mark A. Princi, *AIEE Transactions*, Vol. 61, 1942, pp. 218-33.
30. Stroboscopic Method of Testing Watthour Meters, H. P. Sparkes, *AIEE Transactions*, Vol. 46, 1927, pp. 405-8.
31. Metering with Transformer Loss Compensators, G. B. Schleicher, *AIEE Transactions*, Vol. 66, 1947, pp. 851-61.
32. Demand Totalization Using Simplified Impulse Telemetering System, A. R. Rutter and P. MacGahan, *Electrical Journal*, Vol. 32, 1935, pp. 151-2.
33. A Report on Telemetering, Supervisory Control and Associated Communication Circuits, Joint Subcommittee of the AIEE, *Electrical Engineering*, Vol. 51, September 1932, pp. 613-20.
34. Load Totalization Pts. I, II, III, IV, E. J. Boland, *General Electric Review*, Vol. 41, 1938, pp. 194-9, 238-43, 282-7, and 326-9.
35. Load Survey Data Recorded on Tape, T. D. Barnes, *Electrical World*, Vol. 146, No. 9, August 20, 1956, pp. 125 and 128.
36. Demand Meter Produces Punched-Tape Record Fast, *Electrical World*, Vol. 146, No. 20, November 12, 1956, pp. 137-40.
37. Standard Requirements, Terminology and Test Code for Instrument Transformers, ASA C57.13, 1954, American Standards Association.
38. *Instrument Transformers* (book), B. Hague, Sir Isaac Pifman and Son, 1936.
39. Accuracy of the Formulas for the Ratio, Regulation and Angle of Transformers, P. G. Agnew and F. B. Silsbee, Scientific Papers of the Bureau of Standards, No. 211, Reprinted from Bulletin of Bureau of Standards, Vol. 10.
40. Master Test Code for Electrical Measurements in Power Circuits, AIEE Standard 552, November 1955.
41. A Study of the Current Transformer with Particular Reference to Iron Loss, P. G. Agnew, No. 164, Bulletin of the Bureau of Standards, Vol. 7, 1911.
42. Insulation Level is Criterion for Instrument Transformer Application, J. H. Chiles, Jr., *Electric Light and Power*, Vol. 25, March 1947, pp. 68-9, 72.
43. A Simple Method for Determination of Ratio Error and Phase Angle Error in Current Transformers, E. C. Wentz, *AIEE Transactions*, Vol. 60, 1941, pp. 949-54.
44. A Proposed Method of Determination of Current Transformer Errors, G. Camilli and R. L. Tenbrock, *AIEE Transactions*, Vol. 59, 1940, pp. 547-50.
45. Physical Nature of Neutral Instability, A. Boyajian and O. P. McCarty, *AIEE Transactions*, Vol. 50, 1931, pp. 317-27.
46. Experiences with Grounded-Neutral, Y-Connected Potential Transformers on Ungrounded Systems, C. T. Weller, *AIEE Transactions*, Vol. 50, 1931, pp. 299-316.
47. Ferroresonance of Grounded Potential Transformers on Ungrounded Power Systems, R. F. Karlicek and E. R. Taylor, Jr., *AIEE Transactions*, Paper No. 59-97.

CHAPTER 12

STREET LIGHTING

ROBERT A. ZIMMERMAN

The basic purpose of street lighting is to promote safety and convenience on the streets at night through adequate visibility, and to promote civic progress. Statistics show that good street-lighting installations bring about material reductions in traffic accidents, act as a deterrent to crime, and promote more business in commercial areas.

I. GENERAL

1. History¹

Oil lamps were the first artificial sources of light used for systematic illumination of streets in the United States. No records exist as to when and where the first of these installations was made. The use of gas lamps followed the oil lamps. As early as 1816, the Gas Light Company of Baltimore was founded to manufacture gas for street-lighting purposes. The first electric street-lighting systems came into existence in the late 1870's, with the open carbon-arc lamp and the carbonized-bamboo filament lamp appearing at about the same time. The open carbon-arc lamp, which required daily trimming, was followed in 1893 by the enclosed carbon-arc lamp that required only weekly trimming. The initial efficiency of the enclosed carbon-arc lamp was about four to seven lumens per watt. The flaming-arc lamps and the magnetite, or luminous-arc lamps, were a big improvement over their arc lamp predecessors. Efficiencies up to 19 lumens per watt and a lamp life of 100 hours were possible with the enclosed flaming-arc lamp, and 20 lumens per watt and a 350-hour life were possible with the magnetite lamp.

The carbonized-bamboo filament lamp of 1879 had an efficiency of 2 lumens per watt. The carbonized-cellulose filament of 1891 produced 3 lumens per watt. In 1905, the first of the metallic-filament lamps appeared. Improvements in this lamp have led to the modern, gas-filled lamps having efficiencies up to 21 lumens per watt and a service life up to 3000 hours.

Mercury lamps were first used for street lighting in 1936. The first mercury lamps had an efficiency of about 13 lumens per watt. Modern mercury lamps provide between 50 and 60 lumens per watt and have a rated service life of 6000 to 10,000 hours.

Sodium lamps, first used in 1934, have efficiencies as high as 56 lumens per watt and a service life of approximately 4000 hours.

Fluorescent lamps, which have just recently entered the street-lighting picture, produce approximately 52 lumens per watt and have a rated service life of 7500 hours.

It has been estimated that there are approximately five million street lights in service in the United States today. Of this total number, it is estimated that approximately 90 per cent of these units are filament lamps. The great majority of the remaining 10 per cent are mercury-vapor units. It has been estimated that by 1966, when the total number of street lights in the country should reach ten million, that approximately half of the lumens provided for street lighting will be from either mercury or fluorescent lamps.

2. Illumination Levels

Definitions²—The standard unit of luminous intensity in a given direction is the International Candle. An ordinary wax candle has a luminous intensity, in a horizontal direction, of approximately one candle. The International Candle is the basic quantity in all measurements of light. The luminous intensity of a light source expressed in candles is its candlepower. Candlepower is always a property of a source of light and gives information regarding luminous flux at its origin.

The unit of luminous flux is the lumen. A lumen is defined as the light flux falling on a surface one square foot in area, with every point on the surface of the area one foot away from a uniform point source of one candle. The lumen differs from the candle in that it is a measure of light flux irrespective of direction.

Illumination refers to the density of luminous flux on a surface. The unit of illumination is the foot-candle. A foot-candle is defined as the illumination at a point on a surface that is one foot from, and perpendicular to, a uniform point source of one candle. From the definition of a lumen, it is obvious that one lumen uniformly distributed over one square foot of surface produces an illumination of one foot-candle.

Brightness is the luminous intensity in a given direction per unit of projected area. A surface, or an object, has brightness by reason of light emitted, reflected, or transmitted. Brightness is ordinarily independent of distance of observation. Brightness is expressed in two ways: in candles per unit area, or in lumens per unit area. By definition, a surface emitting or reflecting light in a given direction, at the rate of one candle per square inch of projected area, has a brightness in that direction of one candle per square inch. A surface which has a brightness equal to the uniform brightness of a perfectly diffusing surface emitting or reflecting one lumen per square foot has a brightness of one footlambert. The footlambert is also the average brightness of any surface emitting or reflecting one lumen per square foot.

The following terms are commonly used in street and

highway lighting and merit definition here to avoid confusion.

The term lamp refers to the light source employed. The efficiency of a lamp, expressed in lumens per watt, is the ratio of the total luminous flux to the total power input.

A luminaire is a complete lighting device consisting of a light source together with its direct appurtenances, such as globe, reflector, refractor, housing, and such support as is integral with the housing. The pole, post, or bracket is not considered a part of the luminaire. A lighting unit is the complete assembly of pole or post with bracket and luminaire.

The absorption factor is defined as the ratio of light flux absorbed by an object or surface to the light flux incident upon it. The reflection factor, or reflectance, is defined as the ratio of light reflected by a surface to the light incident upon it.

Application Requirements—There are a number of factors that contribute to the illumination level required in street-lighting installations. An important factor, common to all street and highway safety considerations, is the volume of vehicular and pedestrian traffic. As traffic volume increases, traffic interference and exposure to accidents also increase. Good visibility is more difficult to achieve in the confusion of moving vehicles and pedestrians, for it is against this background that the accident hazard must be discerned.

In order to make logical recommendations as to illumination levels required in street-lighting applications, it is necessary to classify streets with respect to vehicular and pedestrian traffic. Table 1³ and Table 2³ give classifications of vehicular and pedestrian traffic, respectively.

Table 1—Classification of Vehicular Traffic for Roadway Lighting Purposes

Classification	Volume of Vehicular Traffic (Maximum Night Hour Both Directions)
Very light traffic	Under 150
Light traffic	150-500
Medium traffic	500-1200
Heavy traffic	1200-2400
Very heavy traffic	2400-4000
Heaviest traffic.	Over 4000

Table 2—Classification of Pedestrian Traffic

Classification	Pedestrian Volumes Crossing Vehicular Traffic Lanes
None	No pedestrians, as on express highways.
Light	As on streets in average residential districts.
Medium	As on secondary business streets.
Heavy	As on main business streets.

The reflection factor, or reflectance, of the street surface has a definite effect on the effectiveness of a street-lighting installation. Consequently, the reflectance of the street and roadway surfaces should be evaluated.

Table 3—Current Recommended Average Horizontal Footcandles*

Pedestrian Traffic (Table 2)	Vehicular Traffic Classification (Table 1)			
	Very Light (Under 150)	Light (150-500)	Medium (500-1200)	Heavy to Heaviest (1200 and up)
Heavy	0.9	1.2	1.5	1.8
Medium	0.6	0.9	1.2	1.5
Light or None	0.3	0.6	0.9	1.2

*The recommended illumination values are for roadway surfaces having reflectances of the order of three per cent. These values should be treated as minimums after proper consideration has been given to both lamp and luminaire depreciation during operation, irrespective of the method employed in maintaining the lighting system and also to provide for probable pavement reflection characteristics.

Table 3³, which gives recommended illumination levels for street lighting, takes reflectance into account.

The foot-candle values given in Table 3 are current recommended minimum practice for average illumination on the traffic-used pavement between curb lines. The lowest foot-candle value at any point should not be less than one-fourth the average value given in Table 3, except in cases of very light vehicular traffic where the lowest foot-candle value at any point may be as low as one-tenth of that value.

Pavement brightness, for the achievement of satisfactory visibility by silhouette discernment, is dependent upon the light reflection characteristics of the pavement surface. The values in Table 3 are based on rather poor pavement reflectance in the order of three per cent. For streets and traffic conditions in which silhouette discernment is important, due allowance must be made for pavement reflectances which vary from the conditions assumed above. When reflectance is favorable (in the order of ten per cent), the illumination recommended may be reduced by 33 per cent. When reflectance is unusually high (20 per cent or more), the recommended values of Table 3 may be decreased by 50 per cent. In general, these corrections will apply more specifically to streets carrying a light traffic volume where the illumination recommended is less than 0.8 footcandle. On streets carrying a heavy traffic volume, and where 1.0 foot-candle or more is recommended, visibility is more apt to depend upon discernment by surface detail; hence, corrections for pavement reflectance becomes less important.

Intersections require higher illumination than that recommended in Table 3 for the approaching streets. The illumination at an intersection should be at least equal to the sum of the illumination values provided on the streets which form the intersection.

The color of light usually does not affect the level of illumination to be provided. Studies have shown that the visibility of objects on or near the roadway is substantially the same throughout the differences in color of light from sodium, mercury, fluorescent, and filament

lamps, when the comparison is on the basis of equal amount of light and similar distribution.

3. Sources of Light

The primary purpose of a light source is the production of light, and the efficiency with which a source fulfills this purpose is expressed in terms of lumens emitted per watt of power consumed. If a source could be developed that would radiate all the input energy as monochromatic yellow-green light in the region of maximum sensitivity of the eye (5550 Angstroms), it would produce approximately 650 lumens per watt. A theoretical source of white light of maximum efficiency, emitting only visible energy without infrared or ultraviolet, would produce about 200 lumens per watt. Compared with these figures, the best available lamp efficiencies of today seem disappointingly low.

Incandescent or Filament Lamps—The filament lamp produces light by virtue of heating a wire, or filament, to incandescence by passing an electric current through it. An incandescent filament must operate in either a vacuum or an atmosphere of inert gas to prevent rapid disintegration due to oxidation.

The efficiency of filament lamps, while low compared to the theoretical values given above, has been vastly improved in the last 50 years by changing from carbon to tungsten as a filament material, by changing from vacuum to gas-filled construction, and by replacing straight filament wire with coiled, and then using coiled-coil filaments. However, the filament lamp has certain characteristics which make it inherently inefficient as a source of light, and although it is probable that efficiencies will still be raised slightly by further refinements in manufacturing processes, the maximum possible values have already been approached.

The most efficient incandescent lamps available for street-lighting purposes today have efficiencies in the order of 21 lumens per watt.

Both the life of a filament lamp and its light output are determined by its filament temperature. The higher the temperature for a given lamp, the greater the efficiency and the shorter the life. Hence, light output and life are interdependent. A lamp can be designed for long life at the expense of light output, or for high light output at the expense of life. In practice, the life for which a lamp is designed is an economic balance between the two factors, determined on the basis of the purpose for which the lamp is to be used.

Published data on lamp life refer to the average life of a group of lamps under specified test conditions, and are not intended as a guarantee of the performance of any individual lamp. As shown by the mortality curve of Fig. 1, in any large group of lamps, some will fail relatively early in life, whereas others will still continue to operate long after the end of rated life.

As a general rule, lamps should be operated at rated voltage. Overvoltage operation results in higher wattage, higher efficiency, and higher light output, but also in shorter lamp life. Undervoltage operation, while increasing lamp life, causes a reduction in wattage, in efficiency, and in light output. For example, operation of

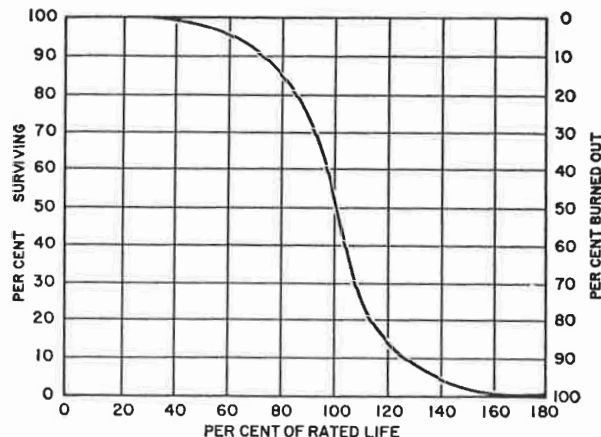

Fig. 1—Typical mortality curve for incandescent lamps.

a lamp at 95 per cent of rated voltage results in a loss of light amounting to more than 16 per cent, with a saving in wattage of only 8 per cent. Since lamp cost is almost always compared with the cost of the power to operate the lamp, the increased lamp life which accompanies reduced voltage does not begin to compensate economically for the loss in light output. Maintenance of proper voltage is therefore an important factor in obtaining good performance from lamps operated on multiple systems. Characteristic curves for filament lamps operated on multiple circuits are shown in Fig. 2.

As an incandescent lamp burns, the filament gradually evaporates, or sublimates, thus decreasing the diameter of the filament. The normal end of life is reached when the wire breaks or burns through at its thinnest spot. A reduction in light output results from the absorption of light by the sublimated tungsten which collects as a black deposit on the inner surface of the bulb. The lumen maintenance of series lamps (operated at constant current) is better than that of lamps operated on multiple circuits, because the wattage of the multiple lamps (which are held at a constant voltage) gradually decreases throughout life, whereas the wattage of a lamp held at constant current increases with life. This is because the resistance of the filament wire increases as its diameter decreases due to evaporation. At constant voltage, increased resistance results in a

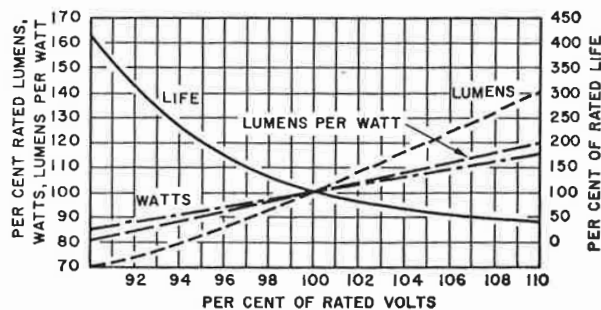

Fig. 2—Characteristic curves for incandescent lamps operated on a multiple circuit.

decrease in amperes, and accordingly, in watts. At constant current, increased resistance results in increased voltage, and a corresponding increase in watts which materially offsets the reduction in light output due to blackening of the bulb. Characteristic curves for series filament lamps are given in Fig. 3.

Fig. 4 shows two standard street-lighting luminaires that are commonly used with incandescent lamps.

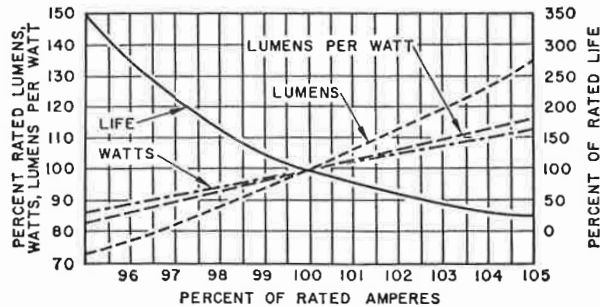

Fig. 3—Characteristic curves for incandescent lamps operated on a series circuit.

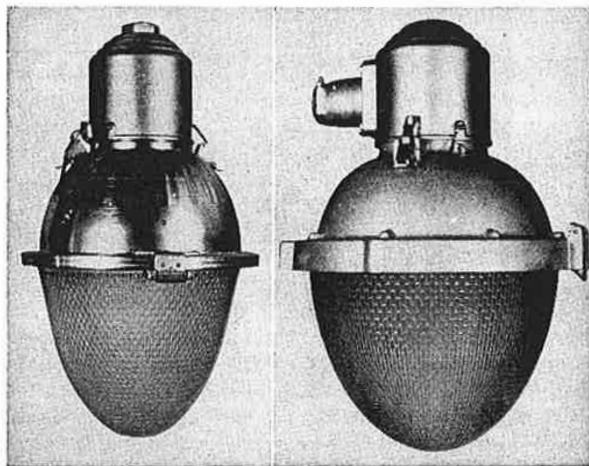

Fig. 4—Street-lighting luminaires designed for use with incandescent lamps, series or multiple, as well as type C-H5, F-H1, or E-H1 mercury lamps. (a) Type AK-10 for use with 2,500- to 10,000-lumen incandescent lamps. (b) Heavy-duty type AK-14 for use with 10,000- and 15,000-lumen incandescent lamps.

Mercury Lamps—Mercury lamps belong to the general classification known as electric-discharge lamps. In this type of lamp, light is produced by the passage of an electric current through a vapor or gas rather than through a tungsten wire. The application of an electric potential ionizes the gas and permits current to flow between two electrodes located at opposite ends of the lamp. The electrons, which comprise the current stream or “arc discharge”, are accelerated at tremendous speeds. When they collide with the atoms of the gas, or vapor, they temporarily alter the atomic structure. Light results from the energy given off as the disturbed atoms return to their normal state.

In mercury lamps, the “gas” utilized is vaporized mercury. Since mercury is a liquid at room temperature, a small amount of more readily ionized argon gas is introduced into mercury-vapor lamps to facilitate starting. The original arc is struck through the ionization of this argon gas. Once the arc strikes, the heat generated vaporizes the mercury. The electrodes used in mercury lamps are either of the activated type, with barium oxide as the electron-emissive material coated on a coil of tungsten wire, or of the non-activated thorium metal type. The impact of the arc heats the emissive material which supplies electrons to maintain the arc. The electrodes also act as terminals for the arc.

Mercury lamps are constructed with two bulbs: an inner bulb, or arc tube, which contains the arc, and an outer bulb which shields the arc tube from changes in temperature, and in some cases acts as a filter to remove certain wavelengths of the arc radiation. The outer bulb also carries the phosphor coating in fluorescent-mercury lamps. The arc tube is made of quartz in most lamps and of hard glass in a few of the older types. Quartz permits a more concentrated source of higher efficiency and also transmits the abundant ultraviolet radiation necessary for the fluorescent-mercury lamp. The outer bulb is of glass, the exact type determined by the application for which the lamp is designed, and the portion of the arc spectrum which it is desired to transmit. The space between the two bulbs is generally filled with inert gas.

Fig. 5 shows a number of mercury and fluorescent-mercury lamps designed for use in street-lighting luminaires.

The negative resistance characteristic of electric-discharge lamps makes it necessary to use a current-limiting device with these lamps. The device, or ballast, must provide the proper voltage to start the lamp and then limit the current through the lamp to the proper value.

Each ballast must be designed for the specific voltage, frequency, and lamp with which it will be used. An important advantage of mercury lamps is their ability to operate well over the range of input voltages for which the ballast was designed. Operation with input voltages above or below the ballast voltage range is not recommended. If the supply voltage is unusually low, the lamp may not start, or may require a longer time to warm up. When the supply voltage is too high, excessive lamp wattage may result. Fig. 6 shows the relationship of voltage, current, power, and light output for 400-watt E-H1 mercury lamps operated on typical ballasts.

The two-electrode type of mercury lamps requires starting voltages between 800 and 1200 volts to ionize the argon gas and permit the arc to strike. The more commonly used three-electrode type of lamp utilizes one electrode as a starting electrode. This starting electrode is placed close to the main electrode nearest the base of the lamp and makes it possible to start the lamp at a much lower voltage. The electrical field set up between these two electrodes causes an emission of electrons which develop a local glow and ionize the starting gas. The arc then starts between the two main elec-

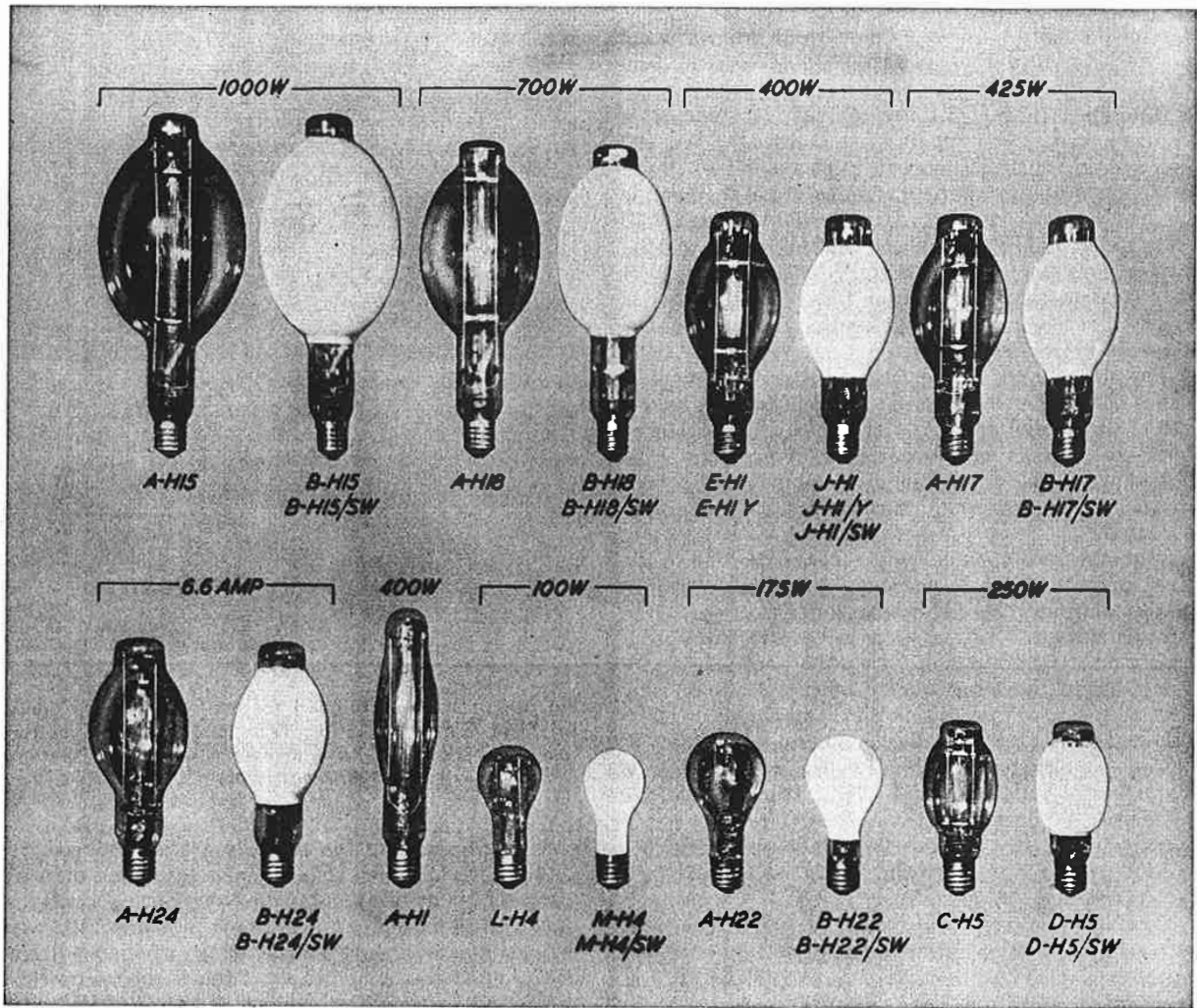

Fig. 5—Mercury and fluorescent-mercury lamps designed for use in street-lighting luminaires.

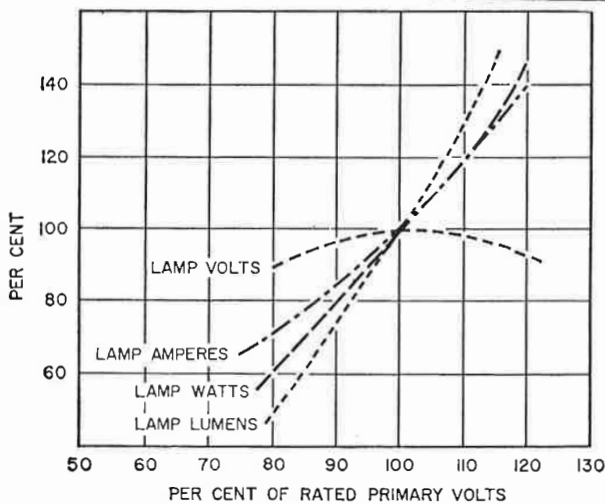

Fig. 6—Operating characteristics of 400-watt E-H1 mercury lamps with typical ballasts.

trodes, and the mercury gradually vaporizes and carries an increasing portion of the current. During this process, the arc stream changes from the diffuse bluish glow characteristic of the argon arc to the blue-green of mercury, increasing greatly in brilliance and becoming concentrated in the center of the tube. At the instant the arc strikes, the current is high and the voltage is low. Normal operating values are reached after a warm-up period of several minutes, during which time the current drops and the voltage rises until the arc attains a point of stabilization in vapor pressure.

An interruption in the power supply, or a sudden voltage dip of more than 15 to 30 per cent, may extinguish the arc. Before the lamp will re-light, it must cool sufficiently to reduce the vapor pressure to a point where the arc will restrike. During this time that the lamp is cooling, the ballast open-circuit or starting voltage is impressed on the lamp. The same condition exists when a lamp has failed or has been removed from the socket, except that a lamp replacement is necessary to

correct the condition. This is termed open-circuit operation of the ballast, and the line current drawn by the ballast is termed the open-circuit line current. This operating condition does not harm the ballast.

The lumen output of a new mercury or fluorescent-mercury lamp is abnormally high. During the first 100 hours of operation, the output drops about 5 to 10 per cent. The drop during the remaining life of the lamp is gradual, as shown in Fig. 7, for the 400-watt and 250-watt lamps. Published values for initial lumens are the values obtained after 100 hours of operation. The deterioration that occurs after the 100-hour point is chiefly due to a gradual blackening of the inside of the arc tube throughout its life.

The higher initial efficiency and higher intrinsic brilliance obtained with the quartz type of lamp is the result of the smaller size arc, which has higher loading in terms of wattage per square inch of arc tube. The larger arc-chamber used in glass lamps results in a somewhat slower drop in lumen output over the life of the lamp.

With the barium-oxide type of electrode used in the glass arc-tube lamps, both life and lumen maintenance of the lamp are affected by the number of times the lamp is started. Each time the arc is struck, some of emission material is removed from the electrodes and is deposited on the inner surface of the glass arc-tube. This process results in eventual exhaustion of the emission material and blackening of the arc-tube.

The thorium electrodes used in the quartz arc-tube lamps are so little affected by lamp starting that the same average rated life and lumen maintenance apply for operating cycles of either 5 or 10 hours per start.

Fig. 8 shows two luminaires designed for use with mercury lamps.

Fluorescent-Mercury Lamps—When an electric current is passed through vaporized mercury, the familiar blue-

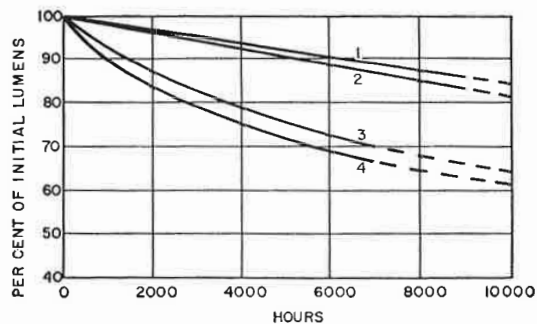

Fig. 7—Approximate lumen maintenance curves for several 400-watt mercury and fluorescent-mercury lamps.

Curve 1—Lifeguard lamps type E-H1-LG, P-H1-LG, P-H1/SW-LG, and P-H1/X-LG.

Curve 2—Lifeguard lamps type J-H1-LG, J-H1/SW-LG, J-H1/X-LG, K-H1-LG, and L-H1-LG.

Curve 3—Standard lamps type E-H1, E-H1-WD, P-H1, and P-H1/SW.

Curve 4—Standard lamps type J-H1, J-H1-WD, J-H1/SW, J-H1/SW-WD, K-H1, and L-H1.

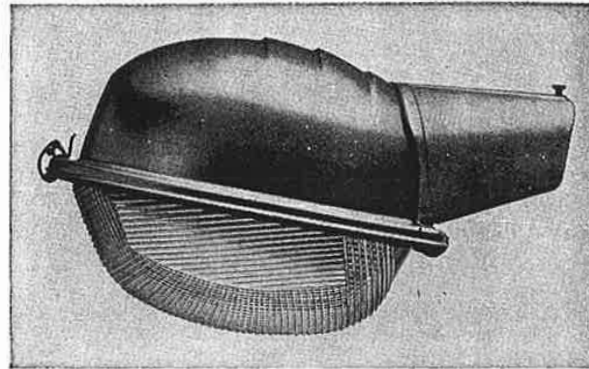

(a)

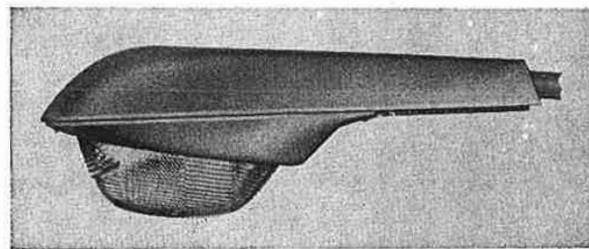

(b)

Fig. 8—Luminaires designed for use with mercury lamps. (a) Type OV-10 for 100-, 175-, and 250-watt mercury lamps. (b) Type OV-25 with built-in ballast for use with 400-watt, E-H1.

green-white light of the mercury arc is produced, together with a wealth of ultraviolet rays. The mercury arc can be controlled and made to produce a variety of bands of radiation. At low vapor pressures, the rays emitted consist almost entirely of the resonance line at 2537 Angstroms. An example of this is the bactericidal ray found in the Westinghouse STERILAMP which operates with a low vapor pressure of only a few microns. Westinghouse fluorescent lamps also operate at this low vapor pressure and use this radiation to excite the phosphor coating.

At medium vapor pressures, the radiations of longer wave lengths are strengthened, the energy emitted per inch of arc steam rises, and the increased energy in the visible lines results in high luminous efficiency. At higher vapor pressures, the color of the light becomes whiter, and the intensity of radiations emitted per inch of arc length rises so that these sources become invaluable where optical light control is required, such as in search-light or projection service.

In the fluorescent-mercury lamp the medium pressure is used. This produces high luminous efficiency plus large amounts of ultraviolet energy. The ultraviolet is utilized to cause the phosphor coating (magnesium fluorogermanate) on the inside of the outer bulb to fluoresce red. This red light, added to the natural blue-green-white of the mercury arc, produces a golden-white color of light. The color of this light is approximately the same as that obtained with a mixture of

equal wattages of mercury and incandescent lamps. Therefore, the use of a combination of mercury lamps and incandescent lamps to obtain white light is no longer necessary, and generally a system of fluorescent lamps is preferable.

Sodium Lamps—Sodium lamps are similar to mercury lamps in general principle, except that the arc is carried through vaporized sodium and the starting gas is neon. The vapor pressure at which the sodium arc operates is low, and the arc-tube must be enclosed in a vacuum flask to maintain the proper operating temperature. The starting time to full light output is 15 to 20 minutes, but the lamp will restart immediately after interruption of power supply.

The light produced by the sodium arc is almost monochromatic, consisting merely of a double line in the yellow region of the spectrum at 5890-96 Angstroms. Because all the energy emitted is so near the maximum of the eye sensitivity curve, efficiencies as high as 55 lumens per watt are obtained. The disadvantage of the limited spectrum is that all objects appear as yellow, or shades of yellow under the sodium lamp light. In addition, the large size and low brightness of the arc make accurate light control rather difficult.

The use of sodium lamps for street-lighting purposes never did gain great popularity in this country. Mercury and fluorescent lamps have practically eliminated the sodium lamp as a light source for street lighting. Sodium lamps are no longer stocked by any manufacturer and are available only on special orders of relatively large quantities.

Fluorescent Lamps—The fluorescent lamp is essentially an electric-discharge source. It consists of a tubular bulb with electrodes sealed into each end, and contains mercury vapor at low pressure with a small amount of argon for starting. The inner walls of the bulb are coated with fluorescent powders which give off light when activated by ultraviolet energy. When the proper voltage is impressed across the electrodes, a flow of electrons is driven from one electrode and attracted or pulled to the other. As the electrons move between the electrodes, they collide with the mercury atoms, causing a state of excitation which produces short-wave ultraviolet radiation (2537 Angstroms). The fluorescent powders, commonly known as phosphors, absorb this invisible energy and radiate visible light.

The type of electrode employed in most fluorescent lamps is the coated coiled-coil of tungsten wire. The coiled-tungsten-wire is coated with an emission material of barium and strontium oxide, which gives off emission because the electrons are emitted more as a result of the heat developed, than of the voltage applied. A hot spot is created on the cathode at the point where the mercury arc strikes, and a continuous stream of electrons is produced. This type of operation is characteristic of what is known as the "hot-cathode" lamp. As originally developed, it required a preheating of the cathodes to produce the necessary electrons to strike the arc. If a higher open-circuit voltage is applied to the lamp, the preheating of the cathode may be shortened as in the rapid-start type of lamp. If a still higher open-

circuit voltage is applied to the lamp, the lamp can be made to start instantly without preheating.

Like all electric-discharge lamps, fluorescent lamps must have a ballast to limit the current and, in most cases, provide the necessary starting voltage. Each lamp requires a ballast specifically designed for its characteristics and for the service voltage on which it is to be operated. The chief differences among ballasts lie in the open-circuit voltages supplied to the lamp. Lamps with preheat cathodes require relatively low starting voltages, not over 200 volts. Instant-start lamps require from 450 to 750 volts, and rapid-start types require from 450 to 550 volts.

The life of a fluorescent lamp is affected by the voltage, the current, and the number of times it is started. Electron emission material is lost from the electrodes continuously during the operation of the lamp, and in larger quantities each time the lamp starts. Since the end of life is reached when the emission material is completely consumed for one of the electrodes, the greater the number of burning hours per start, the longer the life of the lamp. When the emission material is exhausted, lamps on a preheat type of circuit will blink on and off as the electrodes heat but the arc fails to strike. Lamps designed for instant or rapid starting will simply fail to operate. Blinking lamps should be removed from the circuit promptly to protect both the starter and the ballast from overheating.

The light output of a new fluorescent lamp drops off about five per cent during the first 100 hours of operation. Since the depreciation after this initial drop is much more gradual, fluorescent lamps are rated at the end of the 100 hour period. A typical lumen maintenance curve for a fluorescent lamp is shown in Fig. 9. The depreciation in light output is due chiefly to a gradual deterioration of the phosphor powders, and a blackening of the inside of the tube. The blackening of the tube is produced by the electrode material deposited on the inner surface of the tube, and is therefore more pronounced at the ends of the lamp.

The voltage at the luminaire should be kept well

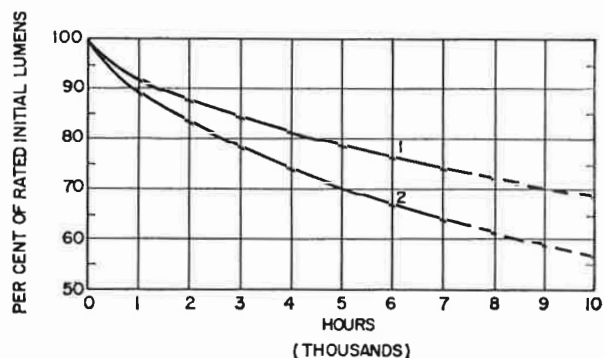

Fig. 9—Typical lumen maintenance curve of Westinghouse type HO and SHO fluorescent lamps normally used for street-lighting applications.

Curve 1—Medium loading of approximately 800 milliamperes.

Curve 2—Heavy loading of 1000 to 1500 milliamperes.

within the normal operating range for the ballast. Low voltage, as well as high voltage, reduces efficiency and shortens lamp life. This is in contrast with filament lamps, where low voltage reduces efficiency but prolongs the life of the lamp. Low voltage may also cause instability in the arc, and starting difficulty.

On voltages above the specified range, the operating current becomes excessive and may not only overheat the ballast, but may also cause premature end-blackening and early lamp failure. Voltages below the specified range may lower the preheat current to a point where the electrodes fail to emit a sufficient number of electrons to permit starting the lamp. If the lamps do start, the emission material may waste away too rapidly, with consequent shortening of lamp life.

Fig. 10 shows a four-tube fluorescent luminaire, with cover cutaway, that is used in applications where relatively high illumination levels are required. This unit is normally mounted perpendicular to the axis of the roadway. The luminaire shown in Fig. 11 is also used for high illumination levels, but this unit is mounted parallel to the axis of the roadway.

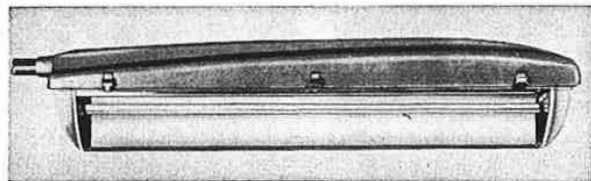

Fig. 10—Type 4FSL-72 fluorescent luminaire which uses four six-foot, 5300-lumen fluorescent lamps.

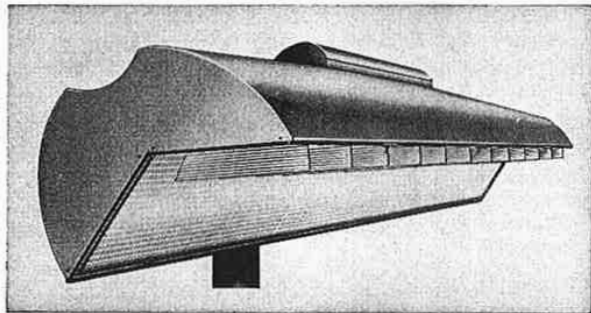

Fig. 11—Type 2HUS-72 "Mainstreeter" fluorescent luminaire which uses two six-foot, 5300-lumen fluorescent lamps.

II. SERIES SYSTEM

4. Description of Series System

As the name implies, all of the lamps in a series street-lighting system are connected in series in the lighting circuit. A constant current is maintained in the circuit, and consequently through all of the lamps, by means of a constant-current transformer.

Method of Supply—Two supply circuits are required for a series street-lighting system. One supply circuit is the high-voltage circuit for the constant-current transformer, and the other is the low-voltage circuit for the control circuit. The high-voltage supply is usually a single-phase tap from a primary feeder that exists in the area to be lighted. The low-voltage supply for the con-

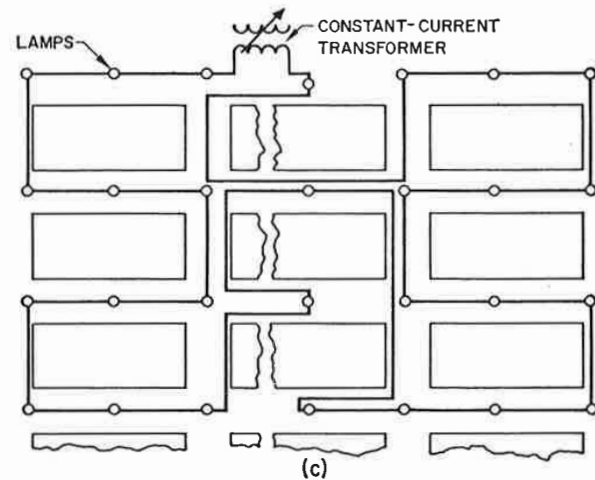
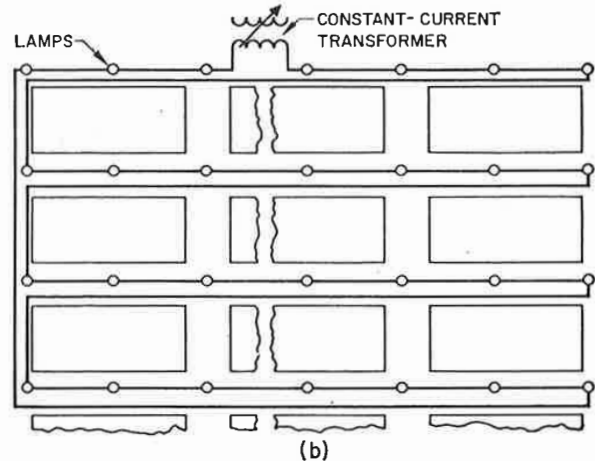
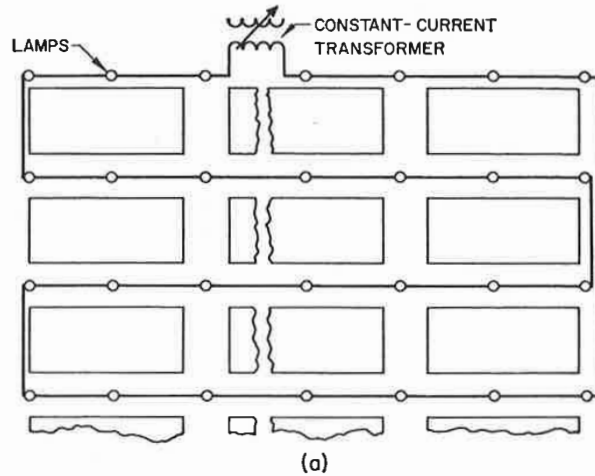

Fig. 12—Several possible series circuit arrangements to serve a given area. (a) Minimum conductor length—most difficult to test for open-circuit condition. (b) Maximum practical conductor length—easiest to test for open-circuit condition. (c) Compromise between conductor length and ease of open-circuit testing.

trol circuit is taken from a nearby 120/240-volt secondary circuit. If no secondary circuit exists close to the constant-current transformer location, a source of low-voltage supply for the control can be established through the installation of an instrument transformer or a distribution transformer having a relatively low kva rating.

Layout—Several simplified series street-lighting circuits are shown in Fig. 12. These different circuit arrangements illustrate the compromise that is made between circuit length and ease of testing under open-circuit conditions. Fig. 12(a) shows an arrangement that provides minimum conductor length but is very difficult to test for an open-circuit condition. Fig. 12(b) shows the other extreme, where testing is greatly simplified, but conductor length is at a maximum. Fig. 12(c) is a compromise between (a) and (b), in which the conductor length is greater than in (a), but less than in (b); and the ease of testing is better than in (a), but poorer than in (b).

The voltage drop across each lamp must be the rated voltage of the lamp in order to obtain rated lumen output. The voltage applied to the circuit must then equal the sum of the voltage drops across each of the lamps and the voltage drop in the circuit conductors. Consequently, the source voltage must be variable to permit variations in the number of lamps and in the length of the circuit. The voltage impressed upon the circuit by the constant-current transformers may vary from a few hundred volts to approximately 4500 volts, depending upon the number of lamps and the length of the circuit. However, when an open-circuit condition exists, the voltage can reach 6000 volts. The transformer automatically adjusts itself to maintain the desired current through the circuit for load conditions within its rated capacity. Changes in the impedance of the circuit due to lamp burnout, or extension of the circuit, are automatically compensated for by the constant-current transformer.

Where Applicable—The main area of application of series street-lighting systems is where illumination level requirements are relatively low and luminaires are relatively far apart. For the most part, this is brought about by the savings that can be made through the use of small conductors at the high voltage. Series systems are used almost exclusively in areas where secondary distribution circuits are not available, such as on parkways, highways, and in rural areas. Series street-lighting applications also predominate in residential areas.

The use of a series system is more attractive to operating companies if they are operating series systems and do not have to change the inventory of street-lighting equipment maintained in stock. Significant savings are available if local regulations and code do not require that insulating transformers be used with each luminaire. Another factor that indicates that series circuits probably should be used in expanding street lighting is that a considerable amount of constant-current transformer capacity is available. Having personnel available that are qualified to operate and maintain the high-voltage series systems is also important.

Limitations—Series street-lighting circuits are generally not used in commercial areas where secondary circuits exist at almost all points where a luminaire might be installed. This is particularly true in areas where secondary-network systems exist.

The main disadvantage of the series street-lighting circuit is that high voltages are present in the case of an open-circuit condition unless a series transformer is used. In addition to presenting a safety hazard to maintenance personnel, this results in increased investment in equipment that must withstand these high voltages.

5. Selection of Current Rating

Current Ratings Available—Series street-lighting circuits have constant-current ratings of 3.3, 6.6, 7.5, 15, and 20 amperes. The most commonly used of all of these constant-current ratings are the 6.6-ampere and the 20-ampere ratings.

The 6.6-ampere rating is a carry-over from the days of the magnetic-arc lamps. The 6.6-ampere constant-current transformers used for the arc lamps were standard equipment, and filament lamps were designed for use with these transformers.

The 7.5-ampere rating is also a carry-over from the days of the arc lamp. However, the 7.5-ampere rating makes up only a very small percentage of all installations.

The 15-ampere and 20-ampere ratings came into use through several advantages that they offer over the 6.6-ampere rating. First of all, in most cases the size of the circuit conductors in a series circuit is determined by the mechanical strength of the conductor. This means that the current-carrying capacity of the conductor used for a 6.6-ampere circuit is considerably in excess of the current that it has to carry. The 15- and 20-ampere circuits permit taking better advantage of the current-carrying capacity that is available in the conductor. Another advantage of the higher amperage circuits is that the circuit voltage is reduced to approximately one-third that of a 6.6-ampere circuit. Or, looking at it another way, for the same maximum voltage at either 6.6 amperes or 20 amperes, the number of lamps in a 20-ampere circuit may be approximately three times the number on a 6.6-ampere circuit.

The 3.3-ampere rating has come into use with mercury lamps. The 6.6- and 20-ampere rating had been very nearly standardized upon by the time that the mercury lamps were introduced. Since each mercury lamp type required a different operating current, it became common to restrict the open-circuit voltage at the luminaire through the use of a two-winding current transformer with an air gap in the core. The one type of mercury lamp that predominates among the mercury installations requires 3.3 amperes. Since this condition has come about, a 3.3-ampere constant-current system has been developed to use these lamps. This system eliminates the use of a small current transformer or series-mercury transformer at each lamp, but requires the use of a non-standard constant-current transformer for the lighting circuit.

There are a number of factors that influence the decision as to which of the current ratings is to be used in a

new installation. Established practice is usually the determining factor. However, when future planning is taken into account, the continuation of existing practice may not be the most economical answer.

Local codes, safety to maintenance personnel, and local rates for street lighting also influence the choice of current rating for a series circuit.

6. Description of Equipment for Series System

Fig. 13 shows in detail the equipment used in a series street-lighting circuit. At the left of the figure are the two sources of supply that serve the system. The primary feeder tap supplies power for the lights, and the 120-volt tap supplies power to the control circuit.

Constant-Current Transformers—To obtain full or rated lumen output from the lamps in a series street-lighting circuit, the current flowing through the lamps must not be lower than the rated current of the lamps. To avoid serious reduction in lamp life, the current must not be allowed to increase above the rated value. Therefore, it is desirable that a current equal to the rated current of the lamps flow in the circuit, regardless of the number of lamps on the circuit or the length of the circuit.

Since electric energy is generated at constant potential, these series systems require an intermediate device to transform the energy from a constant potential to a constant current. The device which is economical and most desirable, because it gives the closest current regulation for all loads, is the moving-coil constant-current transformer. These transformers are designed to convert a constant-potential value (ranging from 2.4 kv to 13.2 kv) to a constant-current value of 3.3, 6.6, 7.5, 15 or 20 amperes.

The early constant-current transformers were all of

the air-cooled, open-construction design for indoor applications. Since most of the early street-lighting circuits originated at an attended station, the constant-current transformer could conveniently be installed indoors. Increased use of street lighting made it necessary to develop oil-insulated, pole-type, and subway-type units that could be installed throughout the system. Present day pole-type units are available with added built-in features for complete protection against lightning, against faults in the primary winding, and against open-circuit conditions on the lighting circuit.

The discussion given below describes the theory and principles of operation of constant-current transformers. In particular, this discussion refers to the open station-type unit. While the construction of the pole- and subway-types of constant-current transformer are slightly different, the same theory of operation applies to each type.

The constant-current transformer is a two-winding transformer with one coil which is movable with respect to the other. The movable coil is balanced by a counterweight, and its position is determined by the electromagnetic force between the coils.

In Fig. 14(a) and (b), *P* is the primary coil, *S* is the secondary coil, *W* is the wheel or lever arrangement used to suspend the moving coil, and *C* is the counterweight. Assume that a voltage is applied to *P* while the circuit of *S* is open. An exciting current will flow and a magnetic flux will be induced through the primary coil and up the middle leg of the iron to the top. Here the total flux will divide, and one-half will return down each of the outer legs to the primary coil. The amount of flux through *P* is determined from the transformer formula, $E = (k) (f) (A) (N) (B)$; where *E*=voltage, *k*=a con-

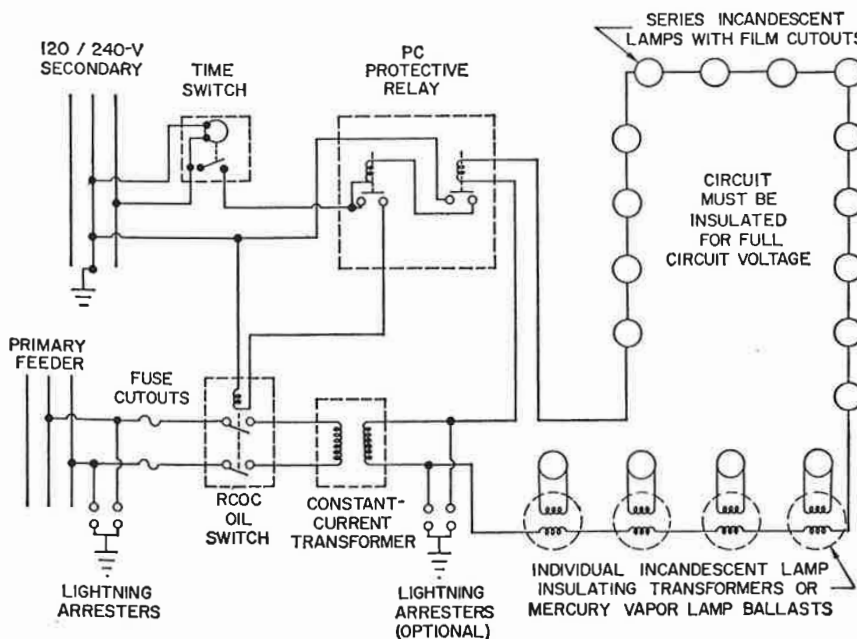

Fig. 13—Schematic diagram of a series street-lighting circuit.

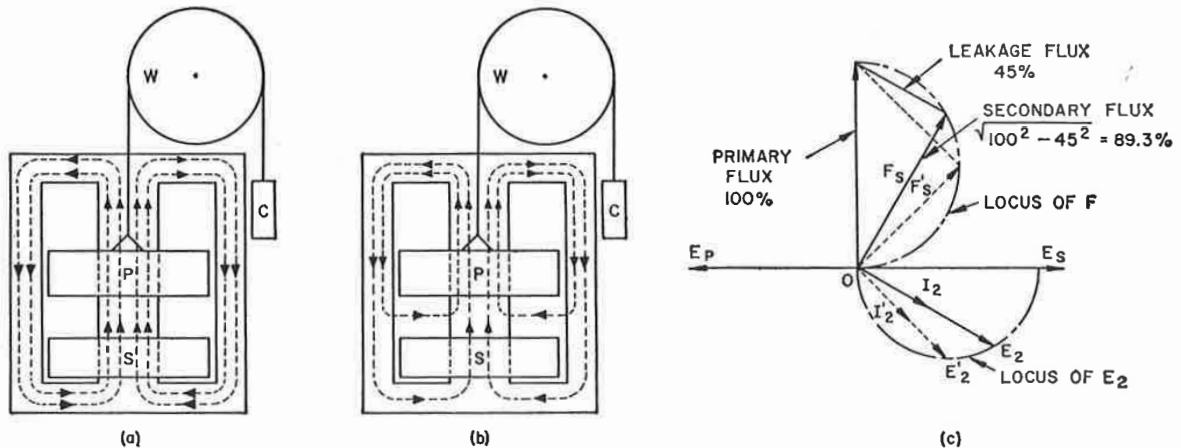

Fig. 14—Magnetic circuit and flux path of a movable-coil constant-current transformer. (a) With secondary open. (b) With secondary closed through load circuit. (c) Vector diagram of primary and secondary voltages and flux with secondary closed through load circuit.

stant, A = area of core, N = number of turns, B = flux density, and f = the frequency in cycles per second.

The flux in the iron induces a voltage in the secondary coil, and, if the circuit is completed, a current will flow. The current in S sets up a magneto-motive force opposed to that of P , and a part of the magnetic flux through P will be forced across the opening between P and S , instead of following the iron circuit. This has two results. First, the voltage in S will be reduced because of the reduced flux which links it; and second, there will be an electromagnetic force on P tending to raise it. This force is caused by the reaction of the leakage flux on the current in S . The counterweight is normally adjusted so that the weight of the coil is just equal to the counterweight plus the electromagnetic force when the coil is carrying the desired current.

If a part of the load is suddenly short-circuited, there will be an instantaneous rise in the secondary current, and consequently in the leakage flux. This results in an increased force between coils, and the primary coil moves upward. The leakage space between the coils is thus increased, and the secondary voltage is diminished to a point where it will again send only the desired current through the circuit.

The relation of the various quantities is shown by the vector diagram, Fig. 14(c). For the sake of simplicity, the losses in the transformer are neglected, and it is assumed that the secondary load has a power factor of 100 per cent. If OE_p is the voltage applied to the primary coil, OF will be the flux which links this coil. OE_s , exactly opposite to OE_p , would be the voltage induced in the secondary if there were no magnetic leakage—that is, if the secondary coil were open circuited. At full load on the secondary, there will be a normal leakage between the primary and the secondary amounting to 45 per cent of the primary flux, more or less; and since this leakage flux is in phase with the secondary current, it will be perpendicular to the flux through the secondary coil, which produces the secondary voltage. Therefore, on OF as a hypotenuse,

construct a right triangle with one side equal to 45 per cent of OF , and the other side equal to $\sqrt{100^2 - 45^2} = 89.3$ per cent of OF . OF_s is the flux which induces the secondary voltage, and it leads the secondary voltage by 90 degrees. The secondary voltage at the load is OE_2 , and the secondary current will be in phase with OE_2 , since the load power factor is 100 per cent.

If a part of the load is short-circuited, the coils will move apart as explained above. This will cause the vectors to take the position shown by the dotted lines, increasing the leakage flux and decreasing the flux through the secondary coil, with a consequent reduction of the secondary voltage. The secondary current is thus brought back to its normal value. Constant-current transformers are usually designed so that, with normal voltage and frequency on the primary, and with the secondary short-circuited, normal secondary current will not quite cause full separation of the coils.

It is interesting to trace the effect of a change in the primary voltage or frequency when the secondary load is not changed. An increase in the primary voltage will cause an increase in the primary flux. Since the secondary flux remains the same for the same load, the coils move apart so as to increase the per cent leakage. This lowers the primary power factor. It may also cause an increase in the short-circuit current of the secondary coil if the moving coil reaches the top of the opening.

An increase in the primary frequency, without a corresponding change in voltage, decreases the primary flux. The secondary flux decreases in the same proportion. The leakage flux also decreases in the same proportion, and the coils therefore must move closer together. The frequency can be varied only within rather narrow limits without changing the voltage. If it becomes too low, the magnetic density in the iron becomes too high. If the frequency is too high, the per cent leakage becomes high and the transformer has reduced capacity and poor power factor.

The primary windings of constant-current transformers are usually provided with taps, and, from what

has gone before, it will be easy to see the effect of using the taps. If 2200 volts is applied to the 2400-volt connection on the transformer, the volts-per-turn, and consequently the flux through the primary coil, is decreased. For any given output therefore, the coils are closer together, the leakage is less, and the power factor is higher. If 2600 volts is applied to the 2400-volt connection, the effect is the reverse. For a given output, the coils are farther apart, and, if the secondary is short circuited, there may be a rise of current because the coils may not be able to move far enough apart.

The current regulation of a constant-current transformer is quite accurate. The moving parts are supported on ball bearings and, if the transformer is mounted reasonably level so that the coil travels freely, the current should not vary more than one per cent from its rated value.

This type of transformer cannot be overloaded, because the secondary current will decrease if the load capacity of the regulator is exceeded. The no-load condition corresponds to a short-circuit on the secondary load terminals and, under this condition, the position of the movable coil approaches that of maximum separation. At full load, the coils are at nearly minimum separation. If the load is increased beyond the full-load value, the coil separation is further decreased until the bumper-stop is reached. Beyond this point, any increase in load will result in a corresponding decrease in secondary current.

Because of the constant-current characteristic, the I²R loss in this type of transformer remains constant for all load values, but the stray loss increases with a decrease in load. Consequently, the total loss increases with decrease in load and is maximum at no-load. The operating temperature is therefore lower when operating at nearly full load than when operating at only a fraction of the full-load rating.

The constant-current transformer will operate correctly as long as the variation in the primary supply voltage is not greater than five per cent above or below the rated tap voltage, and provided the secondary is not loaded above the rated load for the particular transformer. For example, the 4800-volt tap accommodates voltages ranging from 4560 volts to 5040 volts. A 4320-volt tap on the transformer provides for voltages ranging from 4100 volts to 4540 volts.

There are two basic types of pole-type constant-current transformers and one subway-type which are manufactured by Westinghouse. These units are available in standard kw ratings of 10, 15, 20, 25, and 30 kw with single-voltage primaries for 2400, 4800, or 7200 volts, and dual-voltage primaries for either 2400 or 4800 volts. The standard rated current for the secondary windings of constant-current transformers are 6.6 or 20 amperes. These units are designed in accordance with AIEE, ASA, and EEI-NEMA Standards, and, in line with these standards, deliver rated output at secondary terminals to a 99½ per cent power-factor load at 95 per cent of rated primary voltage. Temperature rise in the windings does not exceed 55C above a 40C ambient temperature when operated at 50 per cent of rated load

for eight hours. These transformers have 48 per cent minimum inherent impedance to prevent excessive current inrush to the lamps when the circuit is energized. The transformers are subjected to the dielectric tests given in Table 4.

Table 4—Constant-Current Transformer Dielectric Tests

Rated Circuit Voltage In Volts	Impulse Test Full Wave Crest-Kv	60 Cycle Test-Kv
2400/4160Y	60	19
4800/8320Y	75	26
4800/2400	75	26
7200/12470Y	95	34

The pole-type CPH constant-current transformer shown in Figs. 15 and 16 has the operating characteristics outlined above. The type CPH transformer with cover-mounted bushings is available with primary voltages from 7200 volts through 13.2 kv. It is not available with primary voltages below 7200 volts, nor with lightning arresters. The type CPH transformer with wall-mounted bushings and de-ion arresters provides protection against lightning surges between the primary and core or tank, between the secondary and core or tank, and between the primary and secondary windings.

The pole-type CSPH constant-current transformer is a self-contained "package unit" that includes an oil switch, a type PC protective relay, de-ion arresters,

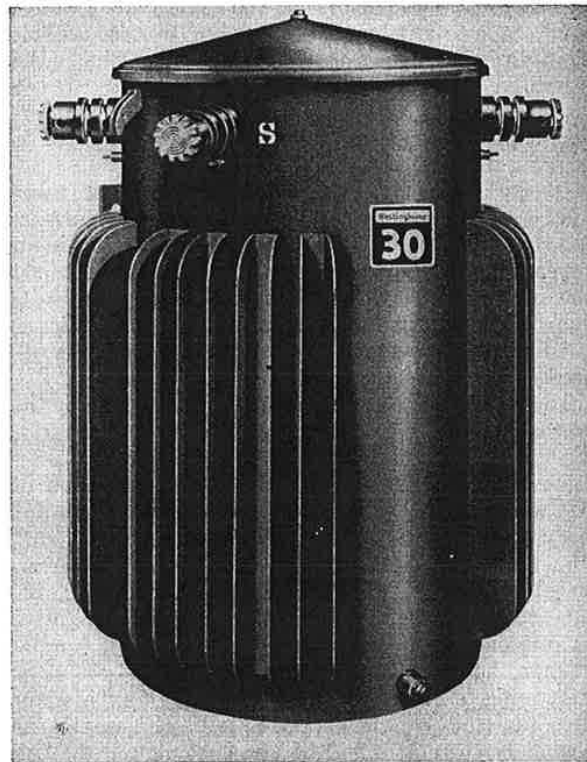

Fig. 15—Westinghouse pole-type CPH constant-current transformer for series street-lighting circuits.

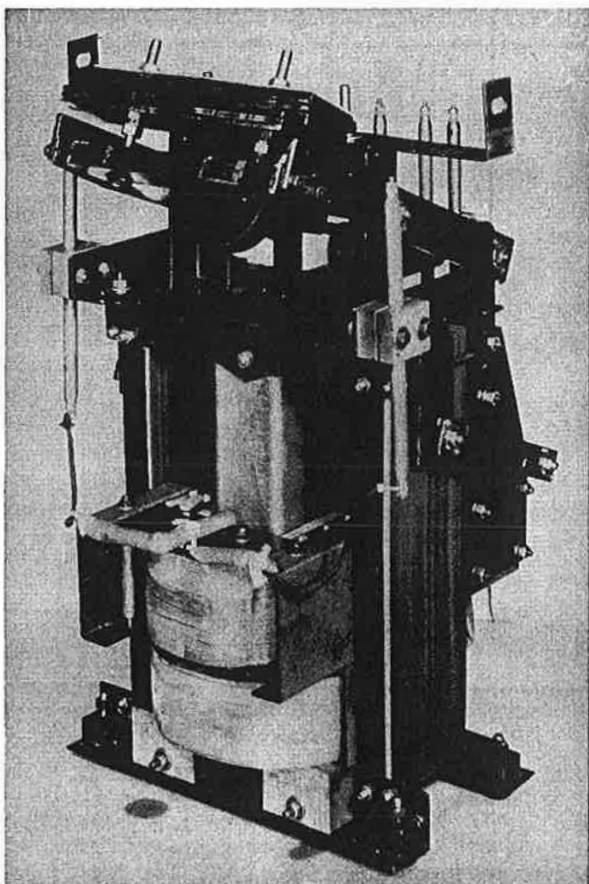

Fig. 16—Core and coil assembly of Westinghouse pole-type CPH constant-current transformer.

fusible protective links, and the core and coil assembly, housed in one tank.

The type CSPH transformer is also available with shunt capacitors mounted externally on the tank to correct the normal power factor to a high power factor for all conditions of load within the capacity and rating of the unit. This unit is designated as type CSPH-C. The type CSPH-K differs from the CSPH unit in

that it includes a series-cascade controlled oil switch and protective relay. This unit is designed specifically for series-cascade installations.

The subway-type constant-current transformer, designated type CMH, is a waterproof unit designed for operations in vaults and manholes.

Table 5 gives the electrical characteristics and performance data for all of the pole-type constant-current transformers described above, with the exception of the CSPH-C unit. The same type of information for the CSPH-C unit is given in Table 6.

Circuit Switch and Controls—Lamps on series street-lighting circuits are turned on and off through the action of a switch in the high-voltage circuit that supplies the constant-current transformer. The switching operation may be initiated by any one of several types of controls available. The type of control used will depend upon the location of the street-lighting circuit, the specific purpose of the lights, the time cycle of operation for the lights, etc. Among the most common control methods are manual control, time switches, and photoelectric cells. A discussion of the characteristic and operation of these controls appears elsewhere in this chapter.

The switch used to energize or de-energize the constant-current transformer can be almost any type of air or oil circuit breaker, as long as the switch selected has the necessary voltage, current, and interrupting ratings. This is particularly true if the street-lighting circuits terminate at an attended substation and the circuit is switched manually. Most circuits, however, are remote from an attended substation and remote switching is necessary.

The most common type of switch for remote operation is a pole-mounted, two-pole, oil-filled switch.

Schematic diagrams of the type RCOC oil switch are shown in Fig. 17. The diagram in Fig. 17(a) has a shunt operating coil rated at 120 volts at 60 cycles. This coil is energized from the low-voltage supply circuit through the circuit control. The diagram in Fig. 17(b) is for a switch used in a series-cascade circuit arrangement. Instead of a 120-volt coil, this switch has a 6.6-ampere constant-current coil which is energized from a 6.6-ampere series street-lighting circuit.

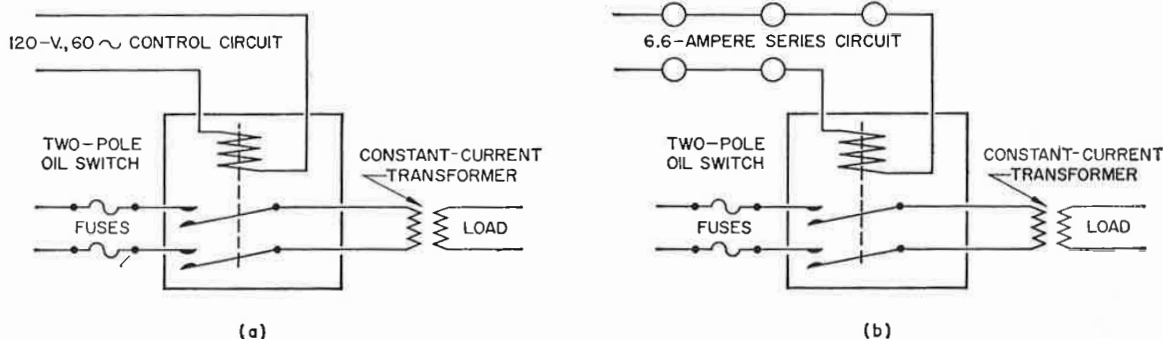

Fig. 17—Schematic diagram of two types of RCOC oil switches. (a) Switch with control circuit energized from 120-volt circuit. (b) Switch with control circuit energized from 6.6-ampere series street-lighting circuit for cascade operation.

Table 5—Electrical and Performance Data For All Westinghouse Pole-Type Constant-Current Transformers Except Type CSPH-C

Kw Rating	Approx. Primary Amps. at All Loads	Approx. Kv-a Input at All Loads	Secondary Open Circuit Voltage	Secondary Normal Load Voltage	Approx. Max. Output at Unity Pf-Kw	Efficiency▲				Primary Power Factor (%)			
						Full Load	¾ Load	½ Load	¼ Load	Full Load	¾ Load	½ Load	¼ Load
2400 VOLTS PRIMARY - 6.6 AMPERES SECONDARY													
10	5.87	14.1	2090	1515	11.30	95.1	93.5	90.4	82.2	75	56	38	20
15	8.75	21.0	3090	2270	16.95	95.8	94.3	91.7	84.3	75	56	38	20
20	11.6	27.8	4090	3030	22.6	96.2	95.0	92.5	85.9	75	56	38	20
25	14.4	34.6	5110	3790	28.3	97.0	95.9	93.7	87.5	75	56	38	20
30	17.3	41.5	6130	4550	33.9	97.0	96.0	93.9	88.5	75	56	38	20
2400 VOLTS PRIMARY - 20 AMPERES SECONDARY													
10	5.87	14.1	690	500	11.30	95.1	93.5	90.4	82.2	75	56	38	20
15	8.75	21.0	1020	750	16.95	95.8	94.3	91.7	84.3	75	56	38	20
20	11.6	27.8	1350	1000	22.6	96.2	95.0	92.5	85.9	75	56	38	20
25	14.4	34.6	1690	1250	28.3	97.0	95.9	93.7	87.5	75	56	38	20
30	17.3	41.5	2020	1500	33.9	97.0	96.0	93.9	88.5	75	56	38	20
4800 VOLTS PRIMARY - 6.6 AMPERES SECONDARY													
10	2.93	14.1	2090	1515	11.30	95.1	93.5	90.4	82.2	75	56	38	20
15	4.37	21.0	3090	2270	16.95	95.8	94.3	91.7	84.3	75	56	38	20
20	5.80	27.8	4090	3030	22.6	96.2	95.0	92.5	85.9	75	56	38	20
25	7.20	34.6	5110	3790	28.3	97.0	95.9	93.7	87.5	75	56	38	20
30	8.65	41.5	6130	4550	33.9	97.0	96.0	93.9	88.5	75	56	38	20
4800/2400 VOLTS PRIMARY - 6.6 AMPERES SECONDARY													
	4800 Volts	2400 Volts											
10	2.93	5.87	2090	1515	11.30	95.1	93.5	90.4	82.2	75	56	38	20
15	4.37	8.75	3090	2270	16.95	95.8	94.3	91.7	84.3	75	56	38	20
20	5.80	11.6	4090	3030	22.6	96.2	95.0	92.5	85.9	75	56	38	20
25	7.20	14.4	5110	3790	28.3	97.0	95.9	93.7	87.5	75	56	38	20
30	8.65	17.3	6130	4550	33.9	97.0	96.0	93.9	88.5	75	56	38	20
7200 VOLTS PRIMARY - 6.6 AMPERES SECONDARY													
10	1.96	14.1	2090	1515	11.30	95.1	93.5	90.4	82.2	75	56	38	20
15	2.92	21.0	3090	2270	16.95	95.8	94.3	91.7	84.3	75	56	38	20
20	3.86	27.8	4090	3030	22.6	96.2	95.0	92.5	85.9	75	56	38	20
25	4.80	34.6	5110	3790	28.3	97.0	95.9	93.7	87.5	75	56	38	20
30	5.77	41.5	6130	4550	33.9	97.0	96.0	93.9	88.5	75	56	38	20

▲Conventional efficiency based on I²R loss at 75°C and measured core loss at normal primary voltage with secondary open.

Table 6—Electrical and Performance Data For Westinghouse Pole-Type CSPH-C Constant-Current Transformers

Kw Rating	Approx. Primary Amps. at Full Load	Approx. Primary Kv-a Input at Full Load	Secondary Open Circuit Voltage	Secondary Normal Load Voltage	Approx. Max. Output at Unity Pf-Kw	Efficiency (%)♦				Primary Power Factor (%)▲			
						Full Load	¾ Load	½ Load	¼ Load	Full Load	¾ Load	½ Load	¼ Load
2400 VOLT PRIMARY - 6.6 AMPERES PRIMARY													
15	6.58	15.8	3090	2270	16.95	95.8	94.3	91.7	84.3	100	98	89	64
20	9.13	21.9	4090	3030	22.6	96.2	95.0	92.5	85.9	-97	100	99	92
25	10.8	26.0	5110	3790	28.3	97.0	95.9	93.7	87.5	100	98	89	64
30	13.0	31.1	6130	4550	33.9	97.0	96.0	93.9	88.5	100	98	89	64
4800 VOLT PRIMARY - 6.6 AMPERES SECONDARY													
15	3.29	15.8	3090	2270	16.95	95.8	94.3	91.7	84.3	100	98	89	64
20	4.56	21.9	4090	3030	22.6	96.2	95.0	92.5	85.9	-97	100	99	92
25	5.40	26.0	5110	3790	28.3	97.0	95.9	93.7	87.5	100	98	89	64
30	6.50	31.1	6130	4550	33.9	97.0	96.0	93.9	88.5	100	98	89	64

♦Conventional efficiency based on I²R loss at 75°C and measured core loss at normal primary voltage with secondary open.

▲As corrected with capacitors.

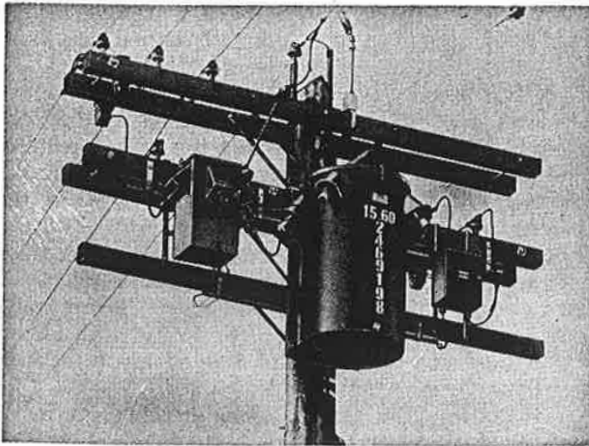

Fig. 18—Series street-lighting installation showing a type AN oil switch, a constant-current transformer, and a type PC protective relay.

A typical pole-type installation of an oil switch, a constant-current transformer, and a protective relay are shown in Fig. 18.

Standard oil switches have interrupting ratings of 50 amperes at 2500 volts, 35 amperes at 5000 volts, and 15 amperes at 7500 volts line-to-line, for use on 5.0/8.66-kv systems, and for line-to-neutral supply of an 8.66/15-kv wye class system. Other ratings are available, but the above ratings are the most commonly used. All units have auxiliary hand levers for manual operation.

In the case of the type CSPH constant-current transformers, the switch is included as an integral part of the packaged unit and is located in the same tank with the transformer. A wiring diagram of these packaged units is shown in Fig. 19 for both the 120-volt control and the series-cascade control.

Film Cutouts—Film cutouts are used with individual lamps in series circuits to insure continuity of the circuit after a lamp failure. The film cutout is inserted between the series socket prongs of the series luminaire. This puts the cutout in parallel with the lamp. At volt-

ages somewhat higher than the normal lamp voltage, the cutout acts as an insulator. Upon failure of the lamp, it breaks down at a value below the open-circuit voltage of the line.

Film cutouts are an important connecting link in the system, and their failure to operate properly may cause expensive and serious lamp outages, possible damage to equipment, and both radio and telephone interference due to harmonic voltages.

For correct operation, the film cutout must function in the following manner:

1. It shall break down immediately upon failure of the lamp filament (due to burnout or mechanical damage), and insure continuity of the circuit by short circuiting the socket prongs.

2. The short-circuit established by the film cutout shall be positive and permanent. Its current-carrying capacity should be sufficient to avoid excessive voltage drop, thus eliminating unnecessary line losses, radio and telephone interference, and overheating of the socket and receptacle.

There are three different film cutouts that are used in series circuits. They are designated as low-voltage, intermediate-voltage, and medium-voltage film cutouts. The low-voltage and intermediate-voltage cutouts consist of two thin aluminum discs, three-quarters of an inch in diameter, which are separated by means of a thin asbestos washer. The hole in the center of the asbestos washer is filled with finely divided aluminum powder. The aluminum discs and the asbestos washer are firmly cemented together.

The medium-voltage film cutout consists of two aluminum discs coated on the inside with a mixture of graphite and aluminum powder. The discs are firmly cemented to an asbestos washer, which acts as a heat-resisting spacer.

Table 7 gives the area of application of these three types of film cutouts.

Conductors—Weather-proof conductors are normally used on overhead series street-lighting circuits. Bare conductors may be used where local codes permit, and where sufficient spacings between street-lighting circuits and primary feeder circuits are practical to avoid

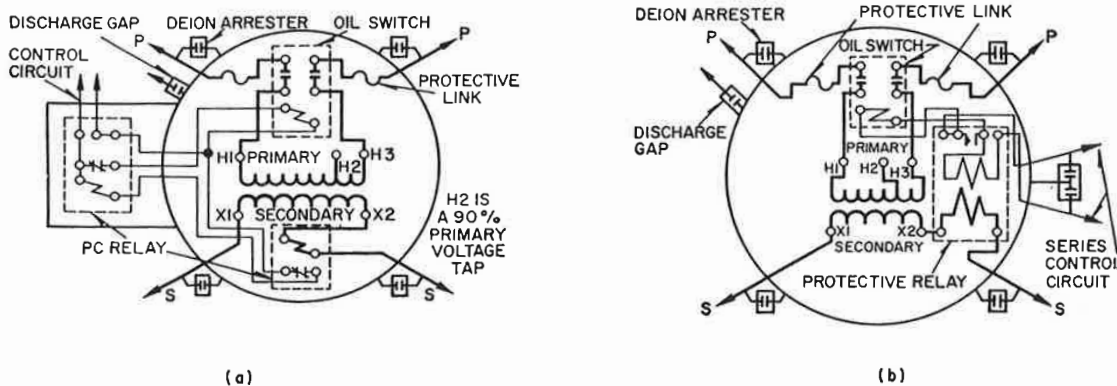

Fig. 19—Schematic diagram of two types of packaged unit constant-current transformers. (a) Type CSPH constant-current transformer with 120-volt control circuit. (b) Type CSPH-K constant-current transformer with control circuit that is directly in series with a series lighting circuit supplied from another transformer.

Table 7—Application of Film Cutouts for Incandescent Lamps Used With or Without Insulating Transformers

Film Cutout Designation	Breakdown Voltage In Volts			Lamp Rating	
	Min.	Max.	Avg.	Lumens	Amperes
Low (L)	40	100	60	1000	6.6
				1000	7.5
				2500	15.0
				4000	15.0
				4000	20.0
Intermediate (B)	75	150	100	6000	20.0
				2500	6.6
				2500	7.5
				4000	6.6
				4000	7.5
				10000	20
Medium	100	400	250	15000	20
				6000	6.6
				6000	7.5
				25000	20

contact between the conductors. Since the current flowing in a series circuit is relatively low, the conductor size is usually determined by mechanical strength. In most cases, No. 8 or No. 6 copper conductors are used.

The selection of conductors for use in underground lighting circuits is somewhat complicated by the fact that these conductors may be installed in duct banks with distribution circuits, in separate ducts, or directly buried in the earth.

In the downtown areas of large cities, the distribution system is normally underground with the cables installed in multiple duct banks. In many cases, there are spare ducts available that can be used solely for street-lighting circuits. Practice over the years has been to install varnished-cambric, paper, or rubber-insulated cable with lead sheath in these ducts. The grounding of the sheath and the wiping of all splices and terminations have given this type of cable an excellent operating record. In recent years there has been an increase in the use of synthetic materials in this type of application, with rubber-insulated neoprene-jacketed cables also giving excellent performance.

A survey of utility practice, where separate conduits are used for street-lighting circuits, shows that the large majority of companies prefers rubber or rubber-like insulation covered by a neoprene jacket. Single-conductor No. 8 or No. 6 with 5-kv insulation is usually used.

Direct burial of cables for street-lighting service presents a few problems that are not present when ducts are used. The cables are usually more exposed to mechanical damage, plus the fact that when a fault occurs it usually costs more to locate and eliminate the trouble. For these reasons, many companies use lead-covered cables or parkway-type cables to minimize troubles. In many cases, the use of rubber-neoprene cables with or without some mechanical protection above the cable is believed to be adequate for this type

of installation. Single-conductor No. 8 or No. 6 copper cables are normally used for directly-buried circuits.

7. Cascading

Description—Series-cascading of street-lighting circuits is accomplished by inserting the control relay of one constant-current transformer into the load circuit of another constant-current transformer. When the parent circuit is energized, the control in the load circuit closes and energizes the cascaded circuit. A third circuit can be controlled by putting its control in the load circuit of the first cascaded circuit. Theoretically, any number of circuits could be controlled in this manner by inserting the control of each circuit in the load circuit of the adjacent cascaded circuit.

Application—This type of street-lighting control is used primarily where economy can be achieved through elimination of time-clock or photo-electric control for the new circuits.

Cascading has a definite disadvantage in that each cascaded circuit is dependent upon all of the circuits between it and the parent control. If there were a fault in any of these circuits, or if any control relay failed to close, then all of the cascaded circuits beyond the trouble spot would not be energized.

Constant-Current Transformers—The type CSPH-K constant-current transformer is designed for installations where it is preferable to use an existing, conveniently located series-lighting circuit to control the operation of the primary oil switch in order to obtain an identical switching schedule for the new series circuit.

Fig. 19(b) shows the schematic wiring diagram of the CSPH-K constant-current transformer. The series control circuit of the CSPH-K is inserted in the load circuit of the controlled series circuit. When the controlled series circuit is energized, the series control in the CSPH-K causes the series-cascade controlled type AN oil switch to operate to close the primary circuit of the constant-current transformer.

8. Protection

Open-Circuit Protection—It is necessary to provide protection against the hazards of open-circuit voltage on a series-lighting circuit. The type PC series open-circuit relay provides this protection. The constant-current transformer regulates the voltage across the secondary terminals to give rated constant current in the connected series lamp circuit. Should a conductor break, or a film cutout fail to breakdown upon lamp failure, full open-circuit voltage is established across the break or across the lamp, as the case may be. The value of the open-circuit voltage is proportional to the transformer constant-current and kw rating. (See tables 5 and 6.) The type PC protective relay operates to de-energize the operating coil of the normally-open remote control oil switch and thus disconnects the primary of the constant-current transformer when open-circuit conditions exist in the series lamp circuit.

The type PC protective relay has internal connections as shown in Figs. 20 and 21. Under normal circuit conditions, the air dashpot delays action of the control

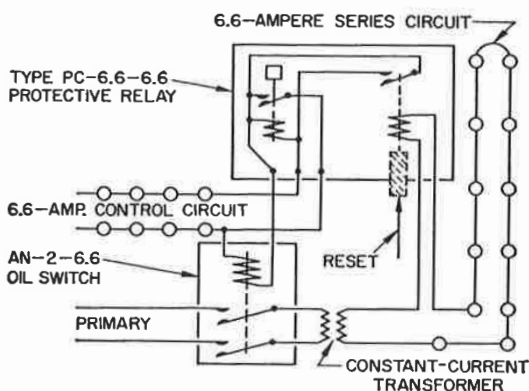

Fig. 20—Connections for type PC-6.6-6.6 protective relay with 6.6-ampere series control circuit rating and a 6.6-ampere series protected circuit rating.

circuit element for one-half second. This delay permits the series-protected circuit element to actuate contacts to de-energize the coil of the control circuit element. Normal operation requires only 40 volt-amperes continuous power to the series-protected circuit coil. An open-circuit fault de-energizes the series-protected circuit relay coil, which actuates contacts to energize the coil of the control circuit element. The control circuit element de-energizes the primary oil switch operating coil to disconnect the connected load. The type PC protective relay series-circuit operating coils are insulated for series-lighting circuits on which the open-circuit voltages do not exceed 8000 volts.

Lightning Protection—Series street-lighting circuits in most areas are generally well shielded by buildings, structures, and other electrical circuits, and as a result are not subject to much trouble caused by lightning strokes. For this reason, there is not much operating experience with lightning arresters applied to series street-lighting circuits. Practice with respect to lightning protection of street-lighting circuits trends toward minimum protection, unless operating experience indicates otherwise.

When a direct stroke hits a series street-lighting cir-

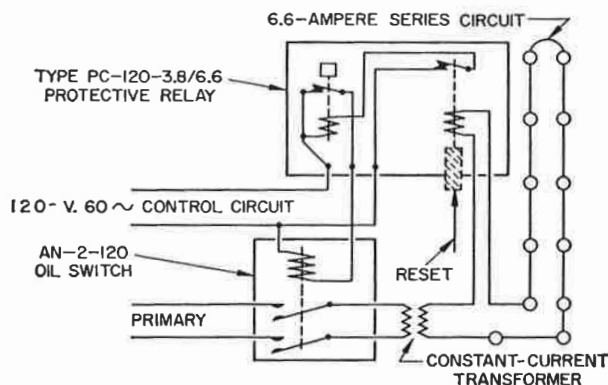

Fig. 21—Connections for type PC-120-3.8/6.6 protective relay with 120-volt, 60-cycle control circuit rating and 3.8/6.6-ampere series protected circuit rating.

cuit, there generally is a flashover at one of the insulators or at the porcelain socket of one of the lamps. Therefore, the surge current usually travels for only a short distance along the circuit. It is possible that, if a flashover occurs at a luminaire socket, the lamp involved will burn out.

When direct strokes to the street-lighting circuit do occur frequently, as indicated by excessive lamp failures or breakdown of film cutouts, there are several steps that can be taken. The most effective protection for exposed series circuits is to run a grounded shield wire over the entire length of the circuit. This protects all lamps in event of a direct stroke, but is more expensive than applying a few lightning arresters to confine outages to four or five lamps. On these exposed circuits, it is recommended that standard type LV lightning arresters be placed on the lines at a distance of approximately 1500 feet from the regulator. If lamp or film cutout failures are excessive, additional lightning arresters can be added along the line.

Constant-current transformers of the CSP type are equipped with type LXT lightning arresters. For constant-current transformers that are not of the CSP type, it is recommended that either type LXT or LVT arresters be applied.

Transformers with a single-circuit secondary require two arresters for the secondary. An arrester should be applied to each line on the primary side of the regulator. These arresters should be located on the source side of the oil switch and the power-factor correcting capacitor, if one is used. In selecting the proper voltage rating of arresters for the primary circuit, consideration should be given to the circuit voltage and normal arrester application procedure should be followed. Under certain conditions on grounded-neutral systems, it is desirable to apply grounded-neutral arresters having an 80 per cent rating, since these arresters will provide a greater margin of protection.

The recommended ratings for lightning arresters applied to the secondary circuits of constant-current transformers are based on the open-circuit voltage. Recommended arrester ratings for 6.6-ampere and 20-ampere series circuits are given in Table 8.

9. Grounding

The high voltages used in series street-lighting circuits present a possible hazard to the public and maintenance personnel in the case of failure of insulation somewhere on the system. For this reason, it is recommended that all equipment cases, tanks, housings, metallic poles, and conduits be effectively grounded. The frame and one of the secondary conductors of an insulating transformer should also be grounded, if the secondary is to be treated as a low-voltage circuit.

Since the current is limited in a series street-lighting circuit, grounding conductors generally are not subjected to a current flow of more than about 20 amperes. Therefore, the mechanical strength of the conductor becomes the determining factor, and conductor sizes ranging from No. 8 to No. 4 copper are normally used.

Table 8—Recommended Lightning Arrester Ratings for 6.6-Ampere and 20-Ampere Series Street Lighting Circuits

KW Rating of Regulator	Arrester Maximum Rating In Kv	
	6.6-Ampere Secondary	20-Ampere Secondary
2	0.50	0.50
3	0.75	0.50
5	3.0	0.50
7½	3.0	0.75
10	3.0	0.75
15	3.0	3.0
20	6.0	3.0
25	6.0	3.0
30	6.0	3.0
40	9.0	3.0
50	12.0	6.0
60	12.0	6.0
70	15.0	6.0

In many cases where series circuits are underground, an intentional ground is established at the electrical midpoint of the circuit. This effectively reduces the normal stress on the insulation to one-half of the normal load voltage of the constant-current transformer. If an open-circuit condition occurs on a circuit grounded in this manner, the cable on the ungrounded side of the open point is subjected to full open-circuit voltage to ground. If an open-circuit protective relay is used with the transformer, the duration of the overvoltage is in the order of less than a second. If the protective relay is not used, the cable is subjected to the open-circuit voltage until the situation is recognized and corrected. This may be a matter of hours, or even days.

Some companies place an intentional ground on the circuit at or near one of the transformer terminals. This has the advantage of making it convenient to remove the ground for test purposes, but, at the same time, it increases the normal stress on the conductor insulation near the other terminal of the transformer.

When an accidental ground occurs on a series circuit on which an intentional ground exists, the portion of the circuit between the two grounds is essentially shorted out, and the lamps go out or burn dimly. This condition gives an excellent indication as to the location of the accidental ground point.

While a large number of series circuits are operated with intentional grounds, probably the majority of the series circuits are ungrounded. This is true of both overhead and underground circuits. The ungrounded circuit will continue to operate with one accidental ground.

III. MULTIPLE SYSTEM

10. Description of System

Voltages—In a multiple street-lighting system, the lamps are served over low-voltage circuits, as opposed to the high-voltage circuits used in the series system. The most common multiple system voltages are 120/240 volts, single-phase, three-wire, or 120 volts, single-

phase, two-wire. Systems operating at 120/208 volts, three-phase, four-wire are used in some commercial areas and 480-volt systems are becoming popular.

Layout—The multiple system may take several forms. Because low-voltage secondary circuits exist in the great majority of the areas where street lights are installed, individual multiple lamps can be supplied directly from the existing secondaries. When this type of system is used, each lamp requires an individual control. In another form of the multiple system, a separate secondary circuit is installed for the sole purpose of serving multiple street lights. The power supply to this secondary circuit is accomplished by one of two methods. See Fig. 22. Both methods utilize standard, pole-type distribution transformers and may use the same type of control for switching intelligence.

The difference between the two methods lies in the actual switching. In one method, the primary of the distribution transformer is directly connected to the available primary circuit, and the switching operation is performed by a multiple relay that is located between the secondary terminals of the transformer and the multiple circuit. In the other method, the secondary of the distribution transformer is directly connected to the multiple circuit, and the switching is performed by an oil switch on the primary side of the transformer.

Advantages—Multiple street-lighting applications are increasing, due to a number of advantages that they offer. In new areas where street lighting has not existed, the individually controlled multiple units eliminate the need for a separate system in addition to the distribution circuits. The fact that the lamps operate at low-voltage makes them safer to maintain and does not require maintenance personnel who are qualified to work on high-voltage circuits. The equipment used for the multiple system is essentially the same as used on other distribution circuits. All of these factors usually add up to a cost advantage over series street-lighting circuits.

Limitations—Multiple street lighting also has some disadvantages that should not be overlooked. The main disadvantage of multiple circuits which are separate from the low-voltage distribution circuits is that large conductors must be used when long circuit runs or large loads are involved. The installed cost of these conductors becomes an important factor in the overall economics.

11. Description of Equipment for Multiple Systems

Transformers—One of the big advantages of the multiple system is that standard pole-type distribution transformers are used. This makes it possible and practical to install a multiple lamp or lamps on existing low-voltage secondary circuits without having to install additional transformer capacity, in the great majority of cases. However, since there will be a number of days during the year when the street lights will be on at time of peak load on the distribution transformers in some areas, the street-lighting load must be taken into account in determining the necessary distribution transformer capacity.

Another advantage of the use of standard pole-type

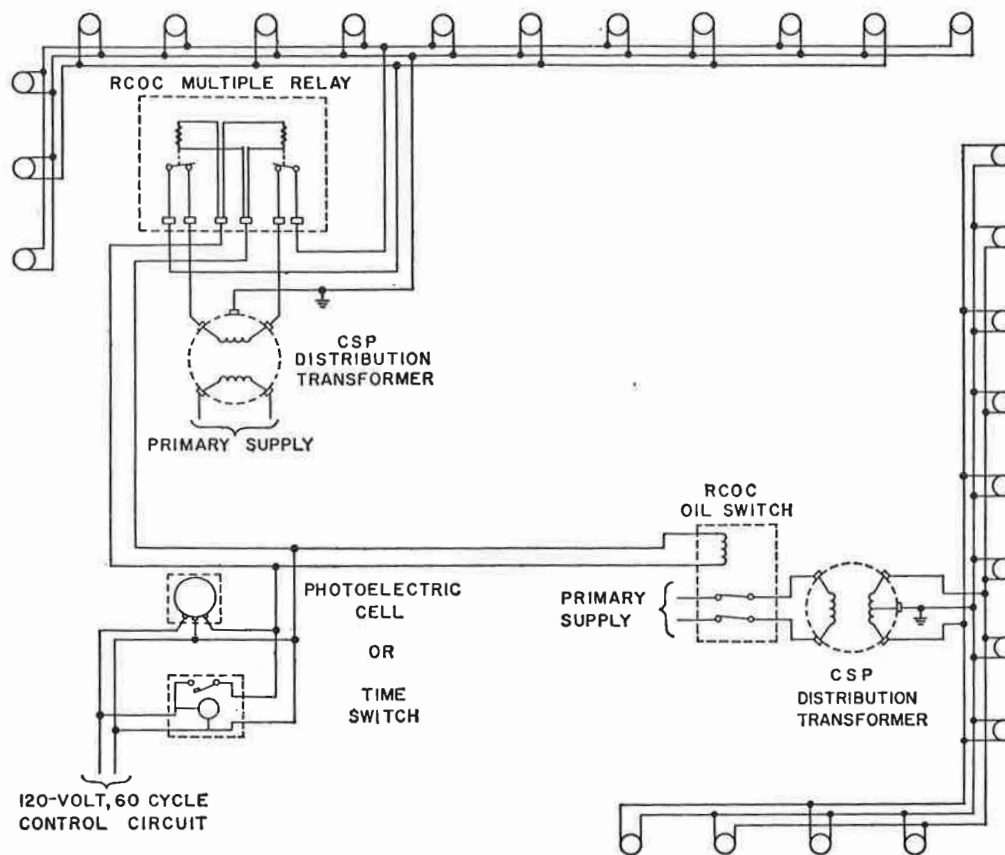

Fig. 22—Two different methods of serving multiple street lighting circuits. In one method the switching is accomplished on the high-voltage side of the distribution transformer, and in the other the switching is performed at low voltage.

distribution transformers and the multiple system concerns the starting requirements of mercury lamps. In series systems it is sometimes necessary to install the constant-current transformer on the basis of the starting requirements of the mercury lamps, rather than on normal operation requirements. This results in two disadvantages. One is the relatively high investment in constant-current transformer capacity. The other is the resulting low power factor operation of the transformer, due to the fact that under normal operation the load on the transformer is well below its rated output. This usually indicates that the installation of shunt capacitors on the primary side of the constant-current transformer is necessary.

The thermal capabilities of standard distribution transformers are such that the high starting currents drawn by the mercury lamps usually do not present a problem. At least, in the majority of cases, the starting requirements of mercury-vapor lamps on multiple systems do not necessitate more transformer capacity than needed for normal operation.

The fact that standard pole-type distribution transformers are used for multiple systems somewhat simpli-

fies the problems of planning, ordering, and stocking transformers to serve street-lighting systems.

Circuit Switch—When the switching of multiple circuits is accomplished by switching the primary supply to the transformers, the type R-C-O-C oil switch is normally used. Automatic switching with this device is accomplished by energizing the control circuit to the 120-volt, 60-cycle, shunt operating coils of the switch with a low-voltage time switch or photoelectric control.

The operating characteristics of R-C-O-C oil switches for multiple system applications are given in Table 9, and the interrupting ratings are given in Table 10.

All of the switches listed in these two tables have an auxiliary hand lever on the tank, with the exception of the type CP oil switch. This lever permits manual or automatic operation of the switch. When the hand lever is set in the AUTO position, energizing the control circuit either opens or closes the switch load contacts, as indicated in Table 10.

When multiple circuit switching is accomplished by switching the circuit on the low-voltage side of the supply transformer, the type MR multiple relay is used. The load contacts of the multiple relay are actuated by

Table 9—Operating Characteristics of R-C-O-C Oil Switches For Multiple Street Lighting Applications

R-C-O-C	Coil Rating	Pull-In Voltage in Volts	Maximum Drop-Out Voltage in Volts	In-rush Amperes	Continuous Current Rating in Amperes	Voltage Rating in Volts
AN	120-volt, 60-cycle	90	65	5.0	1.5	120
ANH	120-volt, 60-cycle	90	65	5.0	1.5	120
ANR	120-volt, 60-cycle	95	65	7.3	3.7	120
CP	120-volt, 60-cycle	90	70	12.0	1.4	120
CPM	120-volt, 60-cycle	90	70	12.0	1.4	120

energizing the control circuit to the relay operating coil. The operating characteristics of the multiple relays are given in Table 11. The load contacts of the type MR multiple relay are normally open with the operating coil de-energized. The type MRR multiple relay contacts are normally closed with the operating coil de-energized. This relay is usually specified for applications requiring positive control of the 'ON' schedule, as a fault in the control circuit will de-energize the relay operating coil and close the load contacts.

In areas where there are a number of multiple circuits using low-voltage switching, a single time clock or photo-electric control can be used to energize a large number of type MR multiple relays.

Ballasts—A ballast is required to start and operate a mercury lamp on a multiple street-lighting system. The ballast is used to provide the higher voltages re-

Table 10—Interrupting Ratings of the Type R-C-O-C Oil Switches for Multiple Street Lighting Applications

R-C-O-C Type	R-C-O-C Specification Number	Number of Poles	Amperes at Line-to-Line Voltage			
			15000 Volts	7500 Volts	5000 Volts	2500 Volts
CONTACTS NORMALLY OPEN WITH 120-VOLT, 60-CYCLE COIL DE-ENERGIZED						
AN-1-120	6120 ⁺	1	—	15	35	50
AN-1-120	6122 ⁺	1	—	15	35	50
AN-2-120	6121 ⁺	2	—	15	35	50
AN-2-120	6123 ⁺	2	—	15	35	50
CONTACTS NORMALLY CLOSED WITH 120-VOLT, 60-CYCLE COIL DE-ENERGIZED						
ANR-1-120	6130 [*]	1	—	—	35	50
ANR-2-120	6131 [*]	2	—	—	35	50
CONTACTS NORMALLY OPEN WITH 120-VOLT, 60-CYCLE COIL DE-ENERGIZED						
CP-2-120	6091 ⁺⁺	2	10	20	30	60
CP-3-120	6059 ⁺	3	—	20	30	60
CPM-2-120	6092 ⁺⁺	2	10	20	30	60
CPM-3-120	6069-A ⁺	3	—	20	30	60
CPM-3-120	6075-A ⁺	3	—	20	30	60

⁺Recommended for phase-to-neutral switching applications on an 8.66/15-Kv system.
^{*}Recommended for phase-to-neutral switching applications on a 5.0/8.66-Kv system.
⁺⁺Recommended for use on an 8.66/15-Kv system.

Table 11—Operating Characteristics of R-C-O-C Multiple Relays with 120-Volt, 60-Cycle Coils

R-C-O-C Type	Number of Poles	Load Rating in Amperes	Pull-In Voltage in Volts	Maximum Drop-Out Voltage in Volts	Inrush Amperes Rating	Continuous Power	
						Current Rating in Amperes	Watts
MR	1	15	75	65	.140	.055	4
MR	1	30	85	70	.310	.080	6
MR	1	60	85	70	.800	.160	12
MR	2	30	85	70	.620	.160	12
MRR	1	15	75	65	.115	.055	4
MRR	1	30	80	65	.285	.080	6
MRR	1	60	80	65	.850	.160	12
MRR	2	30	80	65	.570	.160	12

quired for starting, and to limit the current flow once the arc has been established.

The "reactor" type of ballast may be used to limit the flow of current in the lamp. This type of ballast, which is a simple inductance, is used where the voltage of the multiple circuit is correct for starting the lamp.

Where the circuit voltage is not correct for starting the lamp, an autotransformer is included in the ballast to provide the proper voltage. This type of ballast is called a "high-reactance" ballast.

The reactor type and high-reactance type of ballasts are recommended for use on multiple circuits where the line voltage available at the ballast does not vary more than ± 5 per cent from the rated top voltage. Where the ballast will be subject to greater voltage variations, the "regulated-output" ballast should be used. This ballast is of recent design and is a variation of the high-reactance type of ballast. It incorporates a saturable iron element and will operate the lamp over a 12 or 13 per cent voltage variation on multiple circuits. Another advantage of this regulated-output type of ballast is that there are no voltage taps to complicate their installation on the system.

While it is not essential for proper operation, most reactor and high-reactance ballasts contain a capacitor to correct the input power factor to 90 per cent or more. The normal power factor for an uncorrected ballast is approximately 50 to 60 per cent. All regulated-output ballasts have a power factor of 95 per cent or above, since a capacitor is an essential part of their design.

The starting and operating characteristics of mercury lamps are quite different from those of incandescent lamps. The line starting current for each type of lamp and ballast will vary in maximum value as well as in duration. It may vary from less than normal to 75 per cent greater than normal for different lamp-ballast combinations.

In general, the higher the ratio of secondary short-circuit current to lamp operating current, the shorter is the lamp starting time for a given type of lamp. The high-pressure, short-arc lamps usually reach stable operating conditions faster than the longer-arc lamps.

Conductors—When multiple street lighting is used in overhead distribution areas, existing secondary circuits may be used as the source of power supply to the lamps. In the great majority of cases where existing secondaries are utilized, the lengths of the secondaries are usually only three or four pole spans long. This limits the number of lamps per secondary to a small number, due to physical spacing of the lamps. As a result, the fact that the lamps are supplied directly from the secondary has little or no influence in the determination of secondary conductor size.

When separate circuits are used for multiple street lighting, it is to be expected that the conductor runs will be relatively long, taking transformer-secondary combination economics into account. Voltage drop normally determines the conductor size for a given circuit length and number of lamps.

There is a definite trend to the use of rubber or rubber-like insulation with neoprene or comparable jacket in multiple circuits that are installed underground. The cable normally used for multiple circuits has insulation rated for 600 volts and below.

In the downtown areas of cities, these cables are normally installed in available ducts. These cables should not be in the same duct with high-voltage cables.

In residential areas, underground multiple circuits are normally buried directly in the ground without the use of duct or mechanical protection. Burial depth varies between one and two feet. Ducts are normally used with direct-buried installations where the cables pass under streets and sidewalks.

The conductors used in underground circuits normally range from No. 8 to No. 2 copper.

12. Protection

The problem of providing protection for multiple street-lighting circuits is simpler than for series circuits. The main reason for this is that the low-voltage multiple circuits are not exposed to as much possible trouble as series circuits are. The multiple circuits are not on the same crossarm with primary distribution circuits, and consequently are not subject to contact with those conductors due to wind and trees. The fact that the multiple conductors are installed below the primary circuits affords them shielding from lightning strokes.

If CSP distribution transformers are used to supply multiple circuits, overload and fault protection are provided by the secondary breakers in the transformers. The lightning arrester on the transformer provides protection against surges on the primary circuit which might get into the secondary. If conventional distribution transformers are used, the same degree of protection cannot be provided as with the CSP transformer. Lightning arresters and primary fuse cutouts are normally installed with the conventional transformers.

IV. SERIES-MULTIPLE SYSTEM

13. Description of Series-Multiple System

Where Applicable—In cases where a new group of street lights are necessary in an area served by series

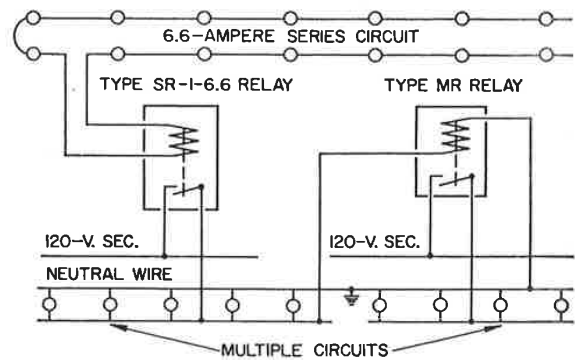

Fig. 23—A series-multiple street-lighting system using a type SR-1-6.6 series-multiple relay to switch the multiple lamps, and a type MR multiple relay to switch additional multiple lamp groups.

street-lighting circuits, a series-multiple system arrangement may be used. The decision to use the series-multiple system may be based on one or more of several reasons. Most series-multiple systems are used because the existing series circuits do not have sufficient capacity to handle the additional load. Assuming, that the lighting schedule for the series circuit is satisfactory for the multiple circuit, a series-multiple relay is inserted in the series circuit to control the multiple lamps. When the series circuit is energized, the series-multiple relay operates to actuate a contactor, or pilot-wire control, to energize the multiple lamps. The supply circuit to the multiple lamps may be a tap off of an existing secondary circuit, or may be a separate circuit with its own distribution transformer.

The decision to use the series-multiple arrangement may also stem from the fact that the use of high-voltage circuits is undesirable in the new installation. It may also be used to eliminate the cost of control in a multiple system, or to eliminate the cost of a constant-current transformer in a series system.

Layout—Two possible circuit arrangements for series-multiple systems are shown in Fig. 23 and Fig. 24. In Fig. 23, the type SR series-multiple relay closes its normally-open contacts when the 6.6-ampere series circuit

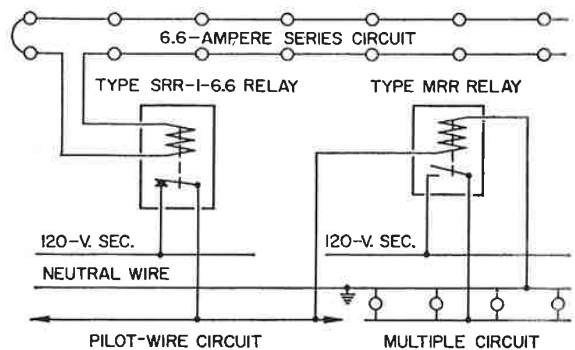

Fig. 24—A series-multiple street-lighting system using a type SRR-1-6.6 series-multiple relay to initiate pilot wire switching through the use of a type MRR multiple relay.

is energized. When the relay contacts close, the multiple circuit is energized from the 120-volt supply circuit. Other multiple circuits may also be controlled from the one series-multiple relay through the use of type MR multiple relays as shown. In Fig. 24, the type SRR series-multiple relay opens its normally-closed contacts when the 6.6-ampere series circuit is energized. This operation de-energizes the pilot-wire circuit and causes the type MRR relay to close its contacts and thereby energize the multiple lamps.

Limitations—The series-multiple system has the same major disadvantage of the series-cascade system, in that a failure in the series system or in the series system control will prevent energization of the multiple lamps.

14. Description of Equipment for Series-Multiple System

The series-multiple system provides a convenient means of using a series-lighting circuit to control a multiple lighting circuit requiring an identical lighting schedule. With the exception of the series-multiple relay used to tie the series system to the multiple system, the equipment used in the series system and the multiple system is the same as used in other series and multiple systems.

Series-Multiple Relays—Series-multiple relays are basically a solenoid-actuated contactor. They may be single or two pole devices, and may be either normally open or normally closed with the coil de-energized. Series-multiple relays are available with either 6.6-ampere or 20-ampere coil ratings and either 125- or 250-volt load ratings. Table 12 gives the designation and ratings of series-multiple relays.

Table 12—Series-Multiple Relay Ratings

R-C-O-C Type	Number of Poles	Coil Rating in Amperes	Normal Contact Position	Load Rating Per Pole	
				Amperes	Volts
SR-1-6.6	1	6.6	Open	40	125
SR-1-20	1	20	Open	40	125
SR-2-6.6	2	6.6	Open	20	250
SR-2-20	2	20	Open	20	250
SRR-1-6.6	1	6.6	Closed	40	125
SRR-1-20	1	20	Closed	40	125

V. STREET-LIGHTING CONTROL

15. Manual Controls

Street lights are turned on and off through the use of several types of controls. The oldest, and simplest, control scheme employs manual control. Manual control dates back to the early days of electric street lighting when all lighting circuits originated at attended stations. Circuits are still switched manually today at attended substations. However, the extensive street-lighting systems of today have made remote controls necessary and, for the most part, have eliminated manual controls. The relatively low cost and the reliability of modern remote controls make it difficult to justify manual switching in some attended stations where street-lighting circuits originate.

16. Photo-electric or Light-sensitive Controls

There are three general types of light-sensitive devices used to control street lights. One type utilizes a photo-tube, an amplifier tube, a time-delay network, a power tube, and a relay or contactor. A second type employs a self-generating, or photo-voltaic, photocell of the barrier-layer cell type, a relay, a small motor, and a sealed mercury switch. The third type has as its primary features a broad-area cadmium sulfide photoconductive cell and a special full-wave rectifier type relay.

The phototube type requires from 3.5 to 11 watts during the daytime and from 1.5 to 7 watts during the night. The barrier-layer cell type draws no current between turn-on and turn-off operations. Each complete on-off cycle of operation requires only 4 watts for one minute, generally once a day. The cadmium sulfide type of control requires a maximum of 0.9 watt in the daytime and a maximum of 0.6 watt at night.

The phototube type of control is available in two ratings with respect to the contacts. Contact ratings are 575 watts and 3000 watts. The 575-watt rating is used for single-lamp control, or for control of a pilot-wire control circuit. The 3000-watt rating is used to control a group of lamps. The mercury switch in the barrier-layer cell type of control is rated 30 amperes at 120 volts. The cadmium sulfide control is rated for a maximum direct lamp load of 1000 watts.

These controls are normally aimed to the north, and are preset to turn on and off based on the illumination of the north sky. The control can be adjusted to turn the lights on over a range of 0.5 to 5.0 foot-candles.

Care must be exercised in the installation of these light-sensitive devices so that artificial light of an intensity above the turn-on value will not strike the light-sensitive cell. This would prevent the desired operation of the control.

The phototube type of control has a time-delay circuit which provides a four to six second delay at turn-off. This prevents false operation of the control due to transient lights, such as from the headlamps of passing automobiles.

From the standpoint of having street lights turned on when they are needed, the light-sensitive type of control provides the best operation. The curve in Fig. 25 shows the turn-on and turn-off characteristics of photoelectric lighting controls.

When light-sensitive controls are used to control mercury- or sodium-vapor lamps, it is recommended that the turn-on setting be increased by 4.0 or 5.0 foot-candles. This will cause the lamps to be energized about 7 or 8 minutes earlier, thus insuring that the lamps will be up to full brilliance when natural daylight has dropped to one foot-candle.

The greatly increased use of multiple circuits has also increased the use of photoelectric type controls. The economics of using this type of control, along with the economics and flexibility of the multiple system, have made it practical for some operating companies to standardize on the use of multiple circuits with an individual control for each lamp.

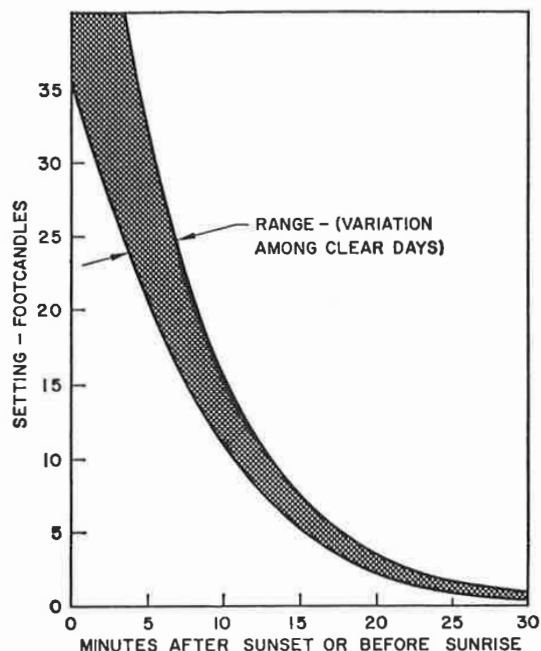

Fig. 25—Approximate relationship between the operating points of a photo-electric lighting control in foot-candles and either the turn-on in minutes after sunset or the turn-off in minutes after sunrise on a clear day.

17. Time-Clock Controls

Time-clock controls offer one of the least expensive methods of controlling street lights. The basic time-clock unit consists of an astronomical-dial clock driven by a synchronous motor, and a set of contacts. This type of clock automatically adjusts the contact operations to meet the day-to-day variations in sunrise and sunset.

One major disadvantage of this type of control is that outages on the circuit supplying power to the clock will cause the clock, and consequently the street light operation, to be off schedule. This problem can be avoided, at least for outages of short duration, through the addition of a mechanical timer that will continue to operate the clock until electric power is restored. The addition of the mechanical timer makes the control more complex and of course increases the cost, but, it does eliminate the necessity of having to reset time clocks following an extended service outage.

Time clock controls can be used for either series or multiple circuits to good advantage.

18. Pilot-Wire Control Systems

One of the most common methods of controlling street lights has been accomplished through the use of an a-c pilot-wire system. As the name pilot wire implies, a wire is run from a master control to each lamp or group of lamps to be operated from the master control. The master control can be a time clock, a light-sensitive device, or manual control. The pilot wire itself is usually

a No. 8 or No. 6 conductor. A relay is installed at each lamp, or group of lamps, to be operated. The relays may be operated in one of two ways. The most popular operation is to energize the pilot wire and the relays in the daytime. De-energization of the pilot wire and the relays causes the lamps to be connected to the power supply. The other method of operation is to energize the pilot wire and relays when the lights should be turned on.

The former of the two methods offers the advantage that should there be a failure in the master control, the pilot-wire circuit, or any relay, the lights will come on. The fact that the lights are on day and night will indicate a control failure, but, will provide light when it is needed. The latter method does not operate any of the lamps when a failure occurs, and no lighting is provided until the necessary maintenance is performed.

The pilot-wire system of control is applicable to both series and multiple circuits, but is used more on the multiple systems.

VI. SELECTION OF SYSTEM

19. General Discussion of Series and Multiple Systems

There are many factors that should be considered in the planning of any street-lighting installation. The desired level of illumination can be achieved through the use of many combinations of lamps, luminaires, luminaire spacings, light distribution patterns, and circuit arrangements. The final decision as to the installation is usually based on initial costs and annual operating costs, with the exception of cases where appearance of the installation is of particular importance.

In many cases, existing equipment and circuits will greatly influence what combination of equipment and circuits will be used. This is particularly true of the circuits. However, if a completely new installation is to be made, including a new circuit to be used only for street-lighting purposes, then the advantages and disadvantages of a number of possible combinations of systems and equipment should be considered.

If a series circuit is to be used, the equipment necessary consists of a constant-current transformer, a primary remote-control oil switch, control equipment, film cutouts, and surge and short-circuit protection. Other equipment that might be used are capacitors for power-factor correction, a protective relay to cause the oil switch to operate to de-energize the circuit in the event of an open-circuit condition, and series-mercury transformers.

In some cases, where safety and local codes require it, insulating transformers are used to insulate the luminaire from the high voltage of the series circuit. When insulating transformers are used, the primary of the transformer is inserted in the series loop and the lamps are operated from the secondary of the transformer. The voltage at the luminaire is limited by the air gap in the insulating transformer.

Until recently, mercury lamps could not be operated from a series circuit without using a series-mercury transformer. The series-mercury transformer trans-

forms the current from the normal 6.6 or 20 amperes supplied by the constant-current transformer to the 3.3 amperes required by the lamp. It is essentially a current transformer, but does have a slight air gap to limit the peak open-circuit voltage developed to a value sufficiently low enough to prevent internal arc-over in the lamp. In order to operate mercury lamps without using series-mercury transformers, a 3.3-ampere series circuit was developed to operate type E-H1 mercury lamps. As another approach to the elimination of the series transformer, a 6.6-ampere mercury lamp was developed.

When mercury lamps are operated on a series circuit without the use of series-mercury transformers, the equipment previously mentioned is necessary, plus a film cutout for each lamp, a potential transformer, and a time-delay relay. This additional equipment is required so that in case of a power dip or outage, which extinguishes the lamps, the circuit will be de-energized for a sufficient length of time to permit the lamps to cool and then restrike in the normal manner. If this is not done, the arc in the lamps will not restrike and the film cutouts will break down, the same as if the lamps had failed.

The 3.3-ampere system requires a special constant-current transformer, but uses standard type E-H1 mercury lamps. The 6.6-ampere system uses a conventional constant-current transformer, but requires the type A-H24 mercury lamp which has a 6.6-ampere rating.

If multiple street lighting is to be used, existing secondary circuits can be used without the need of a separate street-lighting circuit. The lamps served from the existing secondaries can be controlled individually by photoelectric cells, or by a pilot-wire relay scheme.

If a separate circuit is to be used for the multiple system, then the equipment necessary for such a circuit is a standard pole-type distribution transformer, a remote-controlled primary oil switch, or a multiple relay, and some device to provide switching intelligence to the primary switch or multiple relay.

Mercury and fluorescent lamps operated from a multiple circuit require a ballast in order to provide proper voltage to start the lamp, and then to limit the current to a proper value once conduction has started.

Advantages and Disadvantages of Each System—The advantages of each type of system are both tangible and intangible. Local conditions will determine how much weight is given to each of the advantages and disadvantages.

The series circuit permits better control of light due to the smaller light source in a series incandescent lamp. The lamps are more efficient and maintain close to initial lumen output over a relatively long period of the life of the lamp. As a rule, the lamps are more rugged than the incandescent lamps used on multiple circuits.

Series-circuit control equipment is less complicated than corresponding multiple control equipment, and series circuits are more adaptable to simple methods of control.

Outages on the distribution circuits serving the area will not affect the separate series street-lighting circuits.

In rural areas, along arterials and highways, where long circuit runs may be required, the series circuit permits the use of more economical conductor sizes.

The multiple system offers the advantage of having a relatively low voltage at the luminaire. This permits the use of lower cost lamps, and makes it safer to replace lamps or to perform maintenance work on the luminaire. The constant-potential multiple system eliminates the need for special equipment such as the constant-current transformer, the type PC relay, and film cutouts.

Since the multiple system does not operate at primary voltages, the conductors need not be installed on cross-arms. This somewhat simplifies the operating and maintenance problems. Since multiple system conductors need not be on the same crossarm with primary circuits, the problem of the street-lighting circuit conductors swinging into primary circuit conductors is eliminated. However, a broken primary conductor could fall into the multiple circuits which are installed below them. With the present trend to distribution voltages in the 15-kv class, if the street-lighting conductors are installed on the same crossarm with the primary circuit, the crossarm must be made longer. Consequently, the tree trimming problem may become more severe in some areas. Multiple circuits avoid complicating these problems.

The multiple system does not require power-factor correction in most cases, as contrasted to the series system with its relatively low power factor.

The main disadvantage of the multiple system is that it requires relatively large conductors to serve large loads or long runs. However, the use of a 480-volt multiple system permits the use of smaller conductors for these large loads, or long runs than could be used with the more commonly used 120/240-volt multiple system.

20. Calculation of Constant-Current Transformer Loading

The rating of a constant-current transformer is expressed in kw output at the secondary terminals at rated voltage and frequency, and with rated secondary current and power factor. In accordance with ASA standards, constant-current transformers are designed to deliver rated kw output at 95 percent of rated primary voltage, with a load power factor of 99.5 percent.

To determine the required rating of a constant-current transformer for a given installation it is necessary to know: the type and number of lamps to be served; the characteristics of any insulating transformers or series-mercury transformers; conductor size, length, and spacing; ampere rating of protective relay; and the lowest ambient temperature expected.

Incandescent Lamp Load—Straight series operation of incandescent lamps approaches the condition of a 99.5 percent power factor load. The total load kw seen by the constant-current transformer is the lamp load plus the kw losses in the circuit. This total kw must not exceed the kw rating of the constant-current transformer as shown by the loading curves of Figs. 26 and 27. These curves are based on 95 percent

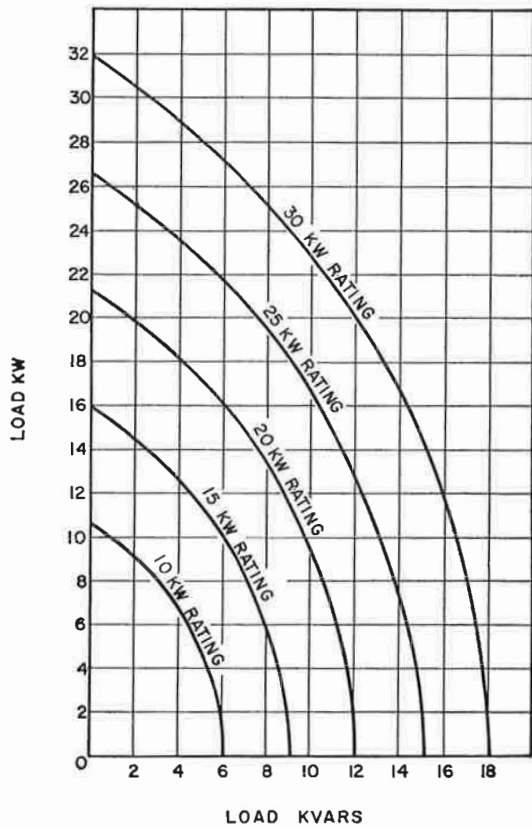

Fig. 26—Relationship of kilowatt and kilovar loading of types CPH, CSPH, and CMH constant-current transformers with 95 per cent of rated primary voltage applied.

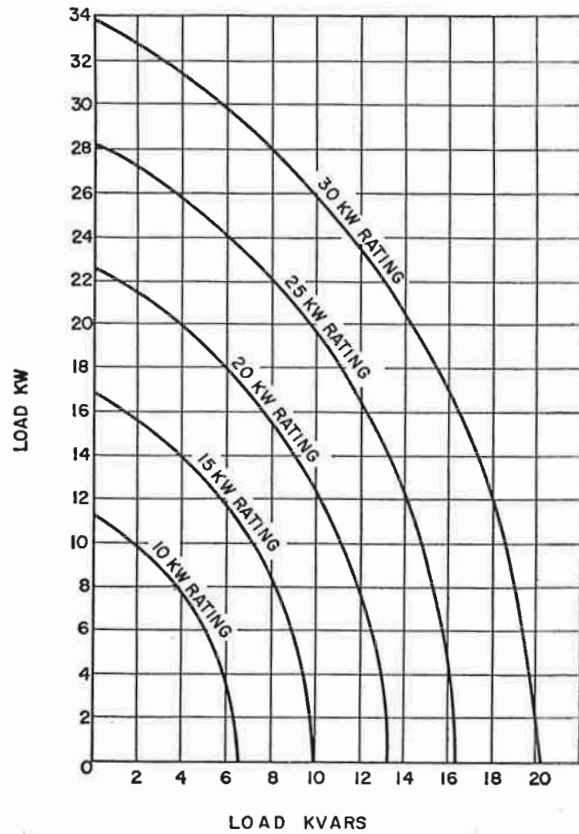

Fig. 27—Relationship of kilowatt and kilovar loading of types CPH, CSPH, and CMH constant-current transformers with 100 per cent of rated primary voltage applied.

and 100 percent of rated primary voltage, respectively. Table 13 shows the kw required by incandescent lamps.

Table 14 gives the kw losses in the circuit conductors. The kvar losses in the circuit are given in Table 15.

Table 13—Data for Incandescent Lamps

Lamp Rating	2000-Hour Lamps				3000-Hour Lamps				
	Straight Series		Insulating Current Transformers		Straight Series		Insulating Current Transformers		
	kw	kvar	kw*	kvar	kw	kvar	kw*	kvar	
1000	6.6	0.065	0	0.077	**	0.0695	0	0.082	**
2500	6.6	0.150	0	0.167	**	0.160	0	0.178	**
4000	6.6	0.220	0	—	—	0.231	0	—	—
4000	15	—	—	0.236	**	—	—	0.248	**
4000	20	0.221	0	—	—	0.231	0	—	—
6000	6.6	0.325	0	—	—	0.343	0	—	—
6000	20	0.310	0	0.345	**	0.326	0	0.360	**
10000	6.6	0.570	0	—	—	0.620	0	—	—
10000	20	0.510	0	0.550	**	0.530	0	0.570	**
15000	20	0.750	0	0.798	**	—	—	—	—
25000	20	1.275	0	1.34	**	—	—	—	—

*Add the Kw loss in the cable from the insulating current transformer to the lamp to the Kw loss in the insulating current transformer to obtain the total Kw loss for the lamp and transformer.

**For insulating current transformer Kvar, use 19 per cent of the total Kw as explained above. To this value add the Kvar of the cable from the transformer to the lamp to obtain the total Kvar for the lamp and transformer.

Table 14—Kilowatt Losses per 1000 Feet of Non-Magnetic Sheathed Copper Cable Buried Directly in Earth

Conductor Size A.W.G.	Ampere Rating of Series Circuit			
	6.6	7.5	15	20
4	0.012	0.016	0.063	0.110
6	0.019	0.025	0.100	0.177
8	0.031	0.040	0.158	0.281
10	0.051	0.066	0.263	0.470

Table 15—Approximate Kilovar Losses per 1000 Feet of #4, #6, and #8 Non-Magnetic Sheathed Copper Cable Buried Directly in Earth

Spacing between Conductors	Ampere Rating of Series Circuit			
	6.6	7.5	15	20
80 Feet	0.01	0.013	0.05	0.09
3 Feet*	0.006	0.008	0.03	0.06

*Use these values for conductors in pole and mast arm.

The use of insulating current transformers on a series circuit results in a load power factor which may be considerably less than 99.5 percent. In determining the required constant-current transformer capacity when insulating current transformers are used, it is necessary to consider the kvars as well as the kw of the load circuits. Table 13 also gives the kvars to be included in the determination of constant-current transformer rating required. The values given in this table assume the normal condition of the lamp in service. Allowances for lamp depreciation and transformer losses are included.

The values in Table 13 are based on the assumption that film cutouts are used on the secondary of the insulating current transformers. If no film cutout were used, and the lamp failed, the secondary of the insulating current transformer would be open circuited. Under the open-circuited condition, the kw losses in the insulating current transformer are negligible but the kvar losses may be in the order of five times the normal maximum kw rating of the transformer. When film-cutout protection is provided, a lamp failure produces a kw load on the series circuit equal to the internal losses of the insulating current transformer. Therefore, only the kw and kvar values for normal operation need be considered for constant-current transformer loading.

In some cases, series-to-multiple transformers will be used and their effect on the series-circuit load should be determined. Where the single-lamp type is used, the following kw and kvar values should be used:

Lamp Watts	kw	kvar
500	0.560	0.080
1000	1.098	0.160

Using these values, the method for calculating loading is identical to that for insulating current transformers. Film cutout protection is recommended.

Series-to-multiple transformers designed to serve two or more multiple lamps have an internal air gap to limit the secondary voltage. A film cutout is not recommended for use with this type of transformer since it would have no purpose in the circuit. The kw and kvar values for series-to-multiple transformer designed to serve two or more multiple lamps are as follows:

Lamp Watts	kw	kvar
0-350	0.380	0.64
350-750	0.790	1.30

It is recommended that not more than one of the series-to-multiple transformers, for lamps up to 350 watts, be used for each 2.5 kw of constant-current transformer capacity. At least 5 kw of constant-current transformer capacity should be available for each of the transformers designed for 350 to 700-watt lamps. The reason for these limitations is the reactance reflected into the series circuit by the internal air gap in the series-to-multiple transformer.

Electric-Discharge Lamp Load—In determining the load placed on a constant-current transformer by mercury and fluorescent lamps, three considerations are necessary:

1. The constant-current transformer capacity required for normal operation of the lamps.
2. The constant-current transformer capacity required to start the lamps at the lowest ambient temperature anticipated.
3. The constant-current transformer capacity required to prevent operation of the protective relay during the starting and warm-up period of the lamps.

It is possible for all three requirements to be different. The conditions of application will determine which requirement is the greatest, and thus will determine the constant-current transformer capacity necessary.

Electric-discharge lamps have negative temperature-resistance characteristics. It is therefore necessary to limit the flow of current through the lamps. The constant-current transformer controls the circuit current to a fixed value. An additional transformer is used with each electric-discharge lamp to match the lamp characteristics to the series circuit by providing the proper starting voltage for the lamps and by transforming the constant current in the series circuit to the proper operating current required by the lamp. Since this matching transformer limits the starting voltage at the lamp, the use of a film cutout can serve no purpose.

Under normal operating conditions, the load on the constant-current transformer is made up of the kw and kvars required by the various lamps and series transformers and the losses in the circuit conductors. Table 16 gives load values for both electric-discharge lamps and series transformers. The circuit losses may be obtained from Tables 14 and 15. When the total kw and kvars have been determined, the values should be

Table 16—Constant-Current Transformer Capacity Required for Operation of Mercury and Fluorescent Lamps

	A-H22 175W. Merc.	C-H5 250W. Merc.	E-H1, 400W, Merc.		A-H18 700W. Merc.	A-H15 1000W. Merc.	Two	Two	Two
			Std. Trans.	U.A.T. Trans.			F72T12/ HO 1.0 amp. Fluor.	F72T12/ SHO 1.5 amp. Fluor.	F48T12/ SHO 1.5 amp. Fluor.
Normal Operation Kw	0.190	0.280	0.428	0.435	0.737	1.050	0.220	0.340	0.231
Kvar	0.127	0.185	0.278	0.194	0.483	0.700	0.165	0.274	0.175
Open-Circuit Kw	0.018	0.040	0.028	0.044	0.075	0.100	0.050	0.050	0.050
Secondary Kvar	0.550	0.700	1.190	1.135	1.940	2.770	0.850	0.850	0.850

Note: 1. These values do not contain any allowance for line losses and are based on nominal lamp and transformer values.
 2. The two sets of values for the E-H1, 400-watt, mercury lamp are for the former ("standard") series-mercury transformer and the new universal aluminum

tank series-mercury transformer.
 3. If the circuit is to serve as a parent circuit to cascade control the operation of a second circuit, 0.53 Kvar must be allowed for the Type AN-2-6.6 (or equal) series-operated oil switch.

plotted on either Fig. 26 or Fig. 27 to find the constant-current transformer capacity required for normal operation.

It should be noted that an open-circuit condition exists on the secondary of a series transformer when the lamp fails. This places a high reactive load on the series circuit and can seriously affect the number of lamps that can be operated on the circuit. This stresses the need for a good maintenance program.

At the moment a series circuit is energized, all of the series transformers on the circuit have an open-circuited secondary. A high impedance is reflected into the series circuit. If adequate constant-current transformer capacity is not provided, the voltage across the lamps may not be sufficient for proper starting. The voltage required by a mercury or fluorescent lamp for proper starting is a function of the lamp design and the ambient temperature. The available starting voltage per lamp is a function of the series transformer design and the primary voltage applied to the constant-current transformer. These factors have been taken into account in Table 17.

During the starting cycle of mercury and fluorescent lamps, the high impedance caused by the open-circuit condition of the series transformers can cause a lower than normal current to flow in the series circuit. If the current is too low, the protective relay will operate and de-energize the circuit. Should this occur, it will be impossible to obtain full normal operation of the lamps. This is most important for a "hot restart" of mercury lamps.

Table 18 gives the recommended maximum number of series-mercury transformers for given constant-current transformer ratings to assure proper "hold-in" operation of the protective relay. There are so many factors involved (including setting, tolerances, and condition of the protective relay) that it is almost impossible to give the absolute maximum number of lamps that can be started without causing the protective relay contacts to "drop-out." Experience indicates the recommended maximums given in the Table are practical values.

Mixed Load—It is possible to use incandescent, mercury, and fluorescent lamps in any combination on a series street-lighting circuit as long as the constant-current transformer capacity is not exceeded. Since the filaments of the incandescent lamps have very little resistance when cold, virtually all of the constant-current transformer capacity is available to start mercury or fluorescent lamps. Under proper conditions, it is possible to install incandescent lamps on a circuit that is loaded to capacity with electric-discharge lamps.

The method for calculating constant-current transformer capacity for mixed incandescent and electric-discharge lamp loads is as follows:

1. The total kw and kvars on the circuit should be determined and plotted on the curve of either Fig. 26 or Fig. 27.
2. The number of mercury or fluorescent lamps on the circuit must not exceed the number of lamps that can be started as given in Table 17.
3. The number of mercury or fluorescent lamps must be checked against Table 18 to make sure that the protective relay will not prevent starting.

The following procedure can be used to determine the constant-current transformer capacity required in a circuit, regardless of the type or types of lamps to be served.

1. Calculate the total circuit kw requirements with all lamps operating. (Tables 13, 14, 16 and 17)
2. Calculate the total circuit kvar requirements with all lamps operating. (Tables 13, 15 and 16)
3. Determine the maximum number of lamps that can be expected to be inoperative at any given time. This will depend upon the maintenance of the system. If only incandescent lamps are used, omit steps 4 and 5.
4. Subtract the normal operating kw and kvar for the number of inoperative lamps (as determined

Table 17—Constant-Current Transformer Capacity in KW Required for Reliable Starting of Mercury and Fluorescent Lamps

Ambient Temp. in Degrees Fahrenheit	Percent of Rated Primary Voltage	A-H22 175W. Merc.	C-H5 250W. Merc.	E-H1, 400 W., Merc.				A-H18 700W. Merc.	A-H15 1000W. Merc.	Two F72T12/ HO 1.0 amp. Fluor.	Two F72T12/ SHO 1.5 amp. Fluor.	Two F48T12/ SHO 1.5 amp. Fluor.
				Std. Trans.		U.A.T. trans.						
				Std. lamp	Lifeguard	Std. lamp	Lifeguard					
-20	100	0.415	0.465	0.760	.710	0.620	0.535	1.15	1.55	0.545	0.715	0.620
	95	0.435	0.490	0.800	.750	0.650	0.560	1.20	1.60	0.575	0.835	0.650
0	100	0.320	0.420	0.620	.580	0.530	0.495	1.15	1.55	0.450	0.630	0.550
	95	0.335	0.440	0.650	.610	0.560	0.510	1.20	1.60	0.470	0.770	0.580
+20 or above	100	0.320	0.420	0.580	.580	0.485	0.485	1.15	1.55			
	95	0.335	0.440	0.610	.610	0.510	0.510	1.20	1.60			
+50 or above	100									0.425	0.525	0.420
	95									0.445	0.650	0.440

NOTE: 1. All values based on nominal lamp and series-mercury or fluorescent transformers.
 2. These values do not consider the use of a protective relay in the circuit which may operate to de-energize the circuit due to low current at the instant of starting.

3. Four values are shown for the E-H1, 400 watt, mercury lamp: the former (standard) transformer, the new (universal aluminum tank) transformer, the standard mercury lamp, and the new "Lifeguard" mercury lamp.

Table 18—Recommended Maximum Number of Series-Mercury Transformers per Constant-Current Transformer for Proper Operation of the Protective Relay

Constant-Current Transformer		A-H22 175W. Merc.	C-H5 250W. Merc.	E-H1, 400W., Merc.		A-H18 700W. Merc.	A-H15 1000W. Merc.	Two 6' HO 1.0 amp. Fluor.	Two 6' SHO 1.5 amp. Fluor.	Two 4' SHO 1.5 amp. Fluor.
Rating in Kw	Percent of Rated Primary Voltage			Std. trans.	U.A.T. trans.					
WITH STANDARD PC-120-3.8/6.6 (OR EQUAL) PROTECTIVE RELAY										
10	100	26	19	11	14	8	5	18	16	16
	95	24	18	10	14	7	5	17	15	15
15	100	40	28	17	22	12	8	27	25	25
	95	38	27	16	21	11	8	25	23	23
20	100	53	38	23	29	16	10	36	33	33
	95	50	36	22	28	15	10	34	31	31
25	100	66	47	29	37	19	13	45	41	41
	95	62	45	27	35	20	13	42	39	39
30	100	80	57	35	44	24	16	55	50	50
	95	76	54	33	42	23	16	52	47	47
WITH NEW PC-120-2.5/6.6 (OR EQUAL) PROTECTIVE RELAY *										
10	100	33	25	15	18	10	7	28	26	26
	95	35	24	14	17	10	7	27	24	24
15	100	50	38	22	26	15	10	42	38	38
	95	52	36	21	25	14	10	40	36	36
20	100	67	52	29	36	20	14	56	51	51
	95	70	49	28	34	19	13	53	49	49
25	100	83	64	37	44	25	17	70	64	64
	95	87	61	35	42	24	17	67	61	61
30	100	105	77	44	53	30	21	84	77	77
	95	100	73	42	51	29	20	80	73	73

NOTE: 1. All values based on nominal lamp and series-mercury or fluorescent transformers.
 2. The two sets of values for the E-H1, 400 watt, mercury lamp are

for the former ("standard") series-mercury transformer or the new ("U.A.T.") series-mercury transformer.
 * This protective relay is now standard production.

- in step 3) from the total circuit kw and kvar. (Table 16)
5. To the kw and kvar determined in step 4, add the kw and kvar for the number of series-mercury or fluorescent transformers operating with open-circuited secondaries (as determined in step 3). (Table 16)
6. Determine whether the voltage at the primary of the constant-current transformer will be 95 per cent or 100 per cent of rated voltage.
7. Using the appropriate curves of either Fig. 26 or Fig. 27, locate the total circuit kw on the ordinate and the total circuit kvar on the abscissa. Plot the point representing the intersection of these two values. The constant-current transformer rating curve immediately above the plotted point is the required rating for operating the circuit once the lamps have started. In the case where only incandescent lamps are used, the indicated constant-current transformer capacity is all that is required. In the case of mercury or fluorescent lamps, additional constant-current transformer capacity may be required.
8. Determine the lowest ambient temperature at which the circuit will be energized. From Table

- 17, determine the constant-current transformer capacity required to start one lamp. The number of lamps multiplied by this value will give the minimum constant-current transformer rating for starting the lamps.
9. If a protective relay is used, check Table 18 to see what constant-current transformer capacity is required to start the lamps without causing the protective relay to drop-out and de-energize the circuit. The larger of the two constant-current transformer ratings determined in steps 8 and 9 is required for starting purposes.
10. Compare the constant-current transformer ratings determined in steps 7, 8 and 9. The largest rating determined is that required for reliable starting and operation.

The following example is given to illustrate the manner in which the required rating of a constant-current transformer is determined. Assume a 6.6-ampere series circuit serving fourteen type E-H1 mercury lamps and fifteen 10,000-lumen, 2000-hour life incandescent lamps. Standard mercury lamps are used with series-mercury transformers and the incandescent lamps are operated from the 20-ampere secondary of 6.6/20-ampere insulating current transformers. A standard 3.8/6.6-ampere protective relay is used. Assume that a maximum of

two mercury lamps are inoperative before circuit maintenance is performed. The 3700-foot primary circuit is underground and consists of direct-buried #6 copper cable. The circuit is run on opposite sides of the street and the separation between conductors is approximately 80 feet. Assume approximately 72 feet of #10 cable are used per lamp from the pole base to the lamp. The lowest ambient temperature to consider is -20 C. The voltage at the primary terminals of the constant-current transformer is 95 per cent of rated voltage at time of lamp turn-on.

From Table 14:

$$\text{kw loss in 72 feet of \#10 cable} = \frac{(72)}{(1000)} (0.470) = 0.034 \text{ kw per lamp}$$

From Table 15:

$$\text{kvar loss in 72 feet of \#10 cable} = \frac{(72)}{(1000)} (0.06) = 0.004 \text{ kvar per lamp}$$

From Table 13:

$$\begin{aligned} \text{kw loss in one insulating current transformer} &= 0.550 \text{ kw} \\ \text{kw loss of one insulating current transformer plus secondary leads} &= 0.550 + 0.034 = 0.584 \text{ kw} \\ \text{kvar loss per insulating current transformer} &= (0.19) (0.584) = 0.111 \text{ kvar} \end{aligned}$$

From Table 14:

$$\text{kw loss in \#6 primary cable} = \frac{(3700)}{(1000)} (0.019) = 0.07 \text{ kw}$$

From Table 15:

$$\text{kvar loss in \#6 primary cable} = \frac{(3700)}{(1000)} (0.01) = 0.04 \text{ kvar}$$

Since two mercury lamps can be expected to be inoperative at any time, open-circuited secondary conditions are assumed for two series-mercury transformers.

From Table 16:

$$\begin{aligned} \text{kw loss in one series-mercury transformer (normal operation)} &= 0.428 \text{ kw} \\ \text{kvar loss in one series-mercury transformer (normal operation)} &= 0.278 \text{ kvar} \\ \text{kw loss in one series-mercury transformer (open circuited secondary)} &= 0.028 \text{ kw} \\ \text{kvar loss in one series-mercury transformer (open-circuited secondary)} &= 1.190 \text{ kvar} \end{aligned}$$

Total kw:

$$\begin{aligned} \text{Insulating current transformers plus secondary leads} &= (15)(0.584) = 8.75 \text{ kw} \\ \text{Series-mercury transformers} &= (12)(0.428) + (2)(0.028) = 5.19 \text{ kw} \\ \text{Primary cable} &= 0.07 \text{ kw} \\ &= \underline{14.01 \text{ kw}} \end{aligned}$$

Total kvar:

$$\begin{aligned} \text{Insulating current transformer} &= (15)(0.111) = 1.67 \text{ kvar} \\ \text{Secondary leads} &= (15)(0.004) = 0.06 \text{ kvar} \\ \text{Series-mercury transformers} &= (12)(0.278) + (2)(1.190) = 5.72 \text{ kvar} \\ \text{Primary cable} &= 0.04 \text{ kvar} \\ &= \underline{7.49 \text{ kvar}} \end{aligned}$$

Plotting the Total kw and Total kvar values on the coordinates of Fig. 26 gives a point that falls just below the curve for a 20-kw constant-current transformer. This, then, is the rating necessary to satisfy operating conditions.

Table 17 shows that 0.80 kw of rated constant-current transformer capacity must be provided to start each E-H1 mercury lamp under the stated conditions. Thus, (14) (0.80) = 11.2 kw of constant-current transformer capacity is required to start the mercury lamps.

Table 18 should be checked to make sure the protective relay will not operate to de-energize the circuit when attempting to start the mercury lamps. The information in this table indicates that a 15-kw constant-current transformer is required.

The highest requirement for constant-current transformer capacity is determined by operating conditions in this case. Therefore, a 20-kw constant-current transformer should be used.

In some cases, a given constant-current transformer is available and it is desired to find how many lamps can be served from that transformer. The following example illustrates this type of a calculation.

Assume a 6.6-ampere series circuit to be served from a 30-kw constant-current transformer. There is to be 100 feet of #6 cable per lamp in the underground primary circuit. The circuit is run on opposite sides of the street and the separation between conductors is approximately 80 feet. The lowest anticipated ambient temperature at time of lamp turn-on is 20 F. The voltage at the primary terminals of the constant-current transformer is 100 per cent of rated voltage at time of lamp turn-on. A standard 3.8/6.6-ampere protective relay is used.

The problem is to determine the maximum number of E-H1 mercury lamps that can be operated on the circuit using standard lamps and series-mercury transformers. Assume no lamp outages.

From Table 14:

$$\text{kw loss in 100 feet of \#6 primary cable} = \frac{(100)}{(1000)} (0.019) = 0.0019 \text{ kw}$$

From Table 15:

$$\text{kvar loss in 100 feet of \#6 primary cable} = \frac{(100)}{(1000)} (0.01) = 0.001 \text{ kvar}$$

From Table 16:

kw loss in one series-mercury transformer =
0.428 kw
kvar loss in one series-mercury transformer =
0.278 kvar

Total kw per lamp:

Primary Cable = 0.0019 kw
Series-mercury transformer = $\frac{0.428 \text{ kw}}{0.43}$ kw

Total kvar per lamp:

Primary cable = 0.001 kvar
Series-mercury transformer = $\frac{0.278 \text{ kvar}}{0.28}$ kvar

For ease of plotting these values on the curves of Fig. 27, multiply both the kw and kvars by ten. Using 4.3 kw as the ordinate and 2.8 kvar as the abscissa, plot the one point. Next, draw a straight line through this point and the origin and extend the line so that it intersects the load curve for a 30-kw constant-current transformer. This intersection shows that 21.1 kw is available to operate the mercury lamps. At 0.43 kw per lamp, the number of mercury lamps that can be operated is:

$$\frac{(21.1)}{(0.43)} = 49 \text{ lamps}$$

Table 17 shows that 0.58 kw of constant-current transformer capacity is required to start each mercury lamp. Therefore the number of lamps that can be started is:

$$\frac{(30)}{(0.58)} = 51 \text{ lamps.}$$

Table 18 indicates that no more than 35 E-H1 lamps can be started on the circuit without causing the protective relay to drop-out and de-energize the circuit. Thus, the protective relay is the limiting factor in this application. A maximum of 35 lamps is the limit for this circuit under the specified conditions.

More lamps could be installed on the circuit if the new universal aluminum tank series-mercury transformer were used to operate LIFEGUARD E-H1 mercury lamps. Assuming all other conditions to be the same, an analysis similar to that above shows a maximum of 56 lamps can be operated, 62 can be started, and 44 can be started without causing the protective relay to de-energize the circuit. The protective relay is still the limiting factor, but 44 lamps can be installed instead of 35 as in the previous case.

If the protective relay were changed from the 3.8/6.6-ampere relay to the 2.5/6.6-ampere relay, the maximum number of lamps that could be started without causing the relay to drop-out would be 53.

The procedure outlined above for determining constant-current transformer loading is realistic. Using this procedure will result in the most efficient use of constant-current transformer capacity while assuring dependable operation of the lamps for all reasonable anticipated conditions.

There are a number of existing installations in which the number of mercury lamps exceeds the recommendations determined from this procedure. This has been done as an economy measure in most cases to minimize the number of constant-current transformers and associated equipments on the system. Although some savings can be realized by loading a transformer beyond the recommended value, these savings may be made at the expense of more lamp outages, and possible poor lumen maintenance and lower light output.

21. Maintenance

Dirt on lamps, reflectors, and enclosing glassware is the largest contributor to lighting depreciation. In some checks of street lighting installations, depreciation factors as high as 60 per cent have been found. The lighting becomes completely inadequate if allowed to depreciate to such an extent. Luminaires should be cleaned regularly according to a definite prearranged schedule.

The cleaning schedule should be set up on an annual basis in such a way that under normal operating conditions the lighting depreciation due to the accumulation of dirt will not exceed 15 per cent. Cleaning every two or three months will accomplish this result under average dirt conditions, but in very dirty locations, cleaning may be necessary every few weeks.

Lamp replacements should always be made as promptly as possible, since adequate lighting at a given location is largely dependent on the light output of a single luminaire. If one lamp is out, a serious traffic hazard may exist. Lamps may be replaced individually, as they burn out, or on a group replacement plan.

Individual Lamp Replacement—A plan is particularly desirable where lamp breakage is high or where lamps are near maintenance headquarters. Patrol crews handle outages and answer outage complaints.

Group Lamp Replacement—Group replacement, the periodic replacement of all lamps on the system, is preferred by some street lighting maintenance organizations for several reasons:

1. There is always a time lag between a lamp failure and its replacement; so a reduction in the total number of outages, by periodic replacement, results in fewer hours of darkness and danger caused by the dead lamps.
2. Group replacement automatically eliminates the dim lamps on series circuits.
3. Fewer replacements are required while the circuits are energized and during hours of darkness. Both factors contribute to the safety of the crews.
4. Complaints of outages are minimized. The basis for this group replacement lies in the uniformity of lamp life achieved through close control of manufacture. Premature outages can be held to approximately 10 per cent if group replacement is made before the lamp has burned a sufficient time to be approaching the accelerated point on the mortality curve. Of course, the few lamp outages which do occur should be replaced promptly.

Regulation of Voltage or Current—The nominal life of an incandescent lamp has been chosen with the intent of maintaining a reasonable balance between operating efficiency and cost of lamp replacement for the average installation.

Voltage changes are quite common on multiple circuits, and it is recommended that the voltage throughout the system be checked at least once a year to obtain a true picture of operating conditions.

The constant-current transformer maintains close control over the secondary current; as a result, series circuits are relatively free from trouble due to variations in current. Constant-current transformers require very little maintenance. However, at least once a year the following checks should be made:

1. Secondary current value. Weight or position of counterweight should be adjusted to correct any deviation from correct value.
2. Sensitivity should be checked by checking movement of mechanism. Poor sensitivity can be caused by misalignment of parts or foreign materials in the bearings.
3. Oil should be tested for moisture or contamination by a dielectric test.

The oil switches should be given standard switch tests and inspections.

Relays and Switches—The air-insulated relays used in street-lighting service are of rugged construction to assure long life without frequent inspection. However, inspection once each year will often disclose conditions which can be easily corrected to assure longer life without rebuilding. Factory adjustments of the mechanism should not be changed unless faulty operation clearly indicates that adjustments are necessary.

Time switches should be given the same care as any other high-grade time-keeping mechanism.

Corrective Measures—The difference in the maintenance on series and multiple circuits, other than the checks given above, can best be given by a brief review of some of the troubles and causes of these troubles on each type of system.

On a multiple system, the following troubles and causes may be expected when incandescent lamps are used:

Indication of Trouble	Probable Cause or Causes
1. Lamp out, but apparently O.K.	Lamp loose in socket Loose or broken connections Failure of individual control
2. Lamp burns dimly	Low voltage
3. Short lamp life	High voltage Incorrect lamp Mechanical damage Excessive vibration
4. Lamp breakage	Water contacting lamp bulb Lamp touches luminaire

Indication of Trouble	Probable Cause or Causes
5. All lamps out	Transformer primary fuse open CSP transformer secondary breaker open Failure in multiple relay Failure in primary switch Failure of control

On series circuits, the following might be expected:

Indication of Trouble	Probable Cause or Causes
1. Lamp out, but apparently O.K.	Lamp loose in socket Loose or broken connections Film cutout punctured
2. One lamp burns dimly	Partial failure of film cutout Incorrect lamp Filament broken and rewelded
3. All lamps burn dimly	Low current—constant current transformer jammed. Low current—constant current transformer out of adjustment Low current—low primary voltage Low current—constant current transformer overloaded.
4. Portion of circuit out	Film cutouts punctured—incorrect cutouts Film cutouts punctured—lightning Film cutouts punctured—power surges Circuit grounded at two or more points
5. All lamps out	Feeder power off Control power off Series circuit open Primary switch failure
6. Short lamp life	High current—constant current transformer jammed High current—constant current transformer out of adjustment Mechanical damage Incorrect lamp Excessive vibration
7. Lamp breakage	Water contacting lamp bulb Lamp touches luminaire
8. Burned sockets and receptacles	Improper film cutout

continued on next page

Indication of Trouble	Probable Cause or Causes
9. Radio and telephone interference	Overhead circuit contacts trees Inadequate insulation on high voltage circuits Open-circuited isolating transformers

22. Cost Comparisons

In order to provide a true picture of the relative costs of different systems, a cost analysis should include not only labor and material costs for the original installation, but also all maintenance, operation, and amortizing costs. Taxes, interest, and insurance should be included when amortizing the cost of the installation.

As labor costs and local practices vary throughout the country, it is impossible to make a cost comparison that is exact for all cases. However, for purpose of illustration, a cost study is presented which uses an average of costs for various parts of the country. While the study is not exact for any one locality or installation, it will provide an indication as to the relative costs of the various systems compared. In the cost studies, the actual mounting height is used rather than the "nominal" mounting height of 25 feet or 30 feet. As there is a difference in luminaire mounting height for transformer-base or anchor-base poles, this then results in a different coefficient of utilization for any particular unit when using different types of standards.

Table 19 presents a cost comparison of various types of luminaires and distribution systems that may be employed to provide illumination levels used in downtown business districts today. The systems utilizing color-corrected mercury lamps are included to show the relative cost between the 400-watt clear, and 400-watt color-corrected mercury lamps, and also to provide an indication of relative cost of higher wattage lamps. As the 400-watt clear mercury lamp is a more familiar lamp than the color-corrected or higher wattage lamps, this lamp was chosen as the mercury lamp to be used in all of the cost studies, even though the trend is toward the use of color-corrected lamps for new installations. The 425-watt A-H17 high-voltage lamp using a reactor ballast becomes unstable at approximately 90 per cent of rated lamp open-circuit voltage. Consequently, this lamp was not used as the 100 per cent base, as this characteristic would eliminate it from consideration for many installations. The least expensive system (excluding the high-voltage mercury lamp) is the E-H1 mercury lamp with the high-reactance ballast when served from a 480-volt distribution system. This system was used as the 100 per cent base.

Table 20 presents a cost comparison of various luminaires that might be used to provide illumination levels used on many high density traffic roadways and secondary business streets.

Table 21 is a cost study of installations for expressway type roads. This study also shows a comparison between the cost of mounting the luminaires along the sides of the road or mounting them in the medial strip.

The form used for the cost studies is the one officially recognized by the Illuminating Engineering Society. Most items are self-explanatory, but Line 14, "Net luminaire cost (each)," Line 15, "Net additional accessory costs per luminaire," and Line 16, "Estimated wiring and installation cost per luminaire," should be explained.

Line 14 includes the cost of the luminaire, standard, and ballast or series transformer. Using System I of Table 19 as an example, the cost is as follows:

Luminaire	= \$ 73.76
Standard	= 135.74
6.6-20 amp. series transformer	= 65.45
Total	= \$274.95

Line 15 includes the cost of the wire, transformer, and control equipment. Although the cost study is for a one-mile section of roadway, this figure was obtained on the basis of the total installation being much longer. A 30-kw constant-current transformer was loaded as indicated in the cost study, and the cost for this complete circuit was pro-rated among the number of units on the circuit to obtain the cost per luminaire. Again using system I of Table 19, the cost is obtained as follows:

30-Kw "package type," self-protecting constant-current transformer	= \$1782.55
Hanger iron	= 12.65
Photo-control	= 39.00
2700 ft #8 1/c 6000-volt direct-buried cable	= 569.70
2400 ft #10 R WRH wire	= 94.56
Total cost for the one circuit	\$2498.46

$$\text{Cost per luminaire} = \frac{\$2498.46}{34} = \$73$$

Line 16 includes the labor costs for installing and connecting all equipment. Again, this cost per luminaire was figured on the total cost of one circuit, and then this cost was pro-rated among the number of luminaires on the circuit to obtain the cost per luminaire. Continuing using System I of Table 19, the cost is obtained as follows:

Install transformer base standard complete—\$50.00 (each)	= \$1700.00
Install and connect luminaire—\$7.00 (each)	= 238.00
Install and connect 6.6-20 ampere series transformer \$6.00 (each)	= 204.00
Install and connect package type self protecting constant-current transformer	= 110.00
Install and connect photo control	= 7.00
Install cable in pole and bracket—1/c—\$10.00 (each)	= 340.00
Install 100 ft. underground cable—2 cables \$42.00/100 ft. (each)	= 42.00
Install 2200 ft. underground cable—1 cable \$40.00/100 ft. (each)	= 880.00
Total Cost for the one circuit	= \$3521.00

$$\text{Cost per luminaire} = \frac{\$3521.00}{34} = \$104$$

Table 20—Cost Comparison* of Six Systems

LIGHTING SYSTEM NUMBER	120/240 ¹		480 Volt ¹			240/480 ¹	
	I	II	III High Reactance	IV Reactor	V High Reactance	VI	
DESCRIPTION OF LIGHTING SYSTEMS	1. Type of lamp (Fil., merc., fluor., etc.)	Filament	Filament	Mercury	Mercury	Color Corr. Mercury	Fluorescent
	2. Lamp description (Type)	15,000 L	10,000 L	E-H1	A-H17	J-H1	F72T12/RS
	3. Type of luminaire	PS-52	PS-40	400	425	400	95
	4. Number of lamps per luminaire	800	575	Horizontal Mercury	Horizontal Mercury	Horizontal Mercury	Tilted Fluorescent
BASIC DATA	5. Rated initial lamp lumens per luminaire	Pendant	Pendant	One	One	One	Four
	6. Lamp life	One	One	One	One	One	One
	7. Watts per luminaire (including auxiliary + 10 per cent line loss)	15,000	10,000	21,000	21,000	20,000	23,400
	8. Coefficient of utilization	1,350	1,350	7,000	7,000	7,000	7,500
	9. Maintenance factor	880	632	505	495	505	504
	10. Number of luminaires	.378	.466	.503	.503	.453	.294
	11. Average footcandles initial	—	—	—	—	—	—
	12. Energy rate (\$ per KWH)	112	136	60	60	70	92
	13. Estimated burning hours per year	95 Opp	78 Opp	88 Stag	88 Stag	76 Stag	115 Opp
	14. Net luminaire cost (each) ²	2.0	2.0	2.0	2.0	2.0	2.0
	15. Net additional accessory cost per luminaire ³	\$.01	.01	.01	.01	.01	.01
	16. Estimated wiring and installation cost per luminaire	4,000	4,000	4,000	4,000	4,000	4,000
	INITIAL COST	17. Net initial lamp cost each (list less 30 per cent)	\$ 142.00	116.00	185.00	166.00	198.00
18. Net initial lamp cost per luminaire (4 × 17)		\$ 70.00	58.00	26.00	26.00	25.00	25.00
19. Total initial cost per luminaire (14 + 15 + 16 + 18)		\$ 67.00	64.00	76.00	76.00	75.00	71.00
20. TOTAL INITIAL COST (10 × 19)		\$ 2.70	1.02	14.00	14.18	16.10	2.63
21. Net initial lamp cost per luminaire (4 × 17)		\$ 2.70	1.02	14.00	14.18	16.10	10.52
ANNUAL FIXED CHGS.	22. Total initial cost per luminaire (14 + 15 + 16 + 18)	\$ 282.00	239.00	301.00	282.00	314.00	400.00
	23. ANNUAL FIXED CHARGES (15 per cent of 22)	\$ 42.30	35.85	45.15	42.30	47.10	60.00
	24. Annual no. lamp replacements (4 × 10 × 13 ÷ 6)	\$ 31,584.00	32,504.00	18,060.00	16,920.00	21,980.00	36,800.00
	25. Annual cost of replacement lamps (17 × 24)	\$ 279.00	238.00	278.00	268.00	298.00	389.00
ANNUAL OPERATING COSTS	26. Total initial cost less lamps (10 × 21)	\$ 31,248.00	32,368.00	17,220.00	16,080.00	20,860.00	35,788.00
	27. Annual cost of replacement parts ⁴	\$ 4,687.00	4,855.00	2,583.00	2,412.00	3,129.00	5,368.00
	28. Total annual maintenance material cost (25 + 26)	\$ 896.00	411.00	476.00	482.00	644.00	515.00
	29. Estimated labor cost to replace one lamp	\$ 312.00	324.00	172.00	161.00	209.00	358.00
	30. Total labor costs to replace lamps (24 × 28)	\$ 1,208.00	735.00	648.00	643.00	853.00	873.00
	31. Estimated cleaning cost per luminaire	\$ 1.00	1.00	1.00	1.00	1.00	1.00
	32. Number of cleanings per year	2	2	2	2	2	2
	33. Annual cleaning cost (10 × 30 × 31)	\$ 332.00	403.00	34.00	34.00	40.00	196.00
	34. Total Annual Maintenance Cost (27 + 33)	\$ 1,540.00	1,138.00	782.00	787.00	1,053.00	1,069.00
	35. Annual Energy Cost (7 × 10 × 12 × 13 ÷ 1000)	\$ 1.00	1.00	1.00	1.00	1.00	2.00
	36. TOTAL ANNUAL OPERATING COST (34 + 35)	\$ 2.00	2.00	2.00	2.00	2.00	2.00
TOTAL & REL. COSTS	37. TOTAL ANNUAL COST (23 + 36)	\$ 5,706.00	4,848.00	2,014.00	1,985.00	2,447.00	3,292.00
	38. Relative Annual Cost	\$ 10,393.00	9,703.00	4,597.00	4,397.00	5,576.00	8,060.00
	39. Annual Cost per Footcandle (37 + 11)	226%	211%	100%	96%	121%	188%
	40. Relative Annual Cost per Footcandle	\$ 5,196.00	4,852.00	2,298.00	2,198.00	2,788.00	4,330.00

*Comparison assumes one mile section of roadway, 60 feet curb to curb, overhead circuits, wood poles, approx. 30-foot mounting height, average of 2.0 footcandles provided initially. Distribution system is independent of existing systems. Minimum temperature at turn-on time assumed to be 0 F.
¹Loading based on the use of a completely self-protecting Class A transformer

with taps, loaded up to 125 per cent of rated capacity.
²Luminaire+pole+ballast.
³Wire+transformer+control equipment.
⁴One per cent of total initial cost less lamps (Line 22).

Table 21—Cost Comparison* of Six Systems

LIGHTING SYSTEM NUMBER	Poles Mounted on Outside of Roadway			Poles Mounted in Medial Strip				
	I	II	III	IV	V	VI		
	120/240V ¹	480V ¹	240/480V ¹	120/240V ¹	480V ¹	240/480V ¹		
DESCRIPTION OF LIGHTING SYSTEMS	1. Type of lamp (Fil., merc., fluor., etc.)	Filament	Mercury	Fluorescent	Filament	Mercury	Fluorescent	
	2. Lamp description (Type)	10,000 L	PS-40	E-H1	F72T12/RS	PS-40	E-H1	F72T12/RS
	(Watts per lamp only)	575	400	95	575	400	95	
	3. Type of luminaire	Pendant	Horizontal Mercury	Tilted Fluorescent	Pendant	Horizontal Mercury	Tilted Fluorescent	
4. Number of lamps per luminaire	One	One	Four	One	One	Four		
BASIC DATA	5. Rated initial lamp lumens per luminaire	10,000	21,000	23,400	10,000	21,000	23,400	
	6. Lamp life	1,350	7,000	7,500	1,350	7,000	7,500	
	7. Watts per luminaire (including auxiliary) + 10 per cent line loss	632	505	504	632	505	504	
	8. Coefficient of utilization	.358	.413	.22	.304	.399	.22	
	9. Maintenance factor	—	—	—	—	—	—	
	10. Number of luminaires	176	72	124	208	76	124	
	Spacing	60 Opp	72 Stag	85 Opp	51	139	85	
	11. Average footcandles initial	2.0	2.0	2.0	2.0	2.0	2.0	
	12. Energy rate (\$ per KWH)	.01	.01	.01	.01	.01	.01	
	13. Estimated burning hours per year	4,000	4,000	4,000	4,000	4,000	4,000	
INITIAL COST	14. Net luminaire cost (each) ²	\$ 189.—	268.—	372.—	133.—	203.—	314.—	
	15. Net additional accessory cost per luminaire ³	\$ 34.—	22.—	20.—	29.—	19.—	18.—	
	16. Estimated wiring and installation cost per luminaire	\$ 70.—	81.—	76.—	45.—	53.—	47.—	
	17. Net initial lamp cost each (list less 30 per cent)	\$ 1.02	14.00	2.63	1.02	14.00	2.63	
	18. Net initial lamp cost per luminaire (4 × 17)	\$ 1.02	14.00	10.52	1.02	14.00	10.52	
	19. Total initial cost per luminaire (14 + 15 + 16 + 18)	\$ 294.—	385.—	478.—	208.—	289.—	390.—	
20. TOTAL INITIAL COST (10 × 19)	\$51,744.—	27,720.—	50,272.—	43,264.—	21,064.—	48,360.—		
ANNUAL FIXED CHGS.	21. Initial cost per luminaire less lamps (14 + 15 + 16)	\$ 293.—	371.—	468.—	207.—	275.—	379.—	
	22. Total initial cost less lamps (10 × 21)	\$51,568.—	26,712.—	58,032.—	43,056.—	20,900.—	46,996.—	
	23. ANNUAL FIXED CHARGES (15 per cent of 22)	\$ 7,735.—	4,007.—	8,705.—	6,458.—	3,135.—	7,049.—	
ANNUAL OPERATING COSTS	24. Annual no. lamp replacements (4 × 10 × 13 + 6)	521	41	264	616	43	264	
	25. Annual cost of replacement lamps (17 × 24)	\$ 531.—	574.—	692.—	628.—	602.—	694.—	
	26. Annual cost of replacement parts ⁴	\$ 516.—	267.—	580.—	430.—	209.—	470.—	
	27. Total annual maintenance material cost (25 + 26)	\$ 1,047.—	841.—	1,272.—	1,058.—	811.—	1,164.—	
	28. Estimated labor cost to replace one lamp	\$ 1.—	1.—	1.—	1.—	1.—	1.—	
	29. Total labor costs to replace lamps (24 × 28)	\$ 521.—	41.—	264.—	616.—	43.—	264.—	
	30. Estimated cleaning cost per luminaire	\$ 1.—	1.—	2.—	1.—	1.—	2.—	
	31. Number of cleanings per year	2	2	2	2	2	2	
	32. Annual cleaning cost (10 × 30 × 31)	\$ 352.—	144.—	496.—	416.—	152.—	496.—	
	33. Total annual maintenance labor cost (29 + 32)	\$ 873.—	185.—	760.—	1,032.—	195.—	760.—	
34. Total Annual Maintenance Cost (27 + 33)	\$ 1,910.—	1,026.—	2,032.—	2,090.—	1,006.—	1,924.—		
35. Annual Energy Cost (7 × 10 × 12 × 13 + 1000)	\$ 4,449.—	1,454.—	2,500.—	5,258.—	1,535.—	2,500.—		
36. TOTAL ANNUAL OPERATING COST (34 + 35)	\$ 6,359.—	2,480.—	4,532.—	7,348.—	2,541.—	4,424.—		
TOTAL & REL. COSTS	37. TOTAL ANNUAL COST (23 + 36)	\$14,094.—	6,487.—	13,237.—	13,806.—	5,676.—	11,473.—	
	38. Relative Annual Cost	248%	114%	233%	243%	100%	202%	
	39. Annual Cost per Footcandle (37 ÷ 11)	\$ 7,047.—	3,244.—	6,618.—	6,903.—	2,838.—	5,736.—	
	40. Relative Annual Cost per Footcandle	248%	114%	233%	243%	100%	202%	

*Comparison assumes one mile section of divided roadway, 30-20-30 feet, overhead circuits, steel poles, approx. 30-foot mounting height, average of 2.0 footcandles provided initially. Distribution system is independent of existing systems. Minimum temperature at turn-on time assumed to be 0 F.
¹Loading based on the use of a completely self-protecting Class A transformer

with taps, loaded up to 125 per cent of rated capacity.
²Luminaire+pole+ballast.
³Wire+transformer+control equipment.
⁴One per cent of total initial cost less lamps (Line 22).

It is not practical to include a complete list of all material and labor costs used in these comparisons. However, the above costs are typical of those used throughout the cost studies. It is not expected that the costs shown above agree exactly with the costs for any particular installation, as explained previously. Although these costs may be judged to be high or low in regard to a specific installation, the importance of these cost studies does not lie in the actual costs (although this should not be a large difference when compared to a specific case), but in the relative costs. As long as the same costs are used in all cases, the relative cost will be unaffected.

The cost study comparing incandescent, fluorescent, and mercury luminaires served by series or multiple circuits (Table 19) shows that the type of distribution system will make little if any difference in either the initial or annual operating cost. This can be expected for all cases except where very long runs are to be made, such as along residential or secondary traffic streets. In this case, the series distribution system will tend to be more economical.

The use of wood poles and overhead wiring (Table 20) results in a considerable savings in the cost per luminaire. When the total annual cost is considered, however, the savings are not as great as might be expected. The savings show a range of only 20 per cent to 30 per cent, depending upon the system being considered.

Although some economy can be realized by using twin-bracket poles mounted in a medial strip, the savings are not as great as might at first be expected. (See Table 21.) This is due almost entirely to the fact that more units are required, because the coefficient of utilization is lower. This, then, means more equipment to purchase, install, operate, and maintain. Also, the additional bracket tends to off-set some of the difference. This is especially true in view of the fact that more luminaires are required. Hence, the number of twin-bracket poles for medial strip mounting is more than half the number of single-bracket poles for mounting at the side of the road. While the Total Initial Cost is approximately 20 per cent to 25 per cent less for the medial strip mounting systems, the annual cost is approximately the same for incandescent and only about 15 per cent less for the mercury and fluorescent systems. It is felt by some authorities that mounting poles in the medial strip presents a much more dangerous traffic hazard than mounting them at the sides of the road. In view of this, the small savings made possible by the method may not be justified.

The cost of any particular installation will depend upon many factors, and will vary greatly depending

upon the specific conditions encountered for each installation. For the particular set of conditions for these cost studies, the approximate cost for a system using underground wiring and steel poles is \$400 per unit for incandescent, \$550 per unit for fluorescent, and \$450 per unit for mercury. If wood poles and overhead wiring are used, the cost per unit is approximately \$250 for incandescent, \$400 for fluorescent, and \$300 for mercury. To obtain more accurate costs for any given installation, the cost studies presented here should be followed through in detail, and the exact costs for the conditions involved substituted for the values shown. However, for most cases the figures given above will provide a fair approximation.

Although the incandescent systems have the lowest cost per unit, more units are required, to provide a given illumination level than are required with mercury because of the lower lumen output and utilization. The systems with the fluorescent lamp, which is the most efficient light source today, also require more units than are required with mercury, because of the low coefficient of utilization. When all factors are taken into consideration, a given illumination level can be obtained more economically by using mercury than by using incandescent or fluorescent units. As pointed out previously, the least expensive method of obtaining a given illumination level is not always the most desirable method. Mercury, while being the least expensive method, detracts from the brilliance of colors predominantly in the red end of the spectrum. In many cases, a more expensive installation will be justified from the standpoint of color rendition alone. Depending upon the color rendition desired, the new Silver-White colored mercury or the fluorescent-mercury lamps can be used to obtain better color rendition and still retain the inherent economy of the mercury source. Such factors as this, and many others from an appearance or aesthetic viewpoint, may have such a strong influence as to relegate cost to a position of secondary importance. These factors must be taken into account for each installation and, although they do not show up in a cost study, they may very definitely have a monetary value, even though the exact amount cannot be determined.

REFERENCES

1. Street Lighting—Then and Now, *Illuminating Engineering*, Vol. 51, January, 1956, pp. 86-96.
2. Westinghouse Lighting Handbook, April, 1958 revision. Westinghouse Electric Corporation, Lamp Division, Bloomfield, New Jersey.
3. American Standard Practice for Street and Highway Lighting, A.S.A. Standard D12.1—1953, UDC 628.971.

APPENDIX

THIS APPENDIX includes a number of tables of application data collected from numerous sources. These tables are included as an aid to the user of this book in solving distribution system problems.

Tables 1 through 11 are tables of conductor impedance and physical characteristics. Included are data for overhead, open-wire lines; overhead self-supporting cable; and cables for underground circuits.

Table 12 is included to facilitate derivation of equivalent circuits for power and distribution transformers from the impedance data usually furnished by the manufacturer.

Table 14 on residential underground distribution system design practices is included because of the many different practices by the various companies and because of the increasing application of underground systems in residential areas. This table has been abstracted from the article "Residential Distribution Adaptable" by Mr. F. E. Andrews which appeared in the December 12, 1955 issue of *Electrical World*.

The subject of lightning protection is to be included in Volume II. However, for quick reference on lightning arrester selection Table 15 is included.



Table 1—Characteristics of COPPER Conductors, Hard Drawn, 97.3 Per cent Conductivity

Size of Conductor		Number of Strands	Diameter of Individual Strands Inches	Outside Diameter Inches	Breaking Strength Pounds	Weight Pounds per Mile	Approx. Current Carrying Capacity* Amps	Geo-metric Mean Radius at 60 Cycles Feet	r_a Resistance Ohms per Conductor per Mile								X_a Inductive Reactance Ohms per Conductor At 1 Ft. Spacing			X_a' Shunt Capacitive Reactance Megohms per Conductor Per Mile At 1 Ft. Spacing			
Circular Mils	A. W. G. or B. & S.								25°C. (77°F.)				50°C. (122°F.)				25 cycles	50 cycles	60 cycles	25 cycles	60 cycles	25 cycles	60 cycles
									d-c	25 cycles	50 cycles	60 cycles	d-c	25 cycles	50 cycles	60 cycles							
1 000 000	...	37	0.1644	1.151	43 830	16 300	1 300	0.0368	0.0585	0.0594	0.0620	0.0634	0.0640	0.0648	0.0672	0.0685	0.1666	0.333	0.400	0.216	0.1081	0.0901	
900 000	...	37	0.1560	1.092	39 510	14 670	1 220	0.0349	0.0650	0.0658	0.0682	0.0695	0.0711	0.0718	0.0740	0.0752	0.1693	0.339	0.406	0.220	0.1100	0.0916	
800 000	...	37	0.1470	1.029	35 120	13 040	1 130	0.0329	0.0731	0.0739	0.0760	0.0772	0.0800	0.0806	0.0826	0.0837	0.1722	0.344	0.413	0.224	0.1121	0.0934	
750 000	...	37	0.1424	0.997	33 400	12 230	1 090	0.0319	0.0780	0.0787	0.0807	0.0818	0.0853	0.0859	0.0878	0.0888	0.1739	0.348	0.417	0.226	0.1132	0.0943	
700 000	...	37	0.1375	0.963	31 170	11 410	1 040	0.0308	0.0836	0.0842	0.0861	0.0871	0.0914	0.0920	0.0937	0.0947	0.1759	0.352	0.422	0.229	0.1145	0.0954	
600 000	...	37	0.1273	0.891	27 020	9 781	940	0.0285	0.0975	0.0981	0.0997	0.1006	0.1066	0.1071	0.1086	0.1095	0.1799	0.360	0.432	0.235	0.1173	0.0977	
500 000	...	37	0.1162	0.814	22 510	8 151	840	0.0260	0.1170	0.1175	0.1188	0.1196	0.1280	0.1283	0.1296	0.1303	0.1845	0.369	0.443	0.241	0.1205	0.1004	
500 000	...	19	0.1622	0.811	21 590	8 151	840	0.0256	0.1170	0.1175	0.1188	0.1196	0.1280	0.1283	0.1296	0.1303	0.1853	0.371	0.445	.241	0.1206	0.1005	
450 000	...	19	0.1539	0.770	19 750	7 336	780	0.0243	0.1300	0.1304	0.1316	0.1323	0.1422	0.1426	0.1437	0.1443	0.1870	0.376	0.451	0.245	0.1224	0.1020	
400 000	...	19	0.1451	0.726	17 560	6 521	730	0.0229	0.1462	0.1466	0.1477	0.1484	0.1600	0.1603	0.1613	0.1619	0.1909	0.382	0.458	0.249	0.1245	0.1038	
350 000	...	19	0.1357	0.679	15 590	5 706	670	0.0214	0.1671	0.1675	0.1684	0.1690	0.1828	0.1831	0.1840	0.1845	0.1943	0.389	0.466	0.254	0.1269	0.1058	
350 000	...	12	0.1708	0.710	15 140	5 706	670	0.0225	0.1671	0.1675	0.1684	0.1690	0.1828	0.1831	0.1840	0.1845	0.1918	0.384	0.460	0.251	0.1263	0.1044	
300 000	...	19	0.1257	0.629	13 510	4 891	610	0.01987	0.1950	0.1953	0.1961	0.1966	0.213	0.214	0.214	0.215	0.1982	0.396	0.476	0.259	0.1296	0.1080	
300 000	...	12	0.1581	0.657	13 170	4 891	610	0.0208	0.1950	0.1953	0.1961	0.1966	0.213	0.214	0.214	0.215	0.1957	0.392	0.470	0.256	0.1281	0.1068	
250 000	...	19	0.1147	0.574	11 360	4 076	540	0.01813	0.234	0.234	0.235	0.235	0.256	0.256	0.257	0.257	0.203	0.406	0.487	0.266	0.1329	0.1108	
250 000	...	12	0.1443	0.600	11 130	4 076	540	0.01902	0.234	0.234	0.235	0.235	0.256	0.256	0.257	0.257	0.200	0.401	0.481	0.263	0.1313	0.1094	
211 600	4/0	19	0.1055	0.528	9 617	3 450	480	0.01688	0.276	0.277	0.277	0.278	0.302	0.302	0.303	0.303	0.207	0.414	0.497	0.272	0.1359	0.1132	
211 600	4/0	12	0.1328	0.552	9 483	3 450	490	0.01750	0.276	0.277	0.277	0.278	0.302	0.302	0.303	0.303	0.205	0.409	0.491	0.269	0.1343	0.1119	
211 600	4/0	7	0.1739	0.522	9 154	3 450	480	0.01579	0.276	0.277	0.277	0.278	0.302	0.302	0.303	0.303	0.210	0.420	0.503	0.273	0.1363	0.1136	
167 800	3/0	12	0.1183	0.492	7 556	2 736	420	0.01559	0.349	0.349	0.349	0.350	0.381	0.381	0.382	0.382	0.210	0.421	0.505	0.277	0.1384	0.1163	
167 800	3/0	7	0.1548	0.464	7 366	2 736	420	0.01404	0.349	0.349	0.349	0.350	0.381	0.381	0.382	0.382	0.216	0.431	0.518	0.281	0.1405	0.1171	
133 100	2/0	7	0.1379	0.414	5 926	2 170	360	0.01252	0.440	0.440	0.440	0.440	0.481	0.481	0.481	0.481	0.222	0.443	0.532	0.289	0.1445	0.1205	
105 500	1/0	7	0.1228	0.368	4 752	1 720	310	0.01113	0.555	0.555	0.555	0.555	0.606	0.607	0.607	0.607	0.227	0.455	0.546	0.298	0.1488	0.1240	
83 690	1	7	0.1093	0.328	3 804	1 364	270	0.00992	0.699	0.699	0.699	0.699	0.765	0.765	0.765	0.765	0.233	0.467	0.560	0.306	0.1528	0.1274	
83 690	1	3	0.1670	0.360	3 620	1 351	270	0.01016	0.692	0.692	0.692	0.692	0.757	0.757	0.757	0.757	0.232	0.464	0.557	0.299	0.1495	0.1246	
66 370	2	7	0.0974	0.292	3 045	1 082	230	0.00883	0.881	0.882	0.882	0.882	0.964	0.964	0.964	0.964	0.239	0.478	0.574	0.314	0.1570	0.1308	
66 370	2	3	0.1487	0.320	2 913	1 071	240	0.00903	0.873	0.873	0.873	0.873	0.955	0.955	0.955	0.955	0.238	0.476	0.571	0.307	0.1537	0.1281	
66 370	2	1	0.258	3 003	1 061	220	0.00836	0.864	0.864	0.864	0.864	0.945	0.945	0.945	0.945	0.242	0.484	0.581	0.323	0.1614	0.1345	
52 630	3	7	0.0867	0.260	2 433	858	200	0.00787	1.112	1.112	1.112	1.112	1.216	1.216	1.216	1.216	0.245	0.490	0.588	0.322	0.1611	0.1343	
52 630	3	3	0.1325	0.285	2 359	850	200	0.00805	1.101	1.101	1.101	1.101	1.204	1.204	1.204	1.204	0.244	0.488	0.585	0.316	0.1578	0.1315	
52 630	3	1	0.229	2 439	841	190	0.00745	1.090	1.090	1.090	1.090	1.192	1.192	1.192	1.192	0.248	0.496	0.595	0.331	0.1656	0.1380	
41 740	4	3	0.1180	0.254	1 879	674	180	0.00717	1.388	1.388	1.388	1.388	1.518	1.518	1.518	1.518	0.250	0.499	0.599	0.324	0.1619	0.1349	
41 740	4	1	0.204	1 970	667	170	0.00663	1.374	1.374	1.374	1.374	1.503	1.503	1.503	1.503	0.254	0.507	0.609	0.339	0.1697	0.1415	
33 100	5	3	0.1050	0.226	1 505	534	150	0.00638	1.750	1.750	1.750	1.750	1.914	1.914	1.914	1.914	0.256	0.511	0.613	0.352	0.1661	0.1384	
33 100	5	1	0.1519	1 591	529	140	0.00590	1.733	1.733	1.733	1.733	1.895	1.895	1.895	1.895	0.260	0.519	0.623	0.348	0.1738	0.1449	
26 250	6	3	0.0935	0.201	1 205	424	130	0.00568	2.21	2.21	2.21	2.21	2.41	2.41	2.41	2.41	0.262	0.523	0.628	0.341	0.1703	0.1419	
26 250	6	1	0.1620	1 280	420	120	0.00526	2.18	2.18	2.18	2.18	2.39	2.39	2.39	2.39	0.265	0.531	0.637	0.356	0.1779	0.1483	
20 820	7	1	0.1443	1 030	333	110	0.00468	2.75	2.75	2.75	2.75	3.01	3.01	3.01	3.01	0.271	0.542	0.651	0.364	0.1821	0.1517	
16 510	8	1	0.1285	826	284	90	0.00417	3.47	3.47	3.47	3.47	3.80	3.80	3.80	3.80	0.277	0.554	0.665	0.372	0.1862	0.1552	

*For conductor at 75°C., air at 25°C., wind 1.4 miles per hour (2 ft./sec), frequency—60 cycles.

Table 2—Characteristics of Aluminum Conductors, Hard Drawn, 61 Per Cent Conductivity
(Aluminum Company of America.)



Size of Conductor Circular Mils or A.W.G.	No. of Strands	Diameter of Individual Strands Inches	Outside Diameter Inches	Ultimate Strength Pounds	Weight Pounds Per Mile	Geometric Mean Radius at 60 Cycles Feet	Approx. Current Carrying Capacity* Amps	r_a Resistance Ohms Per Conductor Per Mile												X_a Inductive Reactance Ohms per Conductor Per Mile At 1 Ft. Spacing			X_c Shunt Capacitive Reactance Megohms Per Conductor Per Mile At 1 Ft. Spacing					
								25°C. (77°F.)						50°C. (122°F.)						25			50			60		
								d-c	25 cycles	50 cycles	60 cycles	d-c	25 cycles	50 cycles	60 cycles	25 cycles	50 cycles	60 cycles	25 cycles	50 cycles	60 cycles	25 cycles	50 cycles	60 cycles				
6	7	0.0612	0.184	528	130	0.00556	100	3.56	3.56	3.56	3.56	3.91	3.91	3.91	3.91	0.2626	0.5251	0.6301	0.3468	0.1734	0.1445							
4	7	0.0772	0.232	826	207	0.00700	134	2.24	2.24	2.24	2.24	2.46	2.46	2.46	2.46	0.2509	0.5017	0.6201	0.3302	0.1651	0.1378							
3	7	0.0867	0.260	1022	261	0.00787	155	1.77	1.77	1.77	1.77	1.95	1.95	1.95	1.95	0.2450	0.4899	0.5879	0.3221	0.1610	0.1342							
2	7	0.0974	0.292	1266	329	0.00883	180	1.41	1.41	1.41	1.41	1.55	1.55	1.55	1.55	0.2391	0.4782	0.5739	0.3139	0.1570	0.1308							
1	7	0.1094	0.328	1537	414	0.00992	209	1.12	1.12	1.12	1.12	1.23	1.23	1.23	1.23	0.2333	0.4665	0.5598	0.3055	0.1528	0.1273							
1/0	7	0.1228	0.368	1865	523	0.01113	242	0.885	0.885	0.885	0.885	0.973	0.973	0.973	0.973	0.2264	0.4528	0.5434	0.2976	0.1488	0.1240							
1/0	19	0.0745	0.373	2090	523	0.01177	244	0.885	0.885	0.885	0.885	0.973	0.973	0.973	0.973	0.2246	0.4492	0.5391	0.2890	0.1482	0.1235							
2/0	7	0.1379	0.414	2350	659	0.01251	282	0.702	0.702	0.702	0.702	0.771	0.771	0.771	0.771	0.2216	0.4431	0.5317	0.2864	0.1445	0.1204							
2/0	19	0.0837	0.419	2586	659	0.01321	283	0.702	0.702	0.702	0.702	0.771	0.771	0.771	0.771	0.2188	0.4376	0.5251	0.2882	0.1441	0.1201							
3/0	7	0.1548	0.464	2845	832	0.01404	327	0.557	0.557	0.557	0.557	0.612	0.612	0.612	0.612	0.2157	0.4314	0.5177	0.2810	0.1405	0.1171							
3/0	19	0.0940	0.470	3200	832	0.01483	328	0.557	0.557	0.557	0.557	0.612	0.612	0.612	0.612	0.2129	0.4258	0.5110	0.2801	0.1400	0.1167							
4/0	7	0.1739	0.522	3590	1049	0.01677	380	0.441	0.441	0.441	0.442	0.485	0.485	0.485	0.486	0.2099	0.4196	0.5036	0.2726	0.1363	0.1136							
4/0	19	0.1055	0.528	3890	1049	0.01666	381	0.441	0.441	0.441	0.442	0.485	0.485	0.485	0.486	0.2071	0.4141	0.4969	0.2717	0.1358	0.1132							
250 000	37	0.0822	0.575	4860	1239	0.01841	425	0.374	0.374	0.374	0.375	0.411	0.411	0.411	0.412	0.2020	0.4049	0.4848	0.2657	0.1328	0.1107							
266 800	7	0.1953	0.586	4525	1322	0.01771	441	0.350	0.350	0.350	0.351	0.385	0.385	0.385	0.386	0.2040	0.4079	0.4895	0.2642	0.1321	0.1101							
266 800	37	0.0849	0.594	5180	1322	0.01902	443	0.350	0.350	0.350	0.351	0.385	0.385	0.385	0.386	0.2004	0.4007	0.4809	0.2633	0.1316	0.1097							
300 000	19	0.1257	0.629	5300	1487	0.01983	478	0.311	0.311	0.311	0.312	0.342	0.342	0.342	0.343	0.1983	0.3965	0.4758	0.2592	0.1296	0.1080							
300 000	37	0.0900	0.630	5830	1487	0.02017	478	0.311	0.311	0.311	0.312	0.342	0.342	0.342	0.343	0.1974	0.3947	0.4737	0.2592	0.1296	0.1080							
338 400	19	0.1331	0.666	5940	1667	0.02100	514	0.278	0.278	0.278	0.279	0.306	0.306	0.306	0.307	0.1953	0.3907	0.4688	0.2551	0.1276	0.1063							
338 400	37	0.0954	0.668	6400	1667	0.02135	514	0.278	0.278	0.278	0.279	0.306	0.306	0.306	0.307	0.1945	0.3890	0.4668	0.2549	0.1274	0.1062							
350 000	37	0.0973	0.681	6680	1735	0.02178	528	0.267	0.267	0.267	0.268	0.294	0.294	0.294	0.295	0.1935	0.3870	0.4644	0.2537	0.1268	0.1057							
397 500	19	0.1447	0.724	6880	1967	0.02283	575	0.235	0.235	0.235	0.236	0.258	0.258	0.258	0.259	0.1911	0.3822	0.4587	0.2491	0.1246	0.1038							
477 000	19	0.1585	0.793	8090	2364	0.02501	649	0.196	0.196	0.196	0.198	0.215	0.215	0.215	0.216	0.1865	0.3730	0.4476	0.2429	0.1214	0.1012							
500 000	19	0.1623	0.812	8475	2478	0.02560	664	0.187	0.187	0.187	0.189	0.206	0.206	0.206	0.208	0.1853	0.3707	0.4448	0.2412	0.1208	0.1005							
500 000	37	0.1162	0.813	9010	2478	0.02603	664	0.187	0.187	0.187	0.189	0.206	0.206	0.206	0.208	0.1845	0.3689	0.4427	0.2410	0.1205	0.1004							
556 500	19	0.1711	0.856	9440	2758	0.02701	710	0.168	0.168	0.168	0.170	0.185	0.185	0.185	0.187	0.1826	0.3652	0.4383	0.2374	0.1187	0.0989							
636 000	37	0.1311	0.918	11240	3152	0.02936	776	0.147	0.147	0.147	0.149	0.162	0.162	0.162	0.164	0.1785	0.3569	0.4283	0.2323	0.1162	0.0968							
715 500	37	0.1391	0.974	12640	3546	0.03114	817	0.137	0.137	0.137	0.138	0.144	0.144	0.144	0.146	0.1764	0.3508	0.4210	0.2282	0.1141	0.0951							
750 000	37	0.1424	0.997	12980	3717	0.03188	864	0.125	0.125	0.125	0.127	0.137	0.137	0.137	0.139	0.1743	0.3485	0.4182	0.2266	0.1133	0.0944							
750 000	61	0.1109	0.998	13510	3717	0.03211	864	0.125	0.125	0.125	0.127	0.137	0.137	0.137	0.139	0.1739	0.3477	0.4173	0.2263	0.1132	0.0943							
795 000	37	0.1466	1.026	13770	3940	0.03283	897	0.117	0.117	0.117	0.120	0.129	0.129	0.129	0.131	0.1728	0.3455	0.4146	0.2244	0.1122	0.0935							
874 500	37	0.1558	1.077	14830	4334	0.03445	949	0.107	0.107	0.107	0.110	0.118	0.118	0.118	0.121	0.1703	0.3407	0.4088	0.2216	0.1105	0.0921							
954 000	37	0.1606	1.024	16180	4728	0.03596	1009	0.0979	0.098	0.098	0.100	0.109	0.109	0.109	0.111	0.1682	0.3363	0.4036	0.2179	0.1090	0.0908							
1 000 000	61	0.1280	1.152	17670	4956	0.03707	1030	0.0934	0.094	0.094	0.096	0.103	0.103	0.103	0.106	0.1666	0.3332	0.3998	0.2162	0.1081	0.0901							
1 000 000	91	0.1048	1.153	18380	4956	0.03720	1030	0.0934	0.094	0.094	0.096	0.103	0.103	0.103	0.106	0.1664	0.3328	0.3994	0.2160	0.1080	0.0900							
1 033 500	37	0.1672	1.170	18260	5122	0.03743	1050	0.0904	0.091	0.091	0.093	0.099	0.099	0.099	0.102	0.1661	0.3322	0.3987	0.2150	0.1075	0.0896							
1 113 000	61	0.1361	1.216	19660	5517	0.03910	1110	0.0839	0.084	0.084	0.087	0.092	0.092	0.095	0.095	0.1639	0.3278	0.3934	0.2124	0.1062	0.0885							
1 192 500	61	0.1398	1.258	21000	5908	0.04048	1160	0.0783	0.079	0.079	0.082	0.086	0.086	0.089	0.089	0.1622	0.3243	0.3892	0.2100	0.1050	0.0875							
1 192 500	91	0.1145	1.259	21400	5908	0.04062	1160	0.0783	0.079	0.079	0.082	0.086	0.086	0.089	0.089	0.1620	0.3240	0.3888	0.2098	0.1049	0.0874							
1 272 000	61	0.1444	1.300	22000	6299	0.04180	1210	0.0734	0.074	0.074	0.077	0.080	0.081	0.083	0.084	0.1606	0.3211	0.3863	0.2076	0.1038	0.0865							
1 351 500	61	0.1489	1.340	23400	6700	0.04309	1250	0.0691	0.069	0.069	0.073	0.076	0.077	0.079	0.079	0.1590	0.3180	0.3816	0.2054	0.1027	0.0858							
1 431 000	61	0.1532	1.379	24300	7091	0.04434	1300	0.0653	0.066	0.066	0.069	0.071	0.072	0.075	0.075	0.1576	0.3152	0.3782	0.2033	0.1016	0.0847							
1 510 500	61	0.1574	1.417	25800	7487	0.04556	1320	0.0618	0.062	0.062	0.065	0.067	0.068	0.070	0.072	0.1562	0.3123	0.3748	0.2014	0.1007	0.0839							
1 590 000	61	0.1615	1.454	27000	7883	0.04674	1380	0.0577	0.058	0.058	0.061	0.063	0.064	0.066	0.066	0.1549	0.3098	0.3718	0.1997	0.0998	0.0832							
1 590 000	91	0.1322	1.454	28100	7883	0.04691	1380	0.0587	0.059	0.059	0.062	0.063	0.064	0.066	0.066	0.1547	0.3094	0.3713	0.1997	0.0998	0.0832							

*For conductor at 75°C, wind 1.4 miles per hour (2 ft/sec), frequency=60 cycles.

Table 3—Characteristics of Aluminum Cable Steel Reinforced

(Aluminum Company of America)

Circular Mils or A.W.G. Alu- minum	Aluminum		Steel		Copper Equiva- lent* Circular Mils or A.W.G.	Ultimate Strength Pounds	Wt. Lbs. per Mile	Geo- metric Mean Radius at 60 Cycles Feet	Ap- prox. Cur- rent Car- rying Ca- pac- ity† Amps	R_a Resistance Ohms per Conductor per Mile												X_a Inductive Reactance Ohms per Conductor per Mile at 1 Ft. Spacing All Currents			X_c' Shunt Capacitive Reactance Megohms per Conductor per Mile at 1 Ft. Spacing		
	Strands	Layers	Strand Dia. Inches	Strand Dia. Inches						Outside Diameter Inches	25°C. (77°F.) Small Currents				50°C. (122°F.) Current Approx. 75% Capacity†				25 cycles	50 cycles	60 cycles	25 cycles	50 cycles	60 cycles			
											d-c	25 cycles	50 cycles	60 cycles	d-c	25 cycles	50 cycles	60 cycles									
											Single Layer Conductors																
										Small Currents						Current Ap- prox. 75% Capacity†											
										25 cycles	50 cycles	60 cycles	25 cycles	50 cycles	60 cycles	25 cycles	50 cycles	60 cycles	25 cycles	50 cycles	60 cycles	25 cycles	50 cycles	60 cycles			
1 590 000	54	3	0.1716	19.01030	1.545	1 000 000	56 000	10 777	0.0520	1 380	0.0587	0.0588	0.0590	0.0591	0.0646	0.0656	0.0675	0.0684	0.1495	0.299	0.359	0.1053	0.0977	0.0814			
1 510 500	54	3	0.1673	19.01004	1.506	950 000	53 200	10 237	0.0507	1 340	0.0618	0.0619	0.0621	0.0622	0.0680	0.0690	0.0710	0.0720	0.1508	0.302	0.362	0.1071	0.0986	0.0821			
1 431 000	54	3	0.1628	19.00977	1.465	900 000	50 400	9 699	0.0493	1 300	0.0652	0.0653	0.0655	0.0656	0.0718	0.0729	0.0749	0.0760	0.1522	0.304	0.365	0.1091	0.0996	0.0830			
1 352 000	54	3	0.1582	19.00949	1.424	850 000	47 600	9 160	0.0479	1 250	0.0691	0.0692	0.0694	0.0695	0.0761	0.0771	0.0792	0.0803	0.1536	0.307	0.369	0.201	0.1006	0.0838			
1 271 000	54	3	0.1535	19.00921	1.382	800 000	44 800	8 621	0.0465	1 200	0.0734	0.0735	0.0737	0.0738	0.0808	0.0819	0.0840	0.0851	0.1551	0.310	0.372	0.203	0.1016	0.0847			
1 192 500	54	3	0.1486	19.00892	1.338	750 000	43 100	8 082	0.0450	1 160	0.0783	0.0784	0.0786	0.0788	0.0862	0.0872	0.0894	0.0906	0.1568	0.314	0.376	0.206	0.1028	0.0857			
1 113 000	54	3	0.1436	19.00862	1.293	700 000	40 200	7 544	0.0435	1 110	0.0839	0.0840	0.0842	0.0844	0.0924	0.0935	0.0957	0.0969	0.1585	0.317	0.380	0.208	0.1040	0.0867			
1 033 500	54	3	0.1384	19.00831	1.248	650 000	37 100	7 019	0.0420	1 060	0.0903	0.0905	0.0907	0.0909	0.0994	0.1005	0.1025	0.1035	0.1603	0.321	0.385	0.211	0.1053	0.0878			
954 000	54	3	0.1328	19.00799	1.198	600 000	34 200	6 478	0.0403	1 010	0.0979	0.0980	0.0981	0.0982	0.1078	0.1088	0.1118	0.1128	0.1624	0.325	0.390	0.214	0.1068	0.0890			
900 000	54	3	0.1291	19.00769	1.162	550 000	32 300	6 112	0.0391	970	0.104	0.104	0.104	0.104	0.1145	0.1155	0.1175	0.1185	0.1639	0.328	0.393	0.216	0.1078	0.0898			
874 500	54	3	0.1273	19.00743	1.146	550 000	31 400	5 940	0.0385	950	0.107	0.107	0.107	0.108	0.1178	0.1188	0.1218	0.1228	0.1646	0.329	0.395	0.217	0.1083	0.0903			
795 000	54	3	0.1214	19.00711	1.093	500 000	28 500	5 399	0.0368	900	0.117	0.118	0.118	0.119	0.1288	0.1308	0.1358	0.1378	0.1670	0.334	0.401	0.220	0.1100	0.0917			
795 000	26	2	0.1749	7.01360	1.108	500 000	31 200	5 770	0.0375	900	0.117	0.117	0.117	0.117	0.1288	0.1288	0.1288	0.1288	0.1660	0.332	0.399	0.219	0.1095	0.0912			
795 000	30	3	0.1628	7.00977	1.140	500 000	38 400	6 517	0.0393	910	0.117	0.117	0.117	0.117	0.1288	0.1288	0.1288	0.1288	0.1637	0.327	0.393	0.217	0.1085	0.0904			
715 500	54	3	0.1151	7.01151	1.036	450 000	26 300	4 859	0.0349	830	0.131	0.131	0.131	0.132	0.1442	0.1452	0.1472	0.1482	0.1697	0.339	0.407	0.224	0.1119	0.0932			
715 500	26	2	0.1659	7.01280	1.051	450 000	28 100	5 193	0.0355	840	0.131	0.131	0.131	0.131	0.1442	0.1442	0.1442	0.1442	0.1687	0.337	0.405	0.223	0.1114	0.0928			
715 500	30	3	0.1544	7.00926	1.081	450 000	34 600	5 885	0.0372	840	0.131	0.131	0.131	0.131	0.1442	0.1442	0.1442	0.1442	0.1664	0.333	0.399	0.221	0.1104	0.0920			
666 000	54	3	0.1111	7.01111	1.000	419 000	24 500	4 627	0.0337	800	0.140	0.140	0.141	0.141	0.1541	0.1571	0.1591	0.1601	0.1715	0.343	0.412	0.226	0.1121	0.0920			
636 000	54	3	0.1085	7.01085	0.977	400 000	23 600	4 319	0.0329	770	0.147	0.147	0.148	0.148	0.1618	0.1638	0.1678	0.1688	0.1728	0.345	0.414	0.228	0.1140	0.0950			
636 000	26	2	0.1564	7.01216	0.990	400 000	25 000	4 616	0.0335	780	0.147	0.147	0.147	0.147	0.1618	0.1618	0.1618	0.1618	0.1718	0.344	0.412	0.227	0.1135	0.0946			
636 000	30	3	0.1456	7.00874	1.019	400 000	31 500	5 213	0.0351	780	0.147	0.147	0.147	0.147	0.1618	0.1618	0.1618	0.1618	0.1693	0.339	0.408	0.225	0.1125	0.0937			
605 000	54	3	0.1059	7.01059	0.953	380 500	22 500	4 109	0.0321	750	0.154	0.155	0.155	0.155	0.1695	0.1715	0.1755	0.1775	0.1739	0.348	0.417	0.230	0.1149	0.0957			
605 000	26	2	0.1525	7.01186	0.966	380 500	24 100	4 391	0.0327	760	0.154	0.154	0.154	0.154	0.1700	0.1720	0.1720	0.1720	0.1730	0.346	0.415	0.229	0.1144	0.0953			
556 500	26	2	0.1463	7.01138	0.927	350 000	22 400	4 039	0.0313	730	0.168	0.168	0.168	0.168	0.1849	0.1859	0.1859	0.1859	0.1751	0.350	0.420	0.232	0.1159	0.0965			
556 500	30	2	0.1362	7.01362	0.953	350 000	27 200	4 588	0.0328	730	0.168	0.168	0.168	0.168	0.1849	0.1859	0.1859	0.1859	0.1728	0.346	0.415	0.230	0.1149	0.0957			
500 000	30	2	0.1291	7.01291	0.904	314 500	24 400	4 122	0.0311	690	0.187	0.187	0.187	0.187	0.206				0.1754	0.351	0.421	0.234	0.1167	0.0973			
477 000	26	2	0.1355	7.01054	0.858	300 000	19 430	3 462	0.0290	670	0.196	0.196	0.196	0.196	0.216				0.1790	0.358	0.430	0.237	0.1186	0.0988			
477 000	30	2	0.1261	7.01261	0.853	300 000	23 300	3 933	0.0304	670	0.196	0.196	0.196	0.196	0.216				0.1766	0.353	0.424	0.235	0.1176	0.0980			
397 500	26	2	0.1226	7.00961	0.788	250 000	15 190	2 885	0.0265	590	0.235				0.259				0.1836	0.367	0.441	0.244	0.1219	0.1015			
397 500	30	2	0.1151	7.01151	0.806	250 000	19 980	3 277	0.0278	600	0.235				0.259				0.1812	0.362	0.435	0.242	0.1208	0.1006			
336 400	26	2	0.1138	7.00885	0.721	4/0	14 050	2 442	0.0244	530	0.278				0.306				0.1872	0.378	0.451	0.250	0.1248	0.1030			
336 400	30	2	0.1059	7.01059	0.741	4/0	17 040	2 774	0.0255	530	0.278				0.306				0.1855	0.371	0.445	0.248	0.1238	0.1032			
300 000	26	2	0.1074	7.00835	0.680	188 700	12 650	2 178	0.0230	490	0.311				0.342				0.1908	0.382	0.458	0.254	0.1269	0.1057			
300 000	30	2	0.1000	7.01000	0.700	188 700	15 430	2 473	0.0241	500	0.311				0.342				0.1883	0.377	0.452	0.252	0.1258	0.1049			
266 800	26	2	0.1013	7.00788	0.642	3/0	11 250	1 936	0.0217	460	0.350				0.385				0.1936	0.387	0.465	0.258	0.1289	0.1074			
										Single Layer Conductors																	
										Small Currents						Current Ap- prox. 75% Capacity†											
										25 cycles	50 cycles	60 cycles	25 cycles	50 cycles	60 cycles	25 cycles	50 cycles	60 cycles	25 cycles	50 cycles	60 cycles	25 cycles	50 cycles	60 cycles			
266 800	6	1	0.2109	7.00703	0.633	3/0	9 645	1 802	0.00684	460	0.351	0.351	0.351	0.352	0.386	0.430	0.510	0.552	0.194	0.388	0.466	0.252	0.504	0.605	0.259		
4/0	6	1	0.1878	10.1878	0.563	2/0	8 420	1 542	0.00814	340	0.441	0.442	0.444	0.445	0.485	0.514	0.567	0.592	0.218	0.437	0.524	0.242	0.484	0.581	0.267		
3/0	6	1	0.1672	10.1672	0.502	1/0	6 675	1 223	0.00600	300	0.556	0.557	0.559	0.560	0.612	0.642	0.697	0.723	0.225	0.450	0.540	0.259	0.517	0.621	0.275		
2/0	6	1	0.1490	10.1490	0.447	1	5 345	970	0.00510	270	0.702	0.702	0.704	0.706	0.773	0.806	0.866	0.895	0.231	0.462	0.554	0.267	0.534	0.641	0.284		
1/0	6	1																									

Table 4-A—Characteristics of Copperweld-Copper Conductors

(Copperweld Steel Company)



Nominal Designation	Size of Conductor		Copper Equivalent Circular Mils or A.W.G.	Rated Breaking Load Lbs.	Weight Lbs. per Mile	Geometric Mean Radius at 60 Cycles Feet	Approx. Current Carrying Capacity at 60 Cycles Amps*	r_a Resistance Ohms per Conductor per Mile at 25°C. (77°F.) Currents						r_a Resistance Ohms per Conductor per Mile at 50°C. (122°F.) Current Approx. 75% of Capacity**				x_a Inductive Reactance Ohms per Mile One ft. Spacing			x_a' Capacitive Reactance Megohms per Mile One ft. Spacing		
	Number and Diameter of Wires	Outside Diameter Inches						25 cycles			50 cycles			25 cycles			50 cycles			25	50	60	
								d-c	cycles	cycles	d-c	cycles	cycles	d-c	cycles	cycles	cycles	cycles	cycles	cycles	cycles	cycles	
350 E	7x.1576"	12x.1576"	0.788	350 000	32 420	7 400	0.2220	0.1658	0.1728	0.1789	0.1812	0.1812	0.1915	0.201	0.204	0.1929	0.386	0.463	0.243	0.1216	0.1014		
350 EK	4x.1470"	15x.1470"	0.735	350 000	23 850	6 536	0.0245	0.1658	0.1682	0.1700	0.1705	0.1812	0.1845	0.1873	0.1882	0.1875	0.375	0.450	0.248	0.1241	0.1034		
350 V	3x.1751"	9x.1833"	0.754	350 000	23 480	6 578	0.0226	0.1655	0.1725	0.1800	0.1828	0.1809	0.1910	0.202	0.206	0.1915	0.383	0.460	0.246	0.1232	0.1027		
300 E	7x.1459"	12x.1459"	0.729	300 000	27 770	6 351	0.0204	0.1934	0.200	0.207	0.209	0.211	0.222	0.232	0.235	0.1969	0.394	0.473	0.240	0.1244	0.1037		
300 EK	4x.1361"	15x.1361"	0.680	300 000	20 960	5 602	0.0227	0.1934	0.1958	0.1976	0.198	0.211	0.215	0.218	0.219	0.1914	0.383	0.460	0.254	0.1269	0.1057		
300 V	3x.1621"	9x.1752"	0.698	300 000	20 730	5 639	0.0209	0.1930	0.200	0.208	0.210	0.211	0.222	0.233	0.237	0.1954	0.391	0.469	0.252	0.1259	0.1050		
250 E	7x.1332"	12x.1332"	0.666	250 000	23 920	5 292	0.01859	0.232	0.239	0.245	0.248	0.254	0.265	0.275	0.279	0.202	0.403	0.484	0.255	0.1276	0.1064		
250 EK	4x.1242"	15x.1242"	0.621	250 000	17 840	4 669	0.0207	0.232	0.235	0.236	0.237	0.254	0.258	0.261	0.261	0.1960	0.392	0.471	0.260	0.1301	0.1084		
250 V	3x.1489"	9x.1600"	0.637	250 000	17 420	4 669	0.01911	0.232	0.239	0.246	0.248	0.254	0.264	0.276	0.281	0.200	0.400	0.480	0.258	0.1292	0.1077		
4/0 E	7x.1225"	12x.1225"	0.613	4/0	20 730	4 479	0.01711	0.274	0.281	0.287	0.290	0.300	0.312	0.323	0.326	0.206	0.411	0.493	0.261	0.1306	0.1088		
4/0 G	2x.1944"	5x.1944"	0.583	4/0	15 640	4 168	0.01409	0.273	0.284	0.294	0.298	0.299	0.318	0.336	0.342	0.215	0.431	0.517	0.265	0.1324	0.1103		
4/0 EK	4x.1143"	15x.1143"	0.571	4/0	15 370	3 951	0.01903	0.274	0.278	0.278	0.279	0.300	0.304	0.307	0.308	0.200	0.401	0.481	0.266	0.1331	0.1109		
4/0 V	3x.1361"	9x.1472"	0.586	4/0	15 000	3 977	0.01758	0.274	0.281	0.288	0.291	0.299	0.311	0.323	0.328	0.204	0.400	0.490	0.264	0.1322	0.1101		
4/0 F	1x.1833"	6x.1833"	0.560	4/0	12 290	3 760	0.01558	0.273	0.280	0.285	0.287	0.299	0.309	0.318	0.322	0.210	0.421	0.505	0.269	0.1344	0.1220		
3/0 E	7x.1091"	12x.1091"	0.545	3/0	18 800	3 552	0.01521	0.346	0.353	0.359	0.361	0.378	0.391	0.402	0.407	0.212	0.423	0.508	0.270	0.1348	0.1123		
3/0 J	3x.1851"	4x.1851"	0.555	3/0	16 170	3 732	0.01156	0.344	0.356	0.367	0.372	0.377	0.398	0.419	0.428	0.225	0.451	0.541	0.281	0.1341	0.1118		
3/0 G	2x.1731"	2x.1731"	0.519	3/0	12 860	3 305	0.01254	0.344	0.355	0.365	0.369	0.377	0.397	0.416	0.423	0.221	0.443	0.531	0.273	0.1365	0.1143		
3/0 EK	4x.1018"	4x.1018"	0.509	3/0	12 370	3 134	0.01697	0.346	0.348	0.350	0.351	0.378	0.382	0.386	0.386	0.206	0.412	0.495	0.274	0.1372	0.1137		
3/0 V	3x.1311"	9x.1311"	0.522	3/0	12 220	3 154	0.01566	0.345	0.352	0.360	0.362	0.377	0.390	0.403	0.408	0.210	0.420	0.504	0.273	0.1363	0.1136		
3/0 F	1x.1632"	6x.1632"	0.490	3/0	9 820	2 974	0.01388	0.344	0.351	0.356	0.358	0.377	0.388	0.397	0.401	0.216	0.432	0.510	0.277	0.1385	0.1155		
2/0 K	4x.1780"	3x.1780"	0.534	2/0	17 600	3 411	0.00912	0.434	0.447	0.459	0.466	0.475	0.499	0.524	0.535	0.237	0.475	0.570	0.271	0.1355	0.1129		
2/0 J	3x.1648"	4x.1648"	0.494	2/0	13 430	2 980	0.01029	0.434	0.446	0.457	0.462	0.475	0.498	0.520	0.530	0.231	0.463	0.555	0.277	0.1383	0.1152		
2/0 G	2x.1542"	5x.1542"	0.463	2/0	10 510	2 622	0.01119	0.434	0.445	0.456	0.459	0.475	0.497	0.518	0.525	0.227	0.454	0.545	0.281	0.1406	0.1171		
2/0 V	3x.1089"	9x.1187"	0.465	2/0	9 846	2 502	0.01395	0.435	0.442	0.450	0.452	0.476	0.489	0.504	0.509	0.216	0.432	0.518	0.281	0.1404	0.1170		
2/0 F	1x.1454"	6x.1454"	0.436	2/0	8 094	2 359	0.01235	0.434	0.441	0.446	0.448	0.475	0.487	0.497	0.501	0.222	0.444	0.533	0.285	0.1427	0.1189		
1/0 K	4x.1585"	3x.1585"	0.475	1/0	14 490	2 703	0.00812	0.548	0.560	0.573	0.579	0.599	0.625	0.652	0.664	0.243	0.487	0.584	0.279	0.1397	0.1164		
1/0 J	3x.1467"	4x.1467"	0.440	1/0	10 970	2 346	0.00917	0.548	0.559	0.570	0.576	0.599	0.624	0.648	0.659	0.237	0.474	0.569	0.285	0.1423	0.1186		
1/0 G	2x.1373"	5x.1373"	0.412	1/0	8 563	2 078	0.00966	0.548	0.559	0.568	0.573	0.599	0.623	0.645	0.654	0.233	0.466	0.559	0.289	0.1447	0.1206		
1/0 F	1x.1294"	6x.1294"	0.388	1/0	6 536	1 870	0.01099	0.548	0.554	0.559	0.562	0.599	0.612	0.622	0.627	0.228	0.456	0.547	0.294	0.1469	0.1252		
1 N	5x.1546"	2x.1546"	0.464	1	15 410	2 541	0.00638	0.691	0.705	0.719	0.726	0.755	0.787	0.818	0.832	0.256	0.512	0.614	0.281	0.1405	0.1171		
1 K	4x.1412"	3x.1412"	0.423	1	11 900	2 144	0.00723	0.691	0.704	0.716	0.722	0.755	0.784	0.813	0.825	0.249	0.498	0.598	0.288	0.1438	0.1198		
1 J	3x.1307"	4x.1307"	0.392	1	9 000	1 851	0.00817	0.691	0.703	0.714	0.719	0.755	0.783	0.808	0.820	0.243	0.486	0.583	0.293	0.1465	0.1211		
1 G	2x.1222"	5x.1222"	0.367	1	6 956	1 649	0.00887	0.691	0.702	0.712	0.718	0.755	0.781	0.805	0.815	0.239	0.478	0.573	0.298	0.1488	0.1240		
1 F	1x.1153"	6x.1153"	0.346	1	5 266	1 483	0.00980	0.691	0.698	0.704	0.705	0.755	0.769	0.781	0.786	0.234	0.468	0.561	0.302	0.1509	0.1258		
2 P	6x.1540"	1x.1540"	0.462	2	16 870	2 487	0.00501	0.871	0.886	0.901	0.909	0.952	0.988	1.024	1.040	0.268	0.536	0.643	0.281	0.1406	0.1172		
2 N	5x.1377"	2x.1377"	0.413	2	12 680	2 015	0.00568	0.871	0.885	0.899	0.902	0.952	0.986	1.020	1.035	0.261	0.523	0.627	0.289	0.1446	0.1205		
2 K	4x.1257"	3x.1257"	0.377	2	9 730	1 701	0.00644	0.871	0.884	0.896	0.902	0.952	0.983	1.014	1.028	0.255	0.510	0.612	0.296	0.1479	0.1232		
2 J	3x.1164"	4x.1164"	0.349	2	7 322	1 476	0.00727	0.871	0.883	0.894	0.899	0.952	0.982	1.010	1.022	0.249	0.498	0.598	0.301	0.1506	0.1255		
2 G	1x.1699"	2x.1699"	0.366	2	5 876	1 356	0.00763	0.869	0.875	0.880	0.882	0.950	0.962	0.973	0.979	0.247	0.493	0.592	0.298	0.1480	0.1241		
2 A	2x.1089"	6x.1089"	0.327	2	5 626	1 307	0.00790	0.871	0.882	0.892	0.896	0.952	0.980	1.006	1.016	0.245	0.489	0.587	0.306	0.1529	0.1275		
2 F	1x.1026"	6x.1026"	0.308	2	4 233	1 176	0.00873	0.871	0.878	0.884	0.885	0.952	0.967	0.979	0.985	0.230	0.479	0.575	0.310	0.1551	0.1292		
3 P	6x.1371"	1x.1371"	0.411	3	13 910	1 973	0.00445	1.098	1.113	1.127	1.136	1.200	1.239	1.273	1.296	0.274	0.547	0.657	0.290	0.1448	0.1207		
3 N	5x.1226"	2x.1226"	0.368	3	10 390	1 598	0.00506	1.098	1.112	1.126	1.133	1.200	1.237	1.273	1.298	0.267	0.534	0.641	0.296	0.1487	0.1239		
3 J	4x.1120"	3x.1120"	0.336	3	7 910	1 349	0.00574	1.098	1.111	1.123	1.129	1.200	1.233	1.267	1.291	0.261	0.522	0.628	0.304	0.1520	0.1298		
3 G	3x.1036"	4x.1036"	0.311	3	5 955	1 171	0.00648	1.098	1.110	1.121	1.126	1.200	1.232	1.262	1.275	0.255	0.509						

Table 4-B—Characteristics of Copperweld Conductors
(Copperweld Steel Company)

Nominal Conductor Size	Number and Size of Wires	Outside Diameter Inches	Area of Conductor Circular Mils	Rated Breaking Load Pounds		Weight Pounds per Mile	Geometric Mean Radius at 60 cycles and Average Currents Feet	Approx. Current Carrying Capacity* Amps at 60 Cycles	r_a Resistance Ohms per Conductor per Mile at 25°C. (77°F.) Small Currents			r_a Resistance Ohms per Conductor per Mile at 75°C. (167°F.) Current Approx. 75% of Capacity**				x_a Inductive Reactance Ohms per Conductor per Mile One Ft. Spacing Average Currents			x_a' Capacitive Reactance Megohms per Conductor per Mile One Ft. Spacing			
				Strength					d-c	25 cycles	50 cycles	60 cycles	d-c	25 cycles	50 cycles	60 cycles	25 cycles	50 cycles	60 cycles	25 cycles	50 cycles	60 cycles
				High	Extra High																	
30% Conductivity																						
7/8"	19 No. 5	0.910	628 900	55 570	66 910	9 344	0.00758	620	0.306	0.316	0.326	0.331	0.363	0.419	0.476	0.499	0.261	0.493	0.592	0.233	0.1165	0.0971
13/16"	19 No. 6	0.810	498 800	45 830	55 530	7 410	0.00675	540	0.386	0.398	0.406	0.411	0.458	0.518	0.580	0.605	0.267	0.505	0.606	0.241	0.1206	0.1005
23/32"	19 No. 7	0.721	395 500	37 740	45 850	5 877	0.00601	470	0.486	0.496	0.506	0.511	0.577	0.643	0.710	0.737	0.273	0.517	0.621	0.250	0.1248	0.1040
21/32"	19 No. 8	0.642	313 700	31 040	37 690	4 660	0.00535	410	0.613	0.623	0.633	0.638	0.728	0.799	0.872	0.902	0.279	0.529	0.635	0.258	0.1289	0.1074
9/16"	19 No. 9	0.572	248 800	25 500	30 610	3 696	0.00477	360	0.773	0.783	0.793	0.798	0.917	0.995	1.075	1.106	0.285	0.541	0.649	0.266	0.1330	0.1109
5/8"	7 No. 4	0.613	292 200	24 780	29 430	4 324	0.00511	410	0.656	0.664	0.672	0.676	0.778	0.824	0.870	0.887	0.281	0.533	0.640	0.261	0.1306	0.1088
9/16"	7 No. 5	0.546	231 700	20 470	24 650	3 429	0.00455	360	0.827	0.835	0.843	0.847	0.981	1.030	1.080	1.099	0.287	0.545	0.654	0.269	0.1347	0.1122
9/16"	7 No. 6	0.486	183 800	16 890	20 460	2 719	0.00405	310	1.042	1.050	1.058	1.062	1.237	1.290	1.343	1.364	0.293	0.557	0.668	0.278	0.1388	0.1157
7/16"	7 No. 7	0.433	145 700	13 910	16 890	2 157	0.00361	270	1.315	1.323	1.331	1.335	1.560	1.617	1.675	1.697	0.299	0.569	0.683	0.286	0.1429	0.1191
3/8"	7 No. 8	0.385	115 600	11 440	13 890	1 710	0.00321	230	1.658	1.666	1.674	1.678	1.967	2.03	2.09	2.12	0.305	0.581	0.697	0.294	0.1471	0.1226
11/32"	7 No. 9	0.343	91 650	9 393	11 280	1 356	0.00288	200	2.09	2.10	2.11	2.11	2.48	2.55	2.61	2.64	0.311	0.592	0.711	0.303	0.1512	0.1260
5/16"	7 No. 10	0.306	72 680	7 758	9 196	1 076	0.00255	170	2.64	2.64	2.65	2.66	3.13	3.20	3.27	3.30	0.316	0.604	0.725	0.311	0.1553	0.1294
3 No. 5	3 No. 5	0.392	99 310	9 282	11 860	1 467	0.00457	220	1.926	1.931	1.936	1.938	2.29	2.31	2.34	2.35	0.289	0.545	0.654	0.293	0.1465	0.1221
3 No. 6	3 No. 6	0.349	78 750	7 639	9 754	1 163	0.00407	190	2.43	2.43	2.44	2.44	2.88	2.91	2.94	2.95	0.295	0.556	0.668	0.301	0.1506	0.1255
3 No. 7	3 No. 7	0.311	62 450	6 291	7 922	922.4	0.00363	160	3.06	3.07	3.07	3.07	3.63	3.66	3.70	3.71	0.301	0.568	0.682	0.310	0.1547	0.1289
3 No. 8	3 No. 8	0.277	49 530	5 174	6 282	731.5	0.00323	140	3.86	3.87	3.87	3.87	4.58	4.61	4.65	4.66	0.307	0.580	0.696	0.318	0.1589	0.1324
3 No. 9	3 No. 9	0.247	39 280	4 250	5 129	580.1	0.00288	120	4.87	4.87	4.88	4.88	5.78	5.81	5.85	5.86	0.313	0.591	0.710	0.326	0.1629	0.1358
3 No. 10	3 No. 10	0.220	31 150	3 509	4 160	460.0	0.00257	110	6.14	6.14	6.15	6.15	7.28	7.32	7.36	7.38	0.319	0.603	0.724	0.334	0.1671	0.1392
40% Conductivity																						
7/8"	19 No. 5	0.910	628 900	50 240	9 344	0.01175	690	0.229	0.239	0.249	0.254	0.272	0.321	0.371	0.391	0.236	0.449	0.539	0.233	0.1165	0.0971
13/16"	19 No. 6	0.810	498 800	41 600	7 410	0.01046	610	0.289	0.299	0.309	0.314	0.343	0.396	0.450	0.472	0.241	0.461	0.553	0.241	0.1206	0.1005
23/32"	19 No. 7	0.721	395 500	34 390	5 877	0.00931	530	0.365	0.375	0.385	0.390	0.433	0.490	0.549	0.573	0.247	0.473	0.567	0.250	0.1248	0.1040
21/32"	19 No. 8	0.642	313 700	28 380	4 660	0.00829	470	0.460	0.470	0.480	0.485	0.546	0.608	0.672	0.698	0.253	0.485	0.582	0.258	0.1289	0.1074
9/16"	19 No. 9	0.572	248 800	23 300	3 696	0.00739	410	0.580	0.590	0.600	0.605	0.688	0.756	0.826	0.753	0.259	0.496	0.595	0.266	0.1330	0.1109
5/8"	7 No. 4	0.613	292 200	22 310	4 324	0.00792	470	0.492	0.500	0.508	0.512	0.584	0.624	0.664	0.680	0.255	0.489	0.587	0.261	0.1306	0.1088
9/16"	7 No. 5	0.546	231 700	18 510	3 429	0.00705	410	0.620	0.628	0.636	0.640	0.736	0.780	0.843	0.840	0.261	0.501	0.601	0.269	0.1347	0.1122
1/2"	7 No. 6	0.486	183 800	15 330	2 719	0.00628	350	0.782	0.790	0.798	0.802	0.928	0.975	1.021	1.040	0.267	0.513	0.615	0.278	0.1388	0.1157
7/16"	7 No. 7	0.433	145 700	12 670	2 157	0.00559	310	0.986	0.994	1.002	1.006	1.170	1.220	1.271	1.291	0.273	0.524	0.629	0.286	0.1429	0.1191
3/8"	7 No. 8	0.385	115 600	10 460	1 710	0.00497	270	1.244	1.252	1.260	1.264	1.476	1.530	1.584	1.606	0.279	0.536	0.644	0.294	0.1471	0.1226
11/32"	7 No. 9	0.343	91 650	8 616	1 356	0.00443	230	1.568	1.576	1.584	1.588	1.861	1.919	1.978	2.00	0.285	0.548	0.658	0.303	0.1512	0.1260
5/16"	7 No. 10	0.306	72 680	7 121	1 076	0.00395	200	1.978	1.986	1.994	1.998	2.35	2.41	2.47	2.50	0.291	0.559	0.671	0.311	0.1553	0.1294
3 No. 5	3 No. 5	0.392	99 310	8 373	1 467	0.00621	250	1.445	1.450	1.455	1.457	1.714	1.738	1.762	1.772	0.269	0.514	0.617	0.293	0.1465	0.1221
3 No. 6	3 No. 6	0.349	78 750	6 934	1 163	0.00553	220	1.821	1.826	1.831	1.833	2.16	2.19	2.21	2.22	0.275	0.526	0.631	0.301	0.1506	0.1255
3 No. 7	3 No. 7	0.311	62 450	5 732	922.4	0.00492	190	2.30	2.30	2.31	2.31	2.73	2.75	2.78	2.79	0.281	0.537	0.645	0.310	0.1547	0.1289
3 No. 8	3 No. 8	0.277	49 530	4 730	731.5	0.00439	160	2.90	2.90	2.91	2.91	3.44	3.47	3.50	3.51	0.286	0.549	0.659	0.318	0.1589	0.1324
3 No. 9	3 No. 9	0.247	39 280	3 898	580.1	0.00391	140	3.65	3.66	3.66	3.66	4.33	4.37	4.40	4.41	0.292	0.561	0.673	0.326	0.1629	0.1358
3 No. 10	3 No. 10	0.220	31 150	3 221	460.0	0.00348	120	4.61	4.61	4.62	4.62	5.46	5.50	5.53	5.55	0.297	0.572	0.687	0.334	0.1671	0.1392
3 No. 12	3 No. 12	0.174	19 590	2 236	289.3	0.00276	90	7.32	7.33	7.33	7.34	8.69	8.73	8.77	8.78	0.310	0.596	0.715	0.351	0.1754	0.1462

*Based on conductor temperature of 125°C. and an ambient of 25°C.
 **Resistance at 75°C. total temperature, based on an ambient of 25°C. plus 50°C. rise due to heating effect of current.
 The approximate magnitude of current necessary to produce the 50°C. rise is 75% of the "Approximate Current Carrying Capacity at 60 Cycles."

Table 5—60-Cycle Characteristics of Three-Conductor Belted Paper-Insulated Cables

Voltage Class	Insulation Thickness		AWG (B&S) or MCM	Type of Conductor (5)	Weight per 1000 Ft. Aluminum	Weight per 1000 Ft. Copper	Diameter or Sector Depth	POSITIVE & NEGATIVE SEQUENCE										ZERO SEQUENCE				LEAD SHEATH	
	Conductor	Belt						Resistance (1) Ohms/Mi. Aluminum	Resistance (1) Ohms/Mi. Copper	GMR of one Conductor (2) Inches	Series Resistance Ohms/Mile	Shunt Capacitive Reactance (3) Ohms for 1 Mi.	GMR Three Conductors	Series Resistance (4) Ohm/Mile		Series Resistance (4) Ohms/Mile	Shunt Capacitive Reactance (3) Ohms for 1 Mi.	Thickness Mils	Resistance Ohms/MI. at 80° C.				
														Aluminum	Copper								
1,000 Volts Grounded or Ungrounded	55	35	6	CR	1290	1460	.184	4.13	2.52	0.067	0.181	6000	0.180	12.47	10.86	.311	11,300	85	2.78				
	55	35	4	CR	1490	1760	.232	2.58	1.58	0.084	0.170	5200	0.212	9.54	8.54	.298	10,000	90	2.32				
	55	35	2	CR	1880	2310	.292	1.64	1.01	0.106	0.162	4500	0.258	7.76	7.13	.274	8,700	90	2.04				
	55	35	1	CR	2180	2720	.332	1.29	0.800	0.126	0.152	4200	0.291	6.66	6.17	.256	8,000	95	1.79				
	55	35	0	CR	2400	3090	.373	1.03	0.638	0.142	0.146	3900	0.322	6.01	5.82	.246	7,700	95	1.66				
	55	35	00	CS	2260	3120	.323	0.816	0.511	0.151	0.132	2400	0.270	6.41	6.09	.271	4,700	95	1.86				
	55	35	0000	CS	2520	3610	.364	0.650	0.410	0.171	0.132	2100	0.296	5.81	5.57	.285	4,300	95	1.72				
	55	35	0000	CS	2960	4330	.417	0.518	0.328	0.191	0.130	1900	0.331	5.02	4.83	.255	3,900	100	1.50				
	55	35	250	CS	3220	4840	.455	0.443	0.280	0.210	0.127	1700	0.356	4.70	4.54	.248	3,500	100	1.42				
	55	35	300	CS	3650	5600	.497	0.368	0.236	0.230	0.128	1500	0.383	4.18	4.04	.246	3,200	105	1.27				
	55	35	350	CS	3970	6240	.539	0.318	0.204	0.249	0.125	1400	0.410	3.89	3.77	.242	2,900	105	1.19				
	55	35	400	CS	4240	6830	.572	0.282	0.182	0.265	0.123	1300	0.432	3.73	3.63	.236	2,700	105	1.15				
55	35	500	CS	4970	8220	.642	0.230	0.150	0.297	0.121	1200	0.477	3.23	3.15	.233	2,400	110	1.00					
65	40	600	CS	5850	9750	.706	0.195	0.128	0.327	0.123	1200	0.526	2.82	2.753	.221	2,500	115	0.875					
65	40	700	CS	6550	11100	.754	0.172	0.112	0.353	0.121	1100	0.561	2.55	2.49	.229	2,200	120	0.794					
65	40	750	CS	6900	11750	.780	0.162	0.107	0.366	0.120	1100	0.578	2.47	2.42	.228	1,900	120	0.770					
3,000 Volts Grounded or Ungrounded	70	40	6	CR	1500	1670	.184	4.13	2.52	0.067	0.192	6700	0.192	11.30	9.69	0.322	12,500	90	2.39				
	70	40	4	CR	1740	2010	.232	2.58	1.58	0.084	0.181	5800	0.227	9.06	8.06	0.298	11,200	90	2.16				
	70	40	2	CR	2130	2560	.292	1.64	1.01	0.106	0.171	5100	0.271	7.04	6.41	0.280	9,800	95	1.80				
	70	40	1	CR	2340	2880	.332	1.29	0.800	0.126	0.161	4700	0.304	6.33	5.84	0.263	9,200	95	1.68				
	70	40	0	CR	2670	3360	.373	1.03	0.638	0.142	0.156	4400	0.335	5.47	5.08	0.256	8,600	100	1.48				
	70	40	00	CS	2440	3300	.323	0.816	0.511	0.151	0.142	3500	0.285	6.02	5.70	0.275	6,700	95	1.73				
	70	40	0000	CS	2690	3780	.364	0.650	0.410	0.171	0.138	2700	0.312	5.54	5.30	0.266	5,100	95	1.63				
	70	40	0000	CS	3050	4420	.417	0.518	0.328	0.191	0.135	2400	0.347	4.78	4.59	0.258	4,600	100	1.42				
	70	40	250	CS	3530	5150	.455	0.443	0.280	0.210	0.132	2100	0.372	4.25	4.09	0.254	4,200	105	1.27				
	70	40	300	CS	3860	5810	.497	0.368	0.236	0.230	0.130	1900	0.398	3.97	3.84	0.252	3,800	105	1.20				
	70	40	350	CS	4180	6450	.539	0.318	0.204	0.249	0.129	1800	0.425	3.74	3.62	0.244	3,700	105	1.14				
	70	40	400	CS	4640	7230	.572	0.282	0.182	0.265	0.128	1700	0.448	3.43	3.33	0.242	3,400	110	1.05				
70	40	500	CS	5350	8600	.642	0.230	0.150	0.297	0.126	1500	0.493	2.98	2.90	0.238	3,000	115	0.918					
75	40	600	CS	5990	9890	.700	0.195	0.128	0.327	0.125	1400	0.537	2.76	2.69	0.232	2,800	115	0.855					
75	40	700	CS	6750	11300	.754	0.170	0.112	0.353	0.123	1300	0.572	2.49	2.43	0.230	2,600	120	0.775					
75	40	750	CS	7050	11900	.780	0.162	0.107	0.366	0.123	1300	0.588	2.44	2.38	0.229	2,500	120	0.758					
5,000 Volts Grounded or Ungrounded	85	45	6	CR	1630	1800	.184	4.13	2.52	0.067	0.203	7500	0.196	10.79	9.18	0.342	13,400	90	2.22				
	85	45	4	CR	2130	2400	.232	2.58	1.58	0.084	0.190	6600	0.238	8.58	7.58	0.308	12,100	90	2.00				
	85	45	2	CR	2380	2810	.292	1.64	1.01	0.106	0.178	5800	0.283	6.71	6.08	0.287	10,700	95	1.69				
	85	45	1	CR	2580	3120	.332	1.29	0.800	0.126	0.168	5300	0.317	5.79	5.30	0.270	10,000	100	1.50				
	85	45	0	CR	2860	3550	.373	1.03	0.638	0.142	0.160	5000	0.347	5.26	4.87	0.260	9,300	100	1.41				
	85	45	00	CS	2590	3450	.323	0.816	0.511	0.151	0.148	3600	0.299	5.75	5.43	0.279	6,900	95	1.64				
	85	45	0000	CS	2950	4040	.364	0.650	0.410	0.171	0.143	3200	0.326	5.00	4.76	0.273	6,100	100	1.45				
	85	45	0000	CS	3300	4670	.417	0.518	0.328	0.191	0.141	2800	0.362	4.54	4.35	0.260	5,600	100	1.34				
	85	45	250	CS	3700	5320	.455	0.443	0.280	0.210	0.138	2600	0.388	4.07	3.91	0.258	5,200	105	1.21				
	85	45	300	CS	4010	5960	.497	0.368	0.236	0.230	0.135	2400	0.414	3.82	3.69	0.252	4,600	105	1.15				
	85	45	350	CS	4490	6760	.539	0.318	0.204	0.249	0.133	2200	0.442	3.44	3.32	0.248	4,200	110	1.04				
	85	45	400	CS	4820	7410	.572	0.282	0.182	0.265	0.131	2000	0.465	3.28	3.18	0.244	4,000	110	1.00				
85	45	500	CS	5530	8780	.642	0.230	0.150	0.297	0.129	1800	0.510	2.88	2.80	0.238	3,500	115	0.885					
85	45	600	CS	6300	10200	.700	0.195	0.128	0.327	0.128	1600	0.548	2.59	2.52	0.236	3,200	120	0.798					
85	45	700	CS	6850	11400	.754	0.170	0.112	0.353	0.126	1500	0.583	2.42	2.36	0.234	2,900	120	0.750					
85	45	750	CS	7300	12150	.780	0.162	0.107	0.366	0.125	1500	0.600	2.28	2.22	0.232	2,700	125	0.707					
8,000 Volts Grounded	105	55	6	CR	1930	2100	.184	4.13	2.52	0.067	0.216	8500	0.211	9.80	8.19	0.354	14,900	95	1.89				
	105	55	4	CR	2200	2470	.232	2.58	1.58	0.084	0.201	7400	0.254	7.77	6.77	0.318	13,400	95	1.73				
	105	55	2	CR	2690	3120	.292	1.64	1.01	0.106	0.189	6500	0.299	6.08	5.45	0.296	12,000	100	1.48				
	105	55	1	CR	2840	3380	.332	1.29	0.800	0.126	0.177	6000	0.333	5.46	4.97	0.282	11,200	100	1.39				
	105	55	0	CR	3200	3890	.373	1.03	0.638	0.142	0.169	5600	0.364	4.75	4.36	0.272	10,500	105	1.24				
	105	55	00	CS	2930	3790	.323	0.816	0.511	0.151	0.156	4300	0.320	5.12	4.80	0.285	8,300	100	1.43				
	105	55	0000	CS	3220	4310	.364	0.650	0.410	0.171	0.151	3800	0.348	4.67	4.43	0.277	7,400	100	1.34				
	105	55	0000	CS	3680	5050	.417	0.518	0.328	0.191	0.147	3500	0.383	4.07	3.90	0.270	6,600	105	1.19				
	105	55	250	CS	4000	5620	.455	0.443	0.280	0.210	0.144	3200	0.407	3.83	3.67	0.265	6,100	105	1.13				
	105	55	300	CS	4460	6410	.497	0.368	0.236	0.230	0.141	2900	0.434	3.46	3.33	0.260	5,600	110	1.03				
	105	55	350	CS	4780	7050	.539	0.318	0.204	0.249	0.139	2700	0.463	3.25	3.14	0.254	5,200	110	0.978				
	105	55	400	CS	5270	7860	.572	0.282	0.182	0.265	0.137	2500	0.486	2.98	2.88	0.250	4,900	115	0.899				
105	55	500	CS	6040	9290	.642	0.230	0.150	0.297	0.135	2200	0.529											

Table 5—60-Cycle Characteristics of Three-Conductor Belted Paper-Insulated Cables (Concluded)

Voltage Class	Insulation Thickness		AWG (B&S) or MCM	Type of Conductor (5)	Weight per 1000 Ft. Aluminum	Weight per 1000 Ft. Copper	Diameter or Sector Depth	Resistance (1) Ohms/Mi. Aluminum	Resistance (1) Ohms/Mi. Copper	GMR of one Conductor (2) Inches	POSITIVE & NEGATIVE SEQUENCE		ZERO SEQUENCE				LEAD SHEATH		
	Conductor	Belt									Series Resistance (4) Ohm/Mile	Shunt Capacitive Reactance (3) Ohms for 1 Mi.	Aluminum	Copper	Series Reactance (4) Ohms/Mile	Shunt Capacitive Reactance (3) Ohms for 1 Mi.	Thickness Mils	Resistance Ohms/MI. at 50°C.	
																			Series Reactance Ohms/Mile
8,000 Volts Ungrounded	105	105	6	CR	2170	2340	.184	4.13	2.52	0.067	0.216	9000	0.211	9.32	7.71	0.384	17,600	95	1.73
	105	105	4	CR	2690	2960	.232	2.58	1.58	0.084	0.201	7900	0.254	7.14	6.14	0.348	15,900	100	1.52
	105	105	2	CR	2720	3150	.292	1.64	1.01	0.106	0.189	6900	0.299	5.78	5.15	0.322	14,100	100	1.38
	105	105	1	CR	3340	3880	.332	1.29	0.800	0.126	0.177	6400	0.333	4.98	4.49	0.308	13,200	105	1.23
	105	105	0	CR	3590	4280	.373	1.03	0.638	0.142	0.169	6000	0.364	4.36	3.97	0.294	12,500	105	1.11
	105	105	00	CS	3330	4190	.323	0.816	0.511	0.151	0.156	5000	0.320	4.61	4.29	0.312	10,300	105	1.19
	105	105	0000	CS	3620	4710	.364	0.650	0.410	0.171	0.151	4500	0.348	4.22	3.98	0.302	9,500	105	1.19
	105	105	0000	CS	4120	5490	.417	0.518	0.328	0.191	0.147	4100	0.383	3.70	3.51	0.292	8,700	110	1.06
	105	105	250	CS	4410	6030	.455	0.443	0.280	0.210	0.144	3800	0.407	3.47	3.31	0.286	8,000	110	1.01
	105	105	300	CS	4920	6870	.497	0.368	0.236	0.230	0.141	3500	0.434	3.15	3.02	0.280	7,400	115	0.928
	105	105	350	CS	5270	7540	.539	0.318	0.204	0.249	0.139	3300	0.463	2.97	2.86	0.274	7,000	115	0.884
	105	105	400	CS	5610	8200	.572	0.282	0.182	0.265	0.137	3100	0.486	2.85	2.75	0.268	6,600	115	0.856
	105	105	500	CS	6390	9640	.642	0.230	0.150	0.297	0.135	2800	0.529	2.52	2.44	0.264	6,000	120	0.764
	105	105	600	CS	7150	11050	.700	0.195	0.128	0.327	0.132	2600	0.569	2.28	2.21	0.258	5,400	125	0.694
	105	105	700	CS	7750	12300	.754	0.170	0.112	0.353	0.130	2300	0.605	2.15	2.09	0.254	5,000	125	0.660
105	105	750	CS	8280	13150	.780	0.162	0.107	0.366	0.129	2200	0.621	2.02	1.97	0.252	4,600	130	0.620	
15,000 Volts Grounded	170	75	4	CR	3010	3280	.232	2.58	1.58	0.084	0.232	9600	0.302	6.27	5.27	0.348	16,400	105	1.23
	170	75	2	CR	3270	3700	.292	1.64	1.01	0.106	0.216	8400	0.349	5.06	4.43	0.318	14,700	105	1.14
	170	75	1	CR	3920	4460	.332	1.29	0.800	0.126	0.202	7700	0.384	4.38	3.89	0.304	13,900	110	1.03
	155	75	0	CR	4200	4890	.373	1.03	0.638	0.142	0.188	6900	0.405	4.09	3.70	0.289	12,700	110	1.02
	155	75	00	CR	4630	5490	.419	0.816	0.511	0.159	0.185	6500	0.439	3.57	3.26	0.280	12,000	115	0.918
	155	75	000	CR	4830	5920	.470	0.650	0.410	0.178	0.180	6100	0.476	3.25	3.01	0.272	11,300	115	0.867
	155	75	0000	CS	4580	5950	.417	0.518	0.328	0.191	0.161	4800	0.430	3.44	3.25	0.283	9,000	110	0.973
	155	75	250	CS	5040	6660	.455	0.443	0.280	0.210	0.155	4500	0.457	3.11	2.95	0.276	8,200	115	0.890
	155	75	300	CS	5400	7350	.497	0.368	0.236	0.230	0.153	4200	0.484	2.93	2.80	0.271	7,900	115	0.855
	155	75	350	CS	5900	8170	.539	0.318	0.204	0.249	0.150	4000	0.512	2.67	2.56	0.267	7,200	120	0.784
	155	75	400	CS	6260	8850	.572	0.282	0.182	0.265	0.146	3700	0.536	2.56	2.46	0.262	6,900	120	0.758
	155	75	500	CS	7110	10350	.642	0.230	0.150	0.297	0.144	3300	0.580	2.27	2.19	0.258	6,200	125	0.680
	155	75	600	CS	7900	11800	.700	0.195	0.128	0.327	0.141	3000	0.620	2.06	1.99	0.253	5,700	130	0.620
	155	75	700	CS	8500	13050	.754	0.170	0.112	0.353	0.139	2700	0.657	1.94	1.88	0.249	5,400	130	0.591
	155	75	750	CS	9090	13950	.780	0.162	0.107	0.366	0.138	2600	0.681	1.84	1.78	0.243	5,100	135	0.558
15,000 Volts Ungrounded	170	155	4	CR	3610	3880	.232	2.58	1.58	0.084	0.232	10300	0.302	5.76	4.76	0.378	18,900	110	1.06
	170	155	2	CR	4010	4280	.292	1.64	1.01	0.106	0.216	9000	0.349	4.61	3.98	0.353	17,200	110	0.990
	170	155	1	CR	4580	5120	.332	1.29	0.800	0.126	0.202	8400	0.384	3.99	3.50	0.336	16,400	115	0.900
	155	155	0	CR	4730	5420	.373	1.03	0.638	0.142	0.188	7600	0.405	3.70	3.31	0.320	15,300	115	0.890
	155	155	00	CR	4990	5850	.419	0.816	0.511	0.159	0.185	7000	0.439	3.36	3.05	0.310	14,400	115	0.846
	155	155	000	CR	5550	6640	.470	0.650	0.410	0.178	0.180	6600	0.476	2.95	2.71	0.300	13,600	120	0.768
	155	155	0000	CS	5000	6370	.417	0.518	0.328	0.191	0.161	5600	0.430	3.08	2.89	0.314	11,600	115	0.855
	155	155	250	CS	5730	7350	.455	0.443	0.280	0.210	0.155	5200	0.457	2.80	2.64	0.307	10,800	120	0.786
	155	155	300	CS	6120	8070	.497	0.368	0.236	0.230	0.153	4900	0.484	2.63	2.50	0.301	10,200	120	0.755
	155	155	350	CS	6670	8940	.539	0.318	0.204	0.249	0.150	4600	0.512	2.41	2.30	0.294	9,500	125	0.698
	155	155	400	CS	7050	9640	.572	0.282	0.182	0.265	0.146	4300	0.536	2.31	2.21	0.288	9,000	125	0.676
	155	155	500	CS	7910	11150	.642	0.230	0.150	0.297	0.144	3900	0.580	2.06	1.98	0.283	8,200	130	0.611
	155	155	600	CS	8750	12650	.700	0.195	0.128	0.327	0.141	3600	0.620	1.87	1.80	0.277	7,500	135	0.558
	155	155	700	CS	9400	13950	.754	0.170	0.112	0.353	0.139	3400	0.657	1.78	1.71	0.272	7,200	135	0.535
	155	155	750	CS	9760	14600	.780	0.162	0.107	0.366	0.138	3300	0.681	1.74	1.68	0.266	6,800	135	0.525

(1) A-C resistance based on 65°C. with allowance for stranding, skin effect and proximity effect. Copper 0.15328 ohm (meter, gram); aluminum 0.076397 ohm (meter, gram).
 (2) GMR of sector shaped conductors is an approximate figure close enough for most practical applications.

(3) Dielectric constant assumed 3.7.
 (4) Zero-sequence impedances based on all return current in the sheath; none in the ground.
 (5) The following symbols are used to designate the conductor type—CR—concentric round; CS—compact sector.

Table 6—60-Cycle Characteristics of Three-Conductor Shielded Paper-Insulated Cables

Voltage Class Phase to Phase	Insulation Thickness Mils	M-Circular Mils or AWG (B & S)	Type of Conductor (5)	Weight Per 1000 Ft.—Copper	Weight Per 1000 Ft.—Aluminum	Diameter or Sector Depth Inches	Copper Resistance (1) Ohms Per Mile—65°C	Aluminum Resistance (1) Ohms Per Mile—65°C	GMR of One Conductor (2) Inches	POSITIVE AND NEGATIVE SEQUENCE			ZERO SEQUENCE				SHEATH		Approximate Overall Diameter—Inches
										Series Resistance Ohms Per Mile	Shunt Capacitive (3) Reactance—Ohms Per Mile	GMR—Three Conductors	Cu Series Resistance Ohms Per Mile $r_s + 3r_e$	Aluminum Series Resistance (4) Ohms Per Mile	Series Resistance ($r_s - 2r_e - 3r_e$) Ohms Per Mile	Shunt Capacitive (3) Reactance—Ohms Per Mile	Thickness Mils	Resistance—Ohms Per Mile—50°C	
15000 (grounded)	190 4	CR	3480	3210	0.232	1.572	2.582	0.084	0.240	7810	0.316	5.29	6.30	0.322	7810	105	1.24	1.64	
	190 2	CR	4130	3700	0.292	1.901	1.630	0.106	0.224	6700	0.364	4.48	5.11	0.296	6700	105	1.160	1.75	
	175 1	CR	4320	3780	0.332	0.795	1.290	0.126	0.204	5800	0.389	4.02	4.51	0.282	5800	110	1.075	1.80	
	175 1/0	CR	4840	4150	0.373	0.629	1.025	0.141	0.200	5310	0.419	3.69	4.09	0.275	5310	110	1.020	1.89	
	175 2/0	CS	4650	3790	0.323	0.510	0.810	0.151	0.177	4200	0.357	3.93	4.23	0.305	4200	105	1.140	1.77	
	175 3/0	CS	5350	4260	0.364	0.407	0.648	0.171	0.170	3720	0.384	3.53	3.77	0.300	3720	110	1.040	1.86	
	175 4/0	CS	5990	4620	0.417	0.326	0.515	0.191	0.166	3360	0.420	3.26	3.45	0.289	3360	110	0.978	1.97	
	175 250	CS	6740	5120	0.455	0.278	0.440	0.210	0.161	3250	0.445	2.96	3.12	0.284	3250	115	0.892	2.06	
	175 300	CS	7430	5480	0.497	0.234	0.368	0.230	0.157	3060	0.475	2.79	2.93	0.278	3060	115	0.855	2.15	
	175 350	CS	8700	6000	0.539	0.202	0.318	0.249	0.154	2895	0.502	2.54	2.66	0.274	2895	120	0.781	2.25	
	175 400	CS	8940	6350	0.572	0.181	0.281	0.265	0.152	2580	0.525	2.46	2.56	0.267	2580	120	0.761	2.31	
	175 500	CS	10450	7200	0.642	0.149	0.228	0.297	0.147	2460	0.570	2.19	2.27	0.262	2460	125	0.680	2.47	
	175 600	CS	11900	8000	0.700	0.127	0.194	0.327	0.145	2380	0.610	2.00	2.06	0.256	2380	130	0.622	2.60	
	175 700	CS	13200	8650	0.754	0.112	0.172	0.353	0.141	2260	0.647	1.90	1.96	0.251	2260	130	0.595	2.72	
	175 750	CS	14050	9200	0.780	0.106	0.161	0.366	0.140	2140	0.665	1.79	1.84	0.250	2140	135	0.560	2.78	
15000 (ungrounded)	230 4	CR	3980	3710	0.232	1.572	2.582	0.084	0.255	8850	0.344	4.75	5.76	0.334	8850	110	1.060	1.83	
	230 2	CR	4620	4190	0.292	1.901	1.630	0.106	0.238	7650	0.392	3.94	4.57	0.314	7650	110	0.981	1.96	
	230 1	CR	5170	4630	0.332	0.795	1.290	0.126	0.222	7000	0.430	3.50	3.99	0.295	7000	115	0.900	2.05	
	215 1/0	CR	5410	4720	0.373	0.629	1.025	0.141	0.212	6150	0.450	3.29	3.69	0.284	6150	115	0.885	2.08	
	215 2/0	CS	5360	4500	0.323	0.510	0.810	0.151	0.188	4680	0.386	3.45	3.75	0.318	4680	110	0.981	1.96	
	215 3/0	CS	6040	4590	0.364	0.407	0.648	0.171	0.181	4350	0.415	3.11	3.35	0.308	4350	115	0.900	2.05	
	215 4/0	CS	6720	5350	0.410	0.326	0.515	0.191	0.176	4030	0.446	2.89	3.08	0.300	4030	115	0.855	2.15	
	215 250	CS	7480	5860	0.447	0.278	0.440	0.210	0.171	3620	0.473	2.62	2.78	0.290	3620	120	0.780	2.23	
	215 300	CS	8230	6280	0.490	0.234	0.368	0.230	0.167	3500	0.500	2.51	2.65	0.286	3500	120	0.760	2.32	
	215 350	CS	9070	6800	0.532	0.202	0.318	0.249	0.162	3380	0.531	2.29	2.41	0.279	3380	125	0.696	2.42	
	215 400	CS	9780	7190	0.566	0.181	0.281	0.265	0.159	3220	0.555	2.26	2.30	0.274	3220	125	0.675	2.49	
	215 500	CS	11350	8100	0.635	0.149	0.228	0.297	0.155	2900	0.600	1.98	2.06	0.272	2900	130	0.610	2.65	
	215 600	CS	12800	8900	0.690	0.127	0.194	0.327	0.152	2740	0.638	1.81	1.87	0.265	2740	135	0.560	2.78	
	215 700	CS	14100	9550	0.742	0.112	0.172	0.353	0.147	2620	0.675	1.72	1.78	0.260	2620	135	0.538	2.89	
	215 750	CS	14800	9950	0.767	0.106	0.161	0.366	0.146	2500	0.698	1.69	1.74	0.255	2500	135	0.528	2.94	
23000 (grounded)	255 2	CR	5090	4660	0.292	1.901	1.630	0.106	0.246	8250	0.410	3.671	4.300	0.316	8250	115	0.890	2.07	
	255 1	CR	5480	4940	0.332	0.795	1.290	0.126	0.230	7550	0.448	3.345	3.840	0.300	7550	115	0.850	2.16	
	255 1/0	CR	6310	5620	0.373	0.629	1.025	0.141	0.223	6970	0.480	2.969	3.365	0.292	6970	120	0.779	2.28	
	240 2/0	CS	5880	5020	0.323	0.510	0.810	0.151	0.195	5000	0.405	3.170	3.470	0.322	5000	115	0.885	2.08	
	240 3/0	CS	6390	5300	0.364	0.407	0.648	0.171	0.187	4845	0.435	2.957	3.198	0.310	4845	115	0.850	2.16	
	240 4/0	CS	7260	5890	0.410	0.326	0.515	0.191	0.181	4350	0.465	2.646	2.835	0.305	4350	120	0.775	2.27	
	240 250	CS	7870	6250	0.447	0.278	0.440	0.210	0.176	3950	0.493	2.518	2.680	0.298	3950	120	0.746	2.35	
	240 300	CS	8770	6820	0.490	0.234	0.368	0.230	0.171	3870	0.517	2.294	2.428	0.293	3870	125	0.687	2.45	
	240 350	CS	9480	7210	0.532	0.202	0.318	0.249	0.167	3540	0.556	2.190	2.306	0.284	3540	125	0.662	2.54	
	240 400	CS	10400	7810	0.566	0.181	0.281	0.265	0.164	3460	0.572	2.031	2.131	0.282	3460	130	0.617	2.62	
	240 500	CS	12000	8750	0.635	0.149	0.228	0.297	0.159	3220	0.620	1.829	1.908	0.275	3220	135	0.560	2.78	
	240 600	CS	13250	9350	0.690	0.127	0.194	0.327	0.155	3060	0.656	1.738	1.805	0.271	3060	135	0.538	2.89	
	240 700	CS	14800	10250	0.742	0.112	0.172	0.353	0.151	2900	0.695	1.611	1.671	0.265	2900	140	0.499	3.01	
	240 750	CS	15450	10600	0.767	0.106	0.161	0.366	0.151	2740	0.710	1.605	1.661	0.265	2740	140	0.500	3.07	
	23000 (ungrounded)	310 2	CR	5980	5550	0.292	1.901	1.630	0.106	0.262	9440	0.446	3.281	3.910	0.328	9440	120	0.756	2.32
310 1		CR	6580	6040	0.332	0.795	1.290	0.126	0.244	8450	0.486	2.885	3.380	0.312	8450	125	0.696	2.42	
310 1/0		CR	7470	6780	0.373	0.629	1.025	0.141	0.238	7980	0.518	2.639	3.035	0.304	7980	125	0.670	2.51	
310 2/0		CR	7810	6950	0.419	0.510	0.810	0.151	0.228	7350	0.554	2.360	2.660	0.295	7350	130	0.617	2.62	
310 3/0		CS	7750	6660	0.364	0.407	0.648	0.171	0.202	5900	0.482	2.427	2.668	0.298	5490	125	0.672	2.50	
310 4/0		CS	8790	7420	0.410	0.326	0.515	0.191	0.195	5000	0.516	2.191	2.380	0.318	5000	130	0.621	2.61	
310 250		CS	9390	7770	0.447	0.278	0.440	0.210	0.190	4700	0.544	2.078	2.240	0.312	4700	130	0.600	2.69	
310 300		CS	10350	8400	0.490	0.234	0.368	0.230	0.185	4510	0.575	1.909	2.043	0.305	4510	135	0.561	2.79	
310 350		CS	11100	8830	0.532	0.202	0.318	0.249	0.180	4350	0.604	1.822	1.938	0.298	4350	135	0.540	2.88	
310 400		CS	11850	9260	0.566	0.181	0.281	0.265	0.176	4100	0.629	1.761	1.861	0.293	4100	135	0.528	2.95	
310 500		CS	13450	10200	0.635	0.149	0.228	0.297	0.170	3870	0.675	1.594	1.673	0.286	3870	140	0.481	3.11	
310 600		CS	15050	11150	0.690	0.127	0.194	0.327	0.166	3620	0.713	1.467	1.534	0.280	3620	145	0.446	3.23	
310 700		CS	16450	11900	0.742	0.112	0.172	0.353	0.161	3460	0.750	1.412	1.472	0.275	3460	145	0.423	3.34	
310 750		CS	17350	12500	0.767	0.106	0.161	0.366	0.161	3380	0.779	1.309	1.364	0.269	3380	150	0.409	3.41	
35000 (grounded)		345 2/0	CR	8550	7690	0.419	0.510	0.810	0.151	0									

Table 7—60-Cycle Characteristics of Single-Conductor Concentric-Strand Paper-Insulated Cables

Voltage Class	Insulation Thickness—Mils	Conductor Size AWC (B & S) or Thousand Circular Mils	Weight Per 1000 Ft. Copper Conductor	Weight Per 1000 Ft. Aluminum Conductor	Diameter of Conductor—Inches	GMR of One Conductor—Inches	x_a	x_b	r_a	r_a	r_s	Shunt Capacitive Reactance—Ohms Per Phase Per Mile	Lead Sheath Thickness—Mils
							Resistance at 12 Inches—Ohms Per Phase Per Mile	Resistance of Sheath—Ohms Per Phase Per Mile	Resistance of Copper Conductor—Ohms Per Phase Per Mile	Resistance of Aluminum Conductor—Ohms Per Phase Per Mile	Resistance of Sheath—Ohms Per Phase Per Mile at 50°C		
1000 (grounded or ungrounded)	60	6	570	510	0.184	0.067	0.630	0.487	2.504	4.132	6.130	4048.	75
	60	4	665	575	0.232	0.084	0.602	0.473	1.572	2.599	5.498	3361.	75
	60	2	820	680	0.292	0.106	0.574	0.458	0.993	1.637	4.545	2776.	80
	60	1	930	750	0.332	0.126	0.553	0.450	0.786	1.293	4.237	2488.	80
	60	1/0	1050	820	0.373	0.141	0.539	0.442	0.621	1.030	3.968	2249.	80
	60	2/0	1240	950	0.418	0.159	0.525	0.432	0.494	0.816	3.676	2031.	80
	60	3/0	1440	1080	0.470	0.178	0.511	0.423	0.392	0.644	3.201	1833.	85
	60	4/0	1690	1240	0.528	0.200	0.497	0.413	0.311	0.513	2.960	1651.	85
	60	250	1910	1370	0.575	0.221	0.485	0.406	0.264	0.435	2.785	1528.	85
	60	300	2170	1530	0.630	0.242	0.474	0.399	0.221	0.363	2.629	1406.	85
	60	350	2420	1870	0.681	0.262	0.464	0.392	0.189	0.311	2.339	1309.	90
	60	400	2680	1820	0.728	0.280	0.456	0.386	0.166	0.272	2.222	1230.	90
	60	500	3170	2090	0.814	0.312	0.443	0.376	0.134	0.219	2.058	1110.	90
	60	600	3670	2380	0.893	0.345	0.431	0.367	0.112	0.183	1.897	1017.	95
	60	750	4370	2760	0.998	0.385	0.417	0.356	0.091	0.147	1.651	916.	95
	60	1000	5480	3330	1.152	0.445	0.400	0.342	0.070	0.111	1.399	799.	100
	75	1250	6600	3910	1.289	0.499	0.386	0.328	0.058	0.091	1.187	888.	105
	75	1500	7690	4470	1.412	0.546	0.375	0.319	0.050	0.077	1.051	814.	110
	75	1750	8880	5120	1.526	0.592	0.365	0.311	0.044	0.067	0.983	756.	110
	75	2000	9870	5570	1.632	0.633	0.357	0.304	0.040	0.060	0.890	709.	115
3000 (grounded or ungrounded)	75	6	610	550	0.184	0.067	0.630	0.478	2.504	4.132	5.735	4807.	75
	75	4	700	610	0.232	0.084	0.602	0.466	1.572	2.599	5.178	4021.	75
	75	2	850	710	0.292	0.106	0.574	0.452	0.993	1.637	4.310	3343.	80
	75	1	970	790	0.332	0.126	0.553	0.444	0.786	1.293	4.032	3006.	80
	75	1/0	1120	890	0.373	0.141	0.539	0.436	0.621	1.030	3.788	2725.	80
	75	2/0	1280	990	0.418	0.159	0.525	0.427	0.494	0.816	3.521	2467.	80
	75	3/0	1490	1130	0.470	0.178	0.511	0.418	0.392	0.644	3.076	2233.	85
	75	4/0	1750	1300	0.528	0.200	0.497	0.409	0.311	0.513	2.852	2016.	85
	75	250	1970	1430	0.575	0.221	0.485	0.402	0.264	0.435	2.689	1869.	85
	75	300	2250	1610	0.630	0.242	0.474	0.394	0.221	0.363	2.389	1722.	90
	75	350	2520	1770	0.681	0.262	0.464	0.388	0.189	0.311	2.268	1605.	90
	75	400	2790	1930	0.728	0.280	0.456	0.382	0.166	0.272	2.157	1511.	90
	75	500	3270	2190	0.814	0.312	0.443	0.372	0.134	0.219	1.888	1365.	95
	75	600	3740	2450	0.893	0.345	0.431	0.364	0.112	0.183	1.762	1252.	95
	75	750	4430	2820	0.998	0.385	0.417	0.353	0.091	0.147	1.527	1129.	100
	75	1000	5540	3390	1.152	0.445	0.400	0.340	0.070	0.111	1.370	987.	100
	90	1250	6650	3960	1.289	0.499	0.386	0.326	0.058	0.091	1.165	1054.	105
	90	1500	7810	4590	1.412	0.546	0.375	0.317	0.050	0.077	1.033	967.	110
	90	1750	8940	5180	1.526	0.592	0.365	0.309	0.044	0.067	0.923	899.	115
	90	2000	9970	5670	1.632	0.633	0.357	0.302	0.040	0.060	0.876	844.	115
5000 (grounded or ungrounded)	90	6	650	590	0.184	0.067	0.630	0.471	2.504	4.132	5.387	5501.	75
	90	4	750	660	0.232	0.084	0.602	0.458	1.572	2.599	4.545	4631.	80
	90	2	910	770	0.292	0.106	0.574	0.446	0.993	1.637	4.098	3872.	80
	90	1	1040	860	0.332	0.126	0.553	0.438	0.786	1.293	3.846	3493.	80
	90	1/0	1180	950	0.373	0.141	0.539	0.431	0.621	1.030	3.623	3175.	80
	90	2/0	1360	1070	0.418	0.159	0.525	0.421	0.494	0.816	3.158	2882.	85
	90	3/0	1570	1210	0.470	0.178	0.511	0.413	0.392	0.644	2.960	2614.	85
	90	4/0	1830	1380	0.528	0.200	0.497	0.405	0.311	0.513	2.752	2365.	85
	90	250	2030	1490	0.575	0.221	0.485	0.398	0.264	0.435	2.600	2196.	85
	90	300	2320	1680	0.630	0.242	0.474	0.391	0.221	0.363	2.315	2026.	90
	90	350	2590	1840	0.681	0.262	0.464	0.384	0.189	0.311	2.200	1891.	90
	90	400	2860	2000	0.728	0.280	0.456	0.378	0.166	0.272	2.096	1781.	90
	90	500	3330	2260	0.814	0.312	0.443	0.369	0.134	0.219	1.839	1613.	95
	90	600	3810	2520	0.893	0.345	0.431	0.361	0.112	0.183	1.719	1481.	95
	90	750	4510	2900	0.998	0.385	0.417	0.350	0.091	0.147	1.493	1337.	100
	90	1000	5840	3490	1.152	0.445	0.400	0.337	0.070	0.111	1.274	1171.	105
	100	1250	6830	4140	1.289	0.499	0.386	0.324	0.058	0.091	1.151	1163.	105
	100	1500	7940	4720	1.412	0.546	0.375	0.316	0.050	0.077	1.021	1068.	110
	100	1750	9070	5310	1.526	0.592	0.365	0.307	0.044	0.067	0.913	993.	115
	100	2000	10140	5840	1.632	0.633	0.357	0.301	0.040	0.060	0.867	932.	115

Table 7 continued on next page

Table 7—60-Cycle Characteristics of Single-Conductor Concentric-Strand Paper-Insulated Cables (Continued)

Voltage Class	Insulation Thickness Mils	Conductor Size AWG (B & S) or Thousand Circular Mills	Weight Per 1000 Ft. Copper Conductor	Weight Per 1000 Ft. Aluminum Conductor	Diameter of Conductor—Inches	G.M.R. of One Conductor—Inches	r_a	r_b	r_c	Resistance		Shunt Capacitive Reactance—Ohms Per Phase Per Mile	Lead Sheath Thickness—Mils
										of Copper Conductor—Ohms Per Phase Per Mile	of Aluminum Conductor—Ohms Per Phase Per Mile		
8000 (grounded)	130	6	825	770	0.184	0.067	0.630	0.452	2.504	4.132	4.310	7103.	80
	130	4	930	840	0.232	0.084	0.602	0.442	1.572	2.599	3.968	6061.	80
	115	2	1080	940	0.292	0.106	0.574	0.436	0.993	1.637	3.788	4684.	80
	115	1	1220	1040	0.332	0.126	0.553	0.429	0.786	1.293	3.571	4244.	80
	115	1/0	1350	1120	0.373	0.141	0.539	0.421	0.621	1.030	3.158	3873.	85
	115	2/0	1530	1240	0.418	0.159	0.525	0.413	0.494	0.816	2.980	3558.	85
	115	3/0	1730	1370	0.470	0.178	0.511	0.408	0.392	0.644	2.785	3212.	85
	115	4/0	1980	1530	0.528	0.200	0.497	0.398	0.311	0.513	2.600	2915.	85
	115	250	2190	1660	0.575	0.221	0.485	0.391	0.264	0.435	2.315	2713.	90
	115	300	2480	1840	0.630	0.242	0.474	0.384	0.221	0.363	2.200	2509.	90
	115	350	2740	1990	0.681	0.262	0.464	0.378	0.189	0.311	2.096	2346.	90
	115	400	3020	2160	0.728	0.280	0.456	0.373	0.166	0.272	2.002	2214.	90
	115	500	3430	2350	0.814	0.312	0.443	0.364	0.134	0.219	1.762	2008.	95
	115	600	3930	2640	0.893	0.345	0.431	0.356	0.112	0.183	1.651	1848.	95
	115	750	4700	3090	0.998	0.385	0.417	0.346	0.091	0.147	1.439	1672.	100
	115	1000	5800	3710	1.152	0.445	0.400	0.333	0.070	0.111	1.233	1468.	105
	115	1250	7060	4370	1.289	0.499	0.386	0.322	0.058	0.091	1.076	1324.	110
	115	1500	8160	4940	1.412	0.546	0.375	0.314	0.050	0.077	1.005	1217.	110
	115	1750	9250	5490	1.526	0.592	0.365	0.305	0.044	0.067	0.899	1132.	115
	115	2000	10240	5950	1.632	0.633	0.357	0.299	0.040	0.060	0.855	1063.	115
8000 (ungrounded)	155	6	910	850	0.184	0.067	0.630	0.442	2.504	4.132	3.968	7963.	80
	155	4	1010	920	0.232	0.084	0.602	0.432	1.572	2.599	3.676	6842.	80
	140	2	1170	1030	0.292	0.106	0.574	0.427	0.993	1.637	3.521	5421.	80
	140	1	1300	1120	0.332	0.126	0.553	0.420	0.786	1.293	3.116	4931.	85
	140	1/0	1430	1200	0.373	0.141	0.539	0.413	0.621	1.030	2.960	4515.	85
	140	2/0	1620	1330	0.418	0.159	0.525	0.406	0.494	0.816	2.785	4127.	85
	140	3/0	1870	1510	0.470	0.178	0.511	0.399	0.392	0.644	2.629	3768.	85
	140	4/0	2090	1640	0.528	0.200	0.497	0.391	0.311	0.513	2.315	3431.	90
	140	250	2320	1780	0.575	0.221	0.485	0.384	0.264	0.435	2.200	3199.	90
	140	300	2620	1980	0.630	0.242	0.474	0.378	0.221	0.363	2.096	2965.	90
	140	350	2890	2140	0.681	0.262	0.464	0.372	0.189	0.311	1.888	2777.	95
	140	400	3170	2310	0.728	0.280	0.456	0.367	0.166	0.272	1.807	2624.	95
	140	500	3670	2600	0.814	0.312	0.443	0.359	0.134	0.219	1.691	2386.	95
	140	600	4170	2880	0.893	0.345	0.431	0.351	0.112	0.183	1.504	2199.	100
	140	750	4970	3360	0.998	0.385	0.417	0.341	0.091	0.147	1.389	1994.	100
	140	1000	6120	3970	1.152	0.445	0.400	0.329	0.070	0.111	1.194	1754.	105
	140	1250	7210	4530	1.289	0.499	0.386	0.318	0.058	0.091	1.045	1585.	110
	140	1500	8380	5160	1.412	0.546	0.375	0.310	0.050	0.077	.978	1459.	110
	140	1750	9540	5780	1.526	0.592	0.365	0.302	0.044	0.067	.876	1358.	115
	140	2000	10590	6290	1.632	0.633	0.357	0.298	0.040	0.060	.797	1277.	120
15000 (grounded)	190	4	1220	1120	0.232	0.084	0.602	0.420	1.572	2.599	3.116	7821.	85
	190	2	1370	1230	0.292	0.106	0.574	0.410	0.993	1.637	2.887	6721.	85
	175	1	1480	1300	0.332	0.126	0.553	0.409	0.786	1.293	2.852	5805.	85
	175	1/0	1610	1380	0.373	0.141	0.539	0.403	0.621	1.030	2.720	5336.	85
	175	2/0	1770	1480	0.418	0.159	0.525	0.396	0.494	0.816	2.572	4896.	85
	175	3/0	1980	1620	0.470	0.178	0.511	0.389	0.392	0.644	2.291	4488.	90
	175	4/0	2250	1800	0.528	0.200	0.497	0.382	0.311	0.513	2.157	4100.	90
	175	250	2480	1940	0.575	0.221	0.485	0.376	0.264	0.435	2.058	3833.	90
	175	300	2770	2130	0.630	0.242	0.474	0.370	0.221	0.363	1.855	3563.	95
	175	350	3080	2330	0.681	0.262	0.464	0.365	0.189	0.311	1.777	3344.	95
	175	400	3380	2520	0.728	0.280	0.456	0.360	0.166	0.272	1.705	3165.	95
	175	500	3900	2825	0.814	0.312	0.443	0.352	0.134	0.219	1.515	2887.	100
	175	600	4380	3090	0.893	0.345	0.431	0.345	0.112	0.183	1.429	2666.	100
	175	750	5150	3540	0.998	0.385	0.417	0.335	0.091	0.147	1.257	2424.	105
	175	1000	6300	4150	1.152	0.445	0.400	0.324	0.070	0.111	1.144	2139.	105
	175	1250	7490	4800	1.289	0.499	0.386	0.314	0.058	0.091	1.005	1937.	110
	175	1500	8600	5380	1.412	0.546	0.375	0.305	0.050	0.077	0.899	1786.	115
	175	1750	9820	6060	1.526	0.592	0.365	0.298	0.044	0.067	0.846	1665.	115
	175	2000	10900	6630	1.632	0.633	0.357	0.292	0.040	0.060	0.772	1567.	120

Table 7 continued on next page

Table 7—60-Cycle Characteristics of Single-Conductor Concentric-Strand Paper-Insulated Cables (Continued)

Voltage Class	Insulation Thickness Mils	Conductor Size AWG (B & S) or Thousand Circular Mils	Weight Per 1000 Ft. Copper Conductor	Weight Per 1000 Ft. Aluminum Conductor	Diameter of Conductor—Inches	GMR of One Conductor—Inches	Reactance at 60 Cycles Per Phase Per Mile	Reactance of Sheath at 60 Cycles Per Phase Per Mile	r _a		Resistance of Sheath at 60 Cycles Per Phase Per Mile	Resistance of Aluminum Conductor at 60 Cycles Per Phase Per Mile	Shunt Capacitive Reactance—Ohms Per Phase Per Mile	Lead Sheath Thickness—Mils
									CU	AL				
15000 (ungrounded)	230	4	1370	1280	0.232	0.084	0.602	0.407	1.572	2.599	2.818	8812.	85	
	230	2	1510	1370	0.292	0.106	0.574	0.399	0.993	1.637	2.629	7628.	85	
	230	1	1630	1450	0.332	0.126	0.553	0.393	0.786	1.293	2.364	7010.	90	
	215	1/0	1770	1540	0.373	0.141	0.539	0.392	0.621	1.030	2.339	6183.	90	
	215	2/0	1940	1650	0.418	0.159	0.525	0.386	0.494	0.816	2.222	5694.	90	
	215	3/0	2140	1780	0.470	0.178	0.511	0.380	0.392	0.644	2.116	5238.	90	
	215	4/0	2420	1970	0.528	0.200	0.497	0.373	0.311	0.513	2.002	4804.	90	
	215	250	2650	2110	0.575	0.221	0.485	0.367	0.264	0.435	1.807	4502.	95	
	215	300	2960	2320	0.630	0.242	0.474	0.362	0.221	0.363	1.733	4195.	95	
	215	350	3250	2500	0.681	0.262	0.464	0.357	0.189	0.311	1.664	3946.	95	
	215	400	3550	2690	0.728	0.280	0.456	0.352	0.166	0.272	1.515	3742.	100	
	215	500	4070	3000	0.814	0.312	0.443	0.345	0.134	0.219	1.420	3423.	100	
	215	600	4590	3300	0.893	0.345	0.431	0.338	0.112	0.183	1.351	3169.	105	
	215	750	5400	3790	0.998	0.385	0.417	0.329	0.091	0.147	1.194	2889.	105	
	215	1000	6640	4490	1.152	0.445	0.400	0.318	0.070	0.111	1.039	2558.	110	
	215	1250	7890	5210	1.289	0.499	0.386	0.308	0.058	0.091	0.918	2321.	115	
	215	1500	9050	5830	1.412	0.546	0.375	0.301	0.050	0.077	0.863	2144.	115	
	215	1750	10170	6410	1.526	0.592	0.365	0.293	0.044	0.067	0.779	2002.	120	
	215	2000	11200	6910	1.632	0.633	0.357	0.288	0.040	0.060	0.744	1886.	120	
	22000 (grounded)	255	2	1740	1590	0.292	0.106	0.574	0.392	0.993	1.637	2.339	8147.	90
255		1	1860	1680	0.332	0.126	0.553	0.387	0.786	1.293	2.245	7504.	90	
255		1/0	1990	1760	0.373	0.141	0.539	0.382	0.621	1.030	2.157	6948.	90	
240		2/0	2180	1890	0.418	0.159	0.525	0.380	0.494	0.816	2.116	6155.	90	
240		3/0	2380	2020	0.470	0.178	0.511	0.374	0.392	0.644	2.020	5674.	90	
240		4/0	2660	2210	0.528	0.200	0.497	0.367	0.311	0.513	1.807	5214.	95	
240		250	2870	2330	0.575	0.221	0.485	0.362	0.264	0.435	1.733	4894.	95	
240		300	3190	2530	0.630	0.242	0.474	0.357	0.221	0.363	1.664	4567.	95	
240		350	3480	2730	0.681	0.262	0.464	0.352	0.189	0.311	1.515	4301.	100	
240		400	3790	2930	0.728	0.280	0.456	0.347	0.166	0.272	1.460	4083.	100	
240		500	4320	3250	0.814	0.312	0.443	0.340	0.134	0.219	1.379	3741.	100	
240		600	4850	3560	0.893	0.345	0.431	0.334	0.112	0.183	1.241	3468.	105	
240		750	5620	4010	0.998	0.385	0.417	0.325	0.091	0.147	1.158	3166.	105	
240		1000	6830	4680	1.152	0.445	0.400	0.314	0.070	0.111	1.010	2808.	110	
240		1250	8060	5370	1.289	0.499	0.386	0.305	0.058	0.091	0.894	2552.	115	
240		1500	9220	6000	1.412	0.546	0.375	0.297	0.050	0.077	0.805	2359.	120	
240		1750	10450	6670	1.526	0.592	0.365	0.290	0.044	0.067	0.761	2205.	120	
240		2000	11600	7280	1.632	0.633	0.357	0.284	0.040	0.060	0.694	2079.	125	
23000 (ungrounded)		310	2	1970	1830	0.292	0.106	0.574	0.378	0.993	1.637	2.096	9183.	90
		310	1	2120	1940	0.332	0.126	0.553	0.374	0.786	1.293	2.020	8494.	90
	310	1/0	2300	2070	0.373	0.141	0.539	0.369	0.621	1.030	1.839	7895.	95	
	310	2/0	2520	2230	0.418	0.159	0.525	0.364	0.494	0.816	1.762	7322.	95	
	310	3/0	2760	2400	0.470	0.178	0.511	0.359	0.392	0.644	1.691	6783.	95	
	310	4/0	3070	2620	0.528	0.200	0.497	0.353	0.311	0.513	1.527	6262.	100	
	310	250	3330	2790	0.575	0.221	0.485	0.348	0.264	0.435	1.471	5898.	100	
	310	300	3630	2990	0.630	0.242	0.474	0.344	0.221	0.363	1.418	5525.	100	
	310	350	3940	3190	0.681	0.262	0.464	0.340	0.189	0.311	1.370	5219.	100	
	310	400	4230	3370	0.728	0.280	0.456	0.335	0.166	0.272	1.257	4967.	105	
	310	500	4760	3685	0.814	0.312	0.443	0.329	0.134	0.219	1.194	4570.	105	
	310	600	5260	3970	0.893	0.345	0.431	0.323	0.112	0.183	1.137	4251.	105	
	310	750	6080	4470	0.998	0.385	0.417	0.315	0.091	0.147	1.016	3896.	110	
	310	1000	7360	5210	1.152	0.445	0.400	0.305	0.070	0.111	0.894	3472.	115	
	310	1250	8700	6020	1.289	0.499	0.386	0.296	0.058	0.091	0.797	3166.	120	
	310	1500	9930	6710	1.412	0.546	0.375	0.289	0.050	0.077	0.754	2935.	120	
	310	1750	11200	7440	1.526	0.592	0.365	0.283	0.044	0.067	0.685	2749.	125	
	310	2000	12300	8020	1.632	0.633	0.357	0.277	0.040	0.060	0.628	2596.	130	

Table 7 concluded on next page

Table 7—60-Cycle Characteristics of Single-Conductor Concentric-Strand Paper-Insulated Cables (Concluded)

Voltage Class	Insulation Thickness—Mils	Conductor Size, AWG (B & S) or Thousand Circular Mils	Weight Per 1000 Ft. Copper Conductor	Weight Per 1000 Ft. Aluminum Conductor	Diameter of Conductor—Inches	GMR of One Conductor—Inches	Z_n		r_n		r_n		Shunt Capacitive Reactance—Ohms Per Phase Per Mile	Lead Sheath Thickness—Mils
							Reactance at 12 Inches—Ohms Per Phase Per Mile	Reactance of Sheath—Ohms Per Phase Per Mile	Reactance of Copper Conductor—Ohms Per Phase Per Mile	Reactance of Aluminum Conductor—Ohms Per Phase Per Mile	Reactance of Sheath—Ohms Per Phase Per Mile at 50°C.			
35000 (grounded)	345	2/0	2690	2400	0.418	0.159	0.525	0.357	0.494	0.816	1.664	7848.	95	
	345	3/0	2910	2550	0.470	0.178	0.511	0.352	0.392	0.644	1.515	7285.	100	
	345	4/0	3190	2740	0.528	0.200	0.497	0.346	0.311	0.513	1.449	6740.	100	
	345	250	3430	2890	0.575	0.221	0.485	0.342	0.264	0.435	1.399	6357.	100	
	345	300	3770	3130	0.630	0.242	0.474	0.338	0.221	0.363	1.351	5964.	100	
	345	350	4100	3350	0.681	0.262	0.464	0.334	0.189	0.311	1.241	5642.	105	
	345	400	4430	3570	0.728	0.280	0.456	0.330	0.166	0.272	1.202	5376.	105	
	345	500	5020	3950	0.814	0.312	0.443	0.324	0.134	0.219	1.144	4955.	105	
	345	600	5610	4320	0.893	0.345	0.431	0.318	0.112	0.183	1.039	4616.	110	
	345	750	6460	4850	0.998	0.385	0.417	0.310	0.091	0.147	0.978	4238.	110	
	345	1000	7700	5550	1.152	0.445	0.400	0.301	0.070	0.111	0.863	3784.	115	
	345	1250	8950	6260	1.289	0.499	0.386	0.292	0.058	0.091	0.772	3457.	120	
	345	1500	10150	6930	1.412	0.546	0.375	0.285	0.050	0.077	0.697	3208.	125	
	345	1750	11450	7690	1.526	0.592	0.365	0.279	0.044	0.067	0.665	3008.	125	
	345	2000	12600	8290	1.632	0.633	0.357	0.273	0.040	0.060	0.611	2843.	130	
	35000 (ungrounded)	455	2/0	3490	3200	0.418	0.159	0.525	0.337	0.494	0.816	1.274	9307.	105
		455	3/0	3710	3350	0.470	0.178	0.511	0.333	0.392	0.644	1.233	8685.	105
		455	4/0	3990	3540	0.528	0.200	0.497	0.328	0.311	0.513	1.187	8078.	105
455		250	4250	3710	0.575	0.221	0.485	0.324	0.264	0.435	1.151	7650.	105	
455		300	4580	3940	0.630	0.242	0.474	0.320	0.221	0.363	1.063	7207.	110	
455		350	4910	4160	0.681	0.262	0.464	0.317	0.189	0.311	1.033	6842.	110	
455		400	5250	4390	0.728	0.280	0.456	0.314	0.166	0.272	1.005	6539.	110	
455		500	5860	4790	0.814	0.312	0.443	0.308	0.134	0.219	0.918	6056.	115	
455		600	6470	5180	0.893	0.345	0.431	0.303	0.112	0.183	0.881	5665.	115	
455		750	7360	5750	0.998	0.385	0.417	0.296	0.091	0.147	0.797	5225.	120	
455		1000	8660	6510	1.152	0.445	0.400	0.288	0.070	0.111	0.744	4694.	120	
455		1250	9940	7260	1.289	0.499	0.386	0.280	0.058	0.091	0.668	4307.	125	
455		1500	11200	7980	1.412	0.546	0.375	0.273	0.050	0.077	0.611	4011.	130	
455		1750	12450	8690	1.526	0.592	0.365	0.268	0.044	0.067	0.560	3771.	135	
455		2000	13700	9420	1.632	0.633	0.357	0.263	0.040	0.060	0.538	3573.	135	
46000 (grounded)		445	4/0	3940	3490	0.528	0.200	0.497	0.330	0.311	0.513	1.202	7966.	105
		445	250	4220	3680	0.575	0.221	0.485	0.326	0.264	0.435	1.165	7541.	105
		445	300	4550	3910	0.630	0.242	0.474	0.322	0.221	0.363	1.076	7102.	110
	445	350	4830	4080	0.681	0.262	0.464	0.318	0.189	0.311	1.045	6740.	110	
	445	400	5220	4360	0.728	0.280	0.456	0.315	0.166	0.272	1.016	6440.	110	
	445	500	5830	4760	0.814	0.312	0.443	0.309	0.134	0.219	0.928	5962.	115	
	445	600	6400	5110	0.893	0.345	0.431	0.304	0.112	0.183	0.890	5575.	115	
	445	750	7310	5700	0.998	0.385	0.417	0.297	0.091	0.147	0.805	5140.	120	
	445	1000	8660	6510	1.152	0.445	0.400	0.289	0.070	0.111	0.751	4616.	120	
	445	1250	9870	7180	1.289	0.499	0.386	0.281	0.058	0.091	0.677	4233.	125	
	445	1500	11000	7780	1.412	0.546	0.375	0.274	0.050	0.077	0.615	3941.	130	
	445	1750	12250	8490	1.526	0.592	0.365	0.269	0.044	0.067	0.587	3705.	130	
	445	2000	13650	9330	1.632	0.633	0.357	0.263	0.040	0.060	0.542	3509.	135	
	69000 (grounded)	650	500	7660	6590	0.814	0.312	0.443	0.284	0.134	0.219	0.694	7701.	125
650		600	8250	6960	0.893	0.345	0.431	0.280	0.112	0.183	0.671	7244.	125	
650		750	9220	7610	0.998	0.385	0.417	0.274	0.091	0.147	0.615	6725.	130	
650		1000	10650	8500	1.152	0.445	0.400	0.267	0.070	0.111	0.556	6091.	135	
650		1250	12100	9420	1.289	0.499	0.386	0.260	0.058	0.091	0.528	5623.	135	
650		1500	13400	10150	1.412	0.546	0.375	0.255	0.050	0.077	0.488	5263.	140	
650		1750	14700	10950	1.526	0.592	0.365	0.250	0.044	0.067	0.451	4969.	145	
650		2000	15950	11650	1.632	0.633	0.357	0.246	0.040	0.060	0.436	4724.	145	

Table 8—60-Cycle Characteristics of Self-Supporting Aerial Cable Rubber-Insulated, Neoprene-Jacketed

Voltage Class	Conductor Size	Stranding	Insulation Thickness	Shielding	Jacket Thickness	Diameter	Messenger Used with Copper Conductors	Wt. Per 1000 Ft. Messenger and Copper	Messenger Used with Aluminum Conductors	Wt. Per 1000 Ft. Messenger and Aluminum	POSITIVE SEQUENCE 60~ AC OHMS/MI.				ZERO SEQUENCE(3) 60~ AC OHMS/MI.				
											Resistance (1)		Reactance		Resistance (1)		Reactance		
											Copper	Aluminum	Series Inductive	Shunt Capacitive(2)	Copper	Aluminum	Copper	Aluminum	Shunt Capacitive(2)
3-kv Ungrounded Neutral	6	7	10/64	No	1/4	0.59	3/8" 30% CCS	1020	3/8" 30% CCS	854	2.52	4.13	0.258	3.592	5.082	3.712	3.712
	4	7	10/64	No	1/4	0.67	3/8" 30% CCS	1230	3/8" 30% CCS	956	1.58	2.58	0.246	2.632	3.572	3.662	3.662
	2	7	10/64	No	1/4	0.73	3/8" 30% CCS	1530	3/8" 30% CCS	1100	1.00	1.64	0.229	2.025	2.605	3.615	3.615
	1	19	10/64	No	1/4	0.77	3/8" 30% CCS	1780	3/8" 30% CCS	1250	0.791	1.29	0.211	1.815	2.275	3.582	3.582
	1/0	19	10/64	No	1/4	0.81	3/8" 30% CCS	2070	3/8" 30% CCS	1390	0.635	1.03	0.207	1.644	2.015	3.555	3.555
	2/0	19	10/64	No	1/4	0.85	3/8" 30% CCS	2510	3/8" 30% CCS	1530	0.501	0.816	0.200	1.622	1.803	3.162	3.528
	3/0	19	10/64	No	1/4	0.91	3/8" 30% CCS	2890	3/8" 30% CCS	1690	0.402	0.644	0.194	1.517	1.637	3.135	3.499
	4/0	19	10/64	No	1/4	0.99	3/8" 30% CCS	3570	3/8" 30% CCS	1900	0.318	0.518	0.191	1.401	1.508	2.665	3.459
	250	37	11/64	No	1/4	1.08	1/2" 30% CCS	4080	3/8" 30% CCS	2160	0.269	0.437	0.189	1.351	1.430	2.035	3.429
	300	37	11/64	No	1/4	1.13	1/2" 30% CCS	4620	3/8" 30% CCS	2500	0.228	0.366	0.184	1.308	1.465	2.612	3.042
	350	37	11/64	No	1/4	1.18	1/2" 30% CCS	5290	3/8" 30% CCS	2780	0.197	0.316	0.180	1.277	1.415	2.591	3.021
	400	37	11/64	No	1/4	1.23	1/2" 30% CCS	5800	3/8" 30% CCS	3040	0.172	0.276	0.176	1.252	1.377	2.576	3.006
500	37	11/64	No	1/4	1.32	1/2" 30% CCS	6860	1/2" 30% CCS	3650	0.141	0.223	0.172	1.219	1.290	2.543	2.543	
6-kv Ungrounded Neutral	6	7	10/64	Yes	1/4	0.74	3/8" 30% CCS	1310	3/8" 30% CCS	1140	2.52	4.13	0.292	4970
	4	7	10/64	Yes	1/4	0.79	3/8" 30% CCS	1540	3/8" 30% CCS	1270	1.58	2.58	0.272	4320
	2	7	10/64	Yes	1/4	0.88	3/8" 30% CCS	1950	3/8" 30% CCS	1520	1.00	1.64	0.257	3630
	1	19	10/64	Yes	1/4	0.92	3/8" 30% CCS	2180	3/8" 30% CCS	1640	0.791	1.29	0.241	3330
	1/0	19	10/64	Yes	1/4	0.96	3/8" 30% CCS	2450	3/8" 30% CCS	1770	0.655	1.03	0.233	3080
	2/0	19	10/64	Yes	1/4	1.00	3/8" 30% CCS	2910	3/8" 30% CCS	1930	0.501	0.816	0.223	2830
	3/0	19	10/64	Yes	1/4	1.06	3/8" 30% CCS	3320	3/8" 30% CCS	2120	0.402	0.644	0.215	2580
	4/0	19	10/64	Yes	1/4	1.11	3/8" 30% CCS	4030	3/8" 30% CCS	2350	0.318	0.518	0.207	2380
	250	37	11/64	Yes	1/4	1.20	1/2" 30% CCS	4570	3/8" 30% CCS	2770	0.269	0.437	0.206	2380
	300	37	11/64	Yes	1/4	1.29	1/2" 30% CCS	5260	3/8" 30% CCS	3140	0.228	0.366	0.203	2280
	350	37	11/64	Yes	1/4	1.34	1/2" 30% CCS	5840	3/8" 30% CCS	3380	0.197	0.316	0.199	2090
	400	37	11/64	Yes	1/4	1.39	1/2" 30% CCS	6380	3/8" 30% CCS	3610	0.172	0.276	0.194	1890
500	37	11/64	Yes	1/4	1.47	1/2" 30% CCS	7470	1/2" 30% CCS	4240	0.141	0.223	0.187	1740	
15-kv Grounded Neutral	6	19	10/64	Yes	1/4	1.05	3/8" 30% CCS	2090	3/8" 30% CCS	1920	2.52	4.13	0.326	7150	3.846	5.346	3.396	3.396	7150
	4	19	10/64	Yes	1/4	1.10	3/8" 30% CCS	2350	3/8" 30% CCS	2080	1.58	2.58	0.302	6260	2.901	3.831	3.364	3.364	6260
	2	19	10/64	Yes	1/4	1.16	3/8" 30% CCS	2860	3/8" 30% CCS	2430	1.00	1.64	0.279	5460	2.459	3.039	2.851	2.851	5460
	1	19	10/64	Yes	1/4	1.20	3/8" 30% CCS	3120	3/8" 30% CCS	2580	0.791	1.29	0.268	5110	2.238	2.701	2.837	2.837	5110
	1/0	19	10/64	Yes	1/4	1.27	3/8" 30% CCS	3560	3/8" 30% CCS	2880	0.655	1.03	0.260	4720	2.052	2.426	2.825	2.825	4720
	2/0	19	10/64	Yes	1/4	1.32	3/8" 30% CCS	4120	3/8" 30% CCS	3070	0.501	0.816	0.249	4370	1.896	2.214	2.251	2.801	4370
	3/0	19	10/64	Yes	1/4	1.37	3/8" 30% CCS	4580	3/8" 30% CCS	3510	0.402	0.644	0.241	4120	1.782	2.008	2.240	2.240	4120
	4/0	19	10/64	Yes	1/4	1.43	3/8" 30% CCS	5150	3/8" 30% CCS	3790	0.318	0.518	0.231	3770	1.681	1.864	2.235	2.235	3770
	250	37	10/64	Yes	1/4	1.47	1/2" 30% CCS	5590	3/8" 30% CCS	3980	0.269	0.437	0.223	3570	1.630	1.782	2.227	2.227	3570
	300	37	10/64	Yes	1/4	1.53	1/2" 30% CCS	6260	3/8" 30% CCS	4330	0.223	0.366	0.217	3330	1.577	1.701	2.226	2.226	3330
	350	37	10/64	Yes	1/4	1.59	1/2" 30% CCS	6870	3/8" 30% CCS	4600	0.197	0.316	0.212	3130	1.536	1.640	2.226	2.226	3130
	400	37	10/64	Yes	1/4	1.63	1/2" 30% CCS	7450	3/8" 30% CCS	4860	0.172	0.276	0.208	2980	1.500	1.592	2.216	2.216	2980
500	37	10/64	Yes	1/4	1.75	1/2" 30% CCS	8970	1/2" 30% CCS	5560	0.141	0.223	0.204	2830	1.454	1.524	2.198	2.198	2830	

(1) AC resistance based on 65°C with allowance for stranding, skin effect and proximity effect.
 (2) Dielectric constant assumed 6.0.

(3) Zero-sequence impedance based on return current both in the messenger and in 100 meter-ohm earth.

Table 9—60-Cycle Characteristics of Rubber-Insulated Neoprene-Jacketed Cables in Ducts

Voltage Class	Conductor Size	Stranding	Insulation Thickness	Shielding	Jacket Thickness	Diameter (Single Cable)	Duct Size(4)	COPPER CONDUCTOR				ALUMINUM CONDUCTOR				Shunt Capacitive(2) Reactance—Ohms Per Mile—Copper or Aluminum		
								Weight Per 1000 Feet	Positive Sequence		Zero (3) Sequence		Weight Per 1000 Feet	Positive Sequence			Zero (3) Sequence	
									Resistance(1) Ohms Per Mi.	Reactance Ohms Per Mi.	Resistance(1) Ohms Per Mi.	Reactance Ohms Per Mi.		Resistance(1) Ohms Per Mi.	Reactance Ohms Per Mi.		Resistance(1) Ohms Per Mi.	Reactance Ohms Per Mi.
5-kv Unshielded Cable Typical Circuit 2400 Volts	6	7	10 ₃ / ₄	No	3/4	0.59	4"	212	2.52	0.458	2.856	3.856	156	4.13	0.458	4.35	3.856	
	4	7	10 ₃ / ₄	No	3/4	0.67	4"	297	1.58	0.429	1.906	3.836	207	2.58	0.429	2.84	3.836	
	2	7	10 ₃ / ₄	No	3/4	0.73	4"	395	1.00	0.398	1.306	3.811	252	1.64	0.398	1.89	3.811	
	1	19	10 ₃ / ₄	No	3/4	0.77	4"	462	0.791	0.375	1.096	3.794	283	1.29	0.375	1.56	3.794	
	1/0	19	10 ₃ / ₄	No	3/4	0.81	4"	544	0.655	0.361	0.925	3.783	317	1.03	0.361	1.30	3.783	
	2/0	19	10 ₃ / ₄	No	3/4	0.85	4"	645	0.501	0.344	0.705	3.772	359	0.816	0.344	1.08	3.772	
	3/0	19	10 ₃ / ₄	No	3/4	0.81	4"	772	0.402	0.330	0.685	3.764	412	0.644	0.330	0.919	3.764	
	4/0	19	10 ₃ / ₄	No	3/4	0.99	4"	958	0.318	0.311	0.608	3.754	504	0.518	0.311	0.790	3.754	
	250	37	11 ₃ / ₄	No	3/4	1.08	4"	1130	0.269	0.295	0.558	3.750	589	0.437	0.295	0.713	3.750	
	300	37	11 ₃ / ₄	No	3/4	1.13	4"	1300	0.228	0.283	0.512	3.744	660	0.366	0.283	0.642	3.744	
	350	37	11 ₃ / ₄	No	3/4	1.18	4"	1480	0.197	0.271	0.481	3.738	729	0.316	0.271	0.591	3.738	
	400	37	11 ₃ / ₄	No	3/4	1.23	4"	1650	0.172	0.261	0.457	3.734	794	0.276	0.261	0.553	3.734	
	500	37	11 ₃ / ₄	No	3/4	1.32	4"	2000	0.141	0.242	0.422	3.730	924	0.223	0.242	0.500	3.730	
5-kv Shielded Cable Typical Circuit 4160 Volts	6	7	10 ₃ / ₄	Yes	3/4	0.74	4"	344	2.52	0.454	2.856	3.863	288	4.13	0.454	4.35	3.863	4970
	4	7	10 ₃ / ₄	Yes	3/4	0.79	4"	420	1.58	0.424	1.906	3.839	330	2.58	0.424	2.84	3.839	4320
	2	7	10 ₃ / ₄	Yes	3/4	0.88	4"	557	1.00	0.393	1.306	3.817	414	1.64	0.393	1.89	3.817	3630
	1	19	10 ₃ / ₄	Yes	3/4	0.92	4"	632	0.791	0.370	1.096	3.807	453	1.29	0.370	1.56	3.807	3330
	1/0	19	10 ₃ / ₄	Yes	3/4	0.96	4"	721	0.655	0.355	0.925	3.795	494	1.03	0.355	1.30	3.795	3080
	2/0	19	10 ₃ / ₄	Yes	3/4	1.00	4"	833	0.501	0.339	0.793	3.784	547	0.816	0.339	1.08	3.784	2830
	3/0	19	10 ₃ / ₄	Yes	3/4	1.06	4"	970	0.402	0.322	0.685	3.775	610	0.644	0.322	0.919	3.775	2580
	4/0	19	10 ₃ / ₄	Yes	3/4	1.11	4"	1140	0.318	0.305	0.608	3.766	685	0.518	0.305	0.790	3.766	2380
	250	37	11 ₃ / ₄	Yes	3/4	1.20	4"	1320	0.269	0.291	0.558	3.761	783	0.437	0.291	0.713	3.761	2380
	300	37	11 ₃ / ₄	Yes	3/4	1.29	4"	1550	0.228	0.276	0.512	3.758	906	0.366	0.276	0.642	3.758	2280
	350	37	11 ₃ / ₄	Yes	3/4	1.34	4"	1740	0.197	0.264	0.481	3.754	985	0.316	0.264	0.591	3.754	2090
	400	37	11 ₃ / ₄	Yes	3/4	1.39	4"	1920	0.172	0.253	0.457	3.750	1060	0.276	0.253	0.553	3.750	1890
	500	37	11 ₃ / ₄	Yes	3/4	1.47	4"	2280	0.141	0.236	0.422	3.743	1210	0.223	0.236	0.500	3.743	1740
8-kv Shielded Cable Typical Circuit 4600 Volts	6	19	13 ₃ / ₄	Yes	3/4	0.80	4"	385	2.52	0.445	2.856	3.867	329	4.13	0.445	4.35	3.867	5570
	4	19	13 ₃ / ₄	Yes	3/4	0.88	4"	490	1.58	0.414	1.906	3.845	400	2.58	0.414	2.84	3.845	4780
	2	19	13 ₃ / ₄	Yes	3/4	0.94	4"	602	1.00	0.384	1.306	3.821	459	1.64	0.384	1.89	3.821	4130
	1	19	13 ₃ / ₄	Yes	3/4	0.98	4"	684	0.791	0.368	1.096	3.811	505	1.29	0.368	1.56	3.811	3780
	1/0	19	13 ₃ / ₄	Yes	3/4	1.03	4"	774	0.655	0.352	0.925	3.801	547	1.03	0.352	1.30	3.801	3480
	2/0	19	13 ₃ / ₄	Yes	3/4	1.08	4"	888	0.501	0.335	0.793	3.790	602	0.816	0.335	1.08	3.790	3230
	3/0	19	13 ₃ / ₄	Yes	3/4	1.12	4"	1030	0.402	0.320	0.685	3.781	667	0.644	0.320	0.919	3.781	2930
	4/0	19	13 ₃ / ₄	Yes	3/4	1.18	4"	1200	0.318	0.303	0.608	3.770	744	0.518	0.303	0.790	3.770	2740
	250	37	13 ₃ / ₄	Yes	3/4	1.26	4"	1390	0.269	0.288	0.558	3.767	855	0.437	0.288	0.713	3.767	2540
	300	37	13 ₃ / ₄	Yes	3/4	1.32	4"	1580	0.228	0.274	0.512	3.762	936	0.366	0.274	0.642	3.762	2340
	350	37	13 ₃ / ₄	Yes	3/4	1.37	4"	1770	0.197	0.262	0.481	3.756	1020	0.316	0.262	0.591	3.756	2190
	400	37	13 ₃ / ₄	Yes	3/4	1.41	4"	1960	0.172	0.252	0.457	3.752	1100	0.276	0.252	0.553	3.752	2090
	500	37	13 ₃ / ₄	Yes	3/4	1.50	5"	2320	0.141	0.276	0.422	3.665	1250	0.223	0.276	0.500	3.665	1890
15-kv Shielded Cable Typical Circuit 13,800 Volts	6	19	15 ₃ / ₄	Yes	3/4	1.05	4"	597	2.52	0.435	2.856	3.887	541	4.13	0.435	4.35	3.887	7150
	4	19	15 ₃ / ₄	Yes	3/4	1.10	4"	685	1.58	0.405	1.906	3.863	595	2.58	0.405	2.84	3.863	6260
	2	19	15 ₃ / ₄	Yes	3/4	1.16	4"	810	1.00	0.375	1.306	3.839	667	1.64	0.375	1.89	3.839	5460
	1	19	15 ₃ / ₄	Yes	3/4	1.20	4"	894	0.791	0.359	1.096	3.829	715	1.29	0.359	1.56	3.829	5110
	1/0	19	15 ₃ / ₄	Yes	3/4	1.27	4"	1040	0.655	0.342	0.925	3.821	813	1.03	0.342	1.30	3.821	4720
	2/0	19	15 ₃ / ₄	Yes	3/4	1.32	4"	1160	0.501	0.325	0.793	3.810	878	0.816	0.325	1.08	3.810	4370
	3/0	19	15 ₃ / ₄	Yes	3/4	1.37	4"	1310	0.402	0.309	0.685	3.803	954	0.644	0.309	0.919	3.803	4120
	4/0	19	15 ₃ / ₄	Yes	3/4	1.43	4"	1500	0.318	0.292	0.608	3.792	1050	0.518	0.292	0.790	3.792	3770
	250	37	15 ₃ / ₄	Yes	3/4	1.47	4"	1640	0.269	0.279	0.558	3.785	1100	0.437	0.279	0.713	3.785	3570
	300	37	15 ₃ / ₄	Yes	3/4	1.53	5"	1860	0.228	0.306	0.512	3.698	1220	0.366	0.306	0.642	3.698	3330
	350	37	15 ₃ / ₄	Yes	3/4	1.59	5"	2060	0.197	0.294	0.481	3.692	1310	0.316	0.294	0.591	3.692	3130
	400	37	15 ₃ / ₄	Yes	3/4	1.63	5"	2250	0.172	0.284	0.457	3.688	1390	0.276	0.284	0.553	3.688	2980
	500	37	15 ₃ / ₄	Yes	3/4	1.75	5"	2690	0.141	0.267	0.422	3.683	1610	0.223	0.267	0.500	3.683	2830

(1) A-C resistance based on 65°C. with allowance for stranding, skin effect and proximity effect.
 (2) Dielectric constant assumed 6.0.

(3) Zero-sequence impedance based on all return current in 100 meter-ohm earth.
 (4) Duct size assumed so that three cables fill not more than 40% of duct cross section. Random spacing assumed within duct.

Table 10—Inductive Reactance Spacing Factor (x_d) Ohms per Conductor per Mile

25 CYCLES

		SEPARATION											
		INCHES											
Feet		0	1	2	3	4	5	6	7	8	9	10	11
0	0	-0.1256	-0.0906	-0.0701	-0.0555	-0.0443	-0.0350	-0.0273	-0.0205	-0.0145	-0.0092	-0.0044	0.0329
1	0	0.0049	0.0078	0.0113	0.0145	0.0176	0.0205	0.0232	0.0258	0.0283	0.0306	0.0329	0.0541
2	0.0350	0.0371	0.0391	0.0410	0.0428	0.0446	0.0463	0.0480	0.0496	0.0511	0.0527	0.0541	0.0690
3	0.0555	0.0569	0.0583	0.0596	0.0609	0.0621	0.0633	0.0645	0.0657	0.0668	0.0679	0.0689	0.0805
4	0.0701	0.0711	0.0722	0.0732	0.0741	0.0751	0.0760	0.0770	0.0779	0.0788	0.0797	0.0805	0.0899
5	0.0814	0.0822	0.0830	0.0838	0.0846	0.0854	0.0862	0.0869	0.0877	0.0884	0.0892	0.0899	0.0978
6	0.0906	0.0913	0.0920	0.0927	0.0933	0.0940	0.0946	0.0953	0.0959	0.0965	0.0972	0.0978	0.1046
7	0.0984	0.0990	0.0996	0.1002	0.1007	0.1013	0.1019	0.1024	0.1030	0.1035	0.1041	0.1046	
8	0.1051												
9	0.1111												

x_d at 25 cycles
 $x_d = 0.1164 \log_{10} d$
 $d = \text{separation, feet.}$
FUNDAMENTAL EQUATIONS
 $x_1 = x_2 = r_a + j(x_a + x_d)$
 $x_0 = r_a + r_s + j(x_a + x_s - 2x_d)$

50 CYCLES

		SEPARATION											
		Inches											
Feet		0	1	2	3	4	5	6	7	8	9	10	11
10	0.1164												
11	0.1212												
12	0.1256												
13	0.1297												
14	0.1334												
15	0.1369												
16	0.1402												
17	0.1432												
18	0.1461	0	-0.2513	-0.1812	-0.1402	-0.1111	-0.0885	-0.0701	-0.0545	-0.0410	-0.0291	-0.0184	-0.0088
19	0.1489	1	0	0.0081	0.0156	0.0226	0.0291	0.0352	0.0410	0.0465	0.0517	0.0566	0.0613
20	0.1515	2	0.0701	0.0742	0.0782	0.0820	0.0857	0.0892	0.0927	0.0960	0.0992	0.1023	0.1053
21	0.1539	3	0.1111	0.1139	0.1166	0.1192	0.1217	0.1242	0.1267	0.1291	0.1314	0.1337	0.1359
22	0.1563	4	0.1402	0.1423	0.1443	0.1463	0.1483	0.1502	0.1521	0.1539	0.1558	0.1576	0.1593
23	0.1585	5	0.1627	0.1644	0.1661	0.1677	0.1693	0.1708	0.1724	0.1739	0.1754	0.1769	0.1783
24	0.1607	6	0.1812	0.1826	0.1839	0.1853	0.1866	0.1880	0.1893	0.1906	0.1918	0.1931	0.1943
25	0.1627	7	0.1968	0.1980	0.1991	0.2003	0.2015	0.2026	0.2037	0.2049	0.2060	0.2071	0.2081
26	0.1647	8	0.2103										
27	0.1666	9	0.2222										
28	0.1685	10	0.2328										
29	0.1702	11	0.2425										
30	0.1720	12	0.2513										
31	0.1736	13	0.2594										
32	0.1752	14	0.2669										
33	0.1768	15	0.2738										
34	0.1783	16	0.2804										
35	0.1798	17	0.2865										
36	0.1812	18	0.2923	0	-0.3015	-0.2174	-0.1682	-0.1333	-0.1062	-0.0841	-0.0654	-0.0492	-0.0349
37	0.1826	19	0.2977	1	0	0.0097	0.0187	0.0271	0.0349	0.0423	0.0492	0.0558	0.0620
38	0.1839	20	0.3029	2	0.0841	0.0891	0.0938	0.0984	0.1028	0.1071	0.1112	0.1152	0.1190
39	0.1852	21	0.3079	3	0.1333	0.1366	0.1399	0.1430	0.1461	0.1491	0.1520	0.1549	0.1577
40	0.1865	22	0.3128	4	0.1682	0.1707	0.1732	0.1756	0.1779	0.1802	0.1825	0.1847	0.1869
41	0.1878	23	0.3170	5	0.1953	0.1973	0.1993	0.2012	0.2031	0.2050	0.2069	0.2087	0.2105
42	0.1890	24	0.3214	6	0.2174	0.2191	0.2207	0.2224	0.2240	0.2256	0.2271	0.2287	0.2302
43	0.1902	25	0.3255	7	0.2361	0.2376	0.2390	0.2404	0.2418	0.2431	0.2445	0.2458	0.2472
44	0.1913	26	0.3294	8	0.2523								
45	0.1925	27	0.3333	9	0.2666								
46	0.1936	28	0.3369	10	0.2794								
47	0.1947	29	0.3405	11	0.2910								
48	0.1957	30	0.3439	12	0.3015								
49	0.1968	31	0.3472	13	0.3112								
		32	0.3504	14	0.3202								
		33	0.3536	15	0.3286								
		34	0.3566	16	0.3364								
		35	0.3595	17	0.3438								
		36	0.3624	18	0.3507								
		37	0.3651	19	0.3573								
		38	0.3678	20	0.3635								
		39	0.3704	21	0.3694								
		40	0.3730	22	0.3751								
		41	0.3755	23	0.3805								
		42	0.3779	24	0.3856								
		43	0.3803	25	0.3906								
		44	0.3826	26	0.3953								
		45	0.3849	27	0.3999								
		46	0.3871	28	0.4043								
		47	0.3893	29	0.4086								
		48	0.3914	30	0.4127								
		49	0.3935	31	0.4167								
				32	0.4205								
				33	0.4243								
				34	0.4279								
				35	0.4314								
				36	0.4348								
				37	0.4382								
				38	0.4414								
				39	0.4445								
				40	0.4476								
				41	0.4506								
				42	0.4535								
				43	0.4564								
				44	0.4592								
				45	0.4619								
				46	0.4646								
				47	0.4672								
				48	0.4697								
				49	0.4722								

x_d at 50 cycles
 $x_d = 0.2328 \log_{10} d$
 $d = \text{separation, feet.}$

x_d at 60 cycles
 $x_d = 0.2794 \log_{10} d$
 $d = \text{separation, feet.}$

Zero-Sequence Resistance and Inductive Reactance Factors (r_0, x_0)*
 Ohms per Conductor per Mile

	Meter Ohm	FREQUENCY		
		25 Cycles	50 Cycles	60 Cycles
r_0	All	0.1192	0.2383	0.2860
x_0	1	0.921	1.736	2.050
	5	1.043	1.980	2.343
	10	1.095	2.085	2.469
	50	1.217	2.329	2.762
	100†	1.270	2.434	2.888
	500	1.392	2.679	3.181
	1000	1.444	2.784	3.307
	5000	1.566	3.028	3.600
	10 000	1.619	3.133	3.726

*From Formulas:
 $r_0 = 0.004764f$
 $x_0 = 0.006985 / \log_{10} 4 665 600 \frac{p}{f}$
 where f = frequency
 p = Resistivity (meter, ohm)
 †This is an average value which may be used in the absence of definite information.

Table 11—Shunt Capacitive Reactance Spacing Factor (x_d') Megohms per Conductor per Mile

25 CYCLES

		SEPARATION														
		INCHES														
Feet		0	1	2	3	4	5	6	7	8	9	10	11			
0	—	-0.1769	-0.1276	-0.0987	-0.0782	-0.0623	-0.0494	-0.0384	-0.0289	-0.0205	-0.0130	-0.0062				
1	0	0.0057	0.0110	0.0159	0.0205	0.0248	0.0289	0.0327	0.0364	0.0398	0.0432	0.0463				
2	0.0494	0.0523	0.0551	0.0577	0.0603	0.0628	0.0652	0.0676	0.0698	0.0720	0.0742	0.0762				
3	0.0782	0.0802	0.0821	0.0839	0.0857	0.0875	0.0892	0.0909	0.0925	0.0941	0.0957	0.0972				
4	0.0987	0.1002	0.1016	0.1030	0.1044	0.1058	0.1071	0.1084	0.1097	0.1109	0.1122	0.1134				
5	0.1146	0.1158	0.1169	0.1181	0.1192	0.1203	0.1214	0.1225	0.1235	0.1246	0.1256	0.1266				
6	0.1276	0.1286	0.1295	0.1305	0.1314	0.1324	0.1333	0.1342	0.1351	0.1360	0.1368	0.1377				
7	0.1386	0.1394	0.1402	0.1411	0.1419	0.1427	0.1435	0.1443	0.1450	0.1458	0.1466	0.1473				
8	0.1481															
9	0.1505															
10	0.1640															
11	0.1707															
12	0.1769															
13	0.1826															
14	0.1879															
15	0.1928															
16	0.1974															
17	0.2017															
18	0.2058	0	—	-0.0885	-0.0638	-0.0494	-0.0391	-0.0312	-0.0247	-0.0192	-0.0144	-0.0102	0.0065	-0.0031		
19	0.2097	1	0	0.0028	0.0055	0.0079	0.0102	0.0124	0.0144	0.0164	0.0182	0.0199	0.0216	0.0232		
20	0.2133	2	0.0247	0.0261	0.0275	0.0289	0.0302	0.0314	0.0326	0.0338	0.0349	0.0360	0.0371	0.0381		
21	0.2168	3	0.0391	0.0401	0.0410	0.0420	0.0429	0.0437	0.0446	0.0454	0.0463	0.0471	0.0478	0.0486		
22	0.2201	4	0.0494	0.0501	0.0508	0.0515	0.0522	0.0529	0.0535	0.0542	0.0548	0.0555	0.0561	0.0567		
23	0.2233	5	0.0573	0.0579	0.0585	0.0590	0.0596	0.0601	0.0607	0.0612	0.0618	0.0623	0.0628	0.0633		
24	0.2263	6	0.0638	0.0643	0.0648	0.0652	0.0657	0.0662	0.0666	0.0671	0.0675	0.0680	0.0684	0.0689		
25	0.2292	7	0.0693	0.0697	0.0701	0.0705	0.0709	0.0713	0.0717	0.0721	0.0725	0.0729	0.0733	0.0737		
26	0.2320	8	0.0740													
27	0.2347	9	0.0782													
28	0.2373	10	0.0820													
29	0.2398	11	0.0854													
30	0.2422	12	0.0885													
31	0.2445	13	0.0913													
32	0.2468	14	0.0940													
33	0.2490	15	0.0964													
34	0.2511	16	0.0987													
35	0.2532	17	0.1009													
36	0.2552	18	0.1029	0	—	-0.0737	-0.0532	-0.0411	-0.0326	-0.0260	-0.0206	-0.0160	-0.0120	-0.0085	-0.0054	-0.0026
37	0.2571	19	0.1048	1	0	0.0024	0.0046	0.0066	0.0085	0.0103	0.0120	0.0136	0.0152	0.0166	0.0180	0.0193
38	0.2590	20	0.1067	2	0.0206	0.0218	0.0229	0.0241	0.0251	0.0262	0.0272	0.0282	0.0291	0.0300	0.0309	0.0318
39	0.2609	21	0.1084	3	0.0326	0.0334	0.0342	0.0350	0.0357	0.0365	0.0372	0.0379	0.0385	0.0392	0.0399	0.0405
40	0.2627	22	0.1100	4	0.0411	0.0417	0.0423	0.0429	0.0435	0.0441	0.0446	0.0452	0.0457	0.0462	0.0467	0.0473
41	0.2644	23	0.1116	5	0.0478	0.0482	0.0487	0.0492	0.0497	0.0501	0.0506	0.0510	0.0515	0.0519	0.0523	0.0527
42	0.2661	24	0.1131	6	0.0532	0.0536	0.0540	0.0544	0.0548	0.0552	0.0555	0.0559	0.0563	0.0567	0.0570	0.0574
43	0.2678	25	0.1146	7	0.0577	0.0581	0.0584	0.0588	0.0591	0.0594	0.0598	0.0601	0.0604	0.0608	0.0611	0.0614
44	0.2695	26	0.1160	8	0.0617											
45	0.2711	27	0.1173	9	0.0652											
46	0.2726	28	0.1186	10	0.0683											
47	0.2742	29	0.1199	11	0.0711											
48	0.2756	30	0.1211	12	0.0737											
49	0.2771	31	0.1223	13	0.0761											
		32	0.1234	14	0.0783											
		33	0.1245	15	0.0803											
		34	0.1255	16	0.0823											
		35	0.1266	17	0.0841											
		36	0.1276	18	0.0858											
		37	0.1286	19	0.0874											
		38	0.1295	20	0.0889											
		39	0.1304	21	0.0903											
		40	0.1313	22	0.0917											
		41	0.1322	23	0.0930											
		42	0.1331	24	0.0943											
		43	0.1339	25	0.0955											
		44	0.1347	26	0.0967											
		45	0.1355	27	0.0978											
		46	0.1363	28	0.0989											
		47	0.1371	29	0.0999											
		48	0.1378	30	0.1009											
		49	0.1386	31	0.1019											
				32	0.1028											
				33	0.1037											
				34	0.1046											
				35	0.1055											
				36	0.1063											
				37	0.1071											
				38	0.1079											
				39	0.1087											
				40	0.1094											
				41	0.1102											
				42	0.1109											
				43	0.1116											
				44	0.1123											
				45	0.1129											
				46	0.1136											
				47	0.1142											
				48	0.1149											
				49	0.1155											

x_d' at
25 cycles
 $x_d' = .1640 \log_{10} d$
 $d = \text{separation, feet.}$

FUNDAMENTAL EQUATIONS
 $x_1' = x_2' = x_a' + x_d'$
 $x_0' = x_a' + x_b' - 2x_d'$

50 CYCLES

		SEPARATION														
		Inches														
Feet		0	1	2	3	4	5	6	7	8	9	10	11			
18	0.2058	0	—	-0.0885	-0.0638	-0.0494	-0.0391	-0.0312	-0.0247	-0.0192	-0.0144	-0.0102	0.0065	-0.0031		
19	0.2097	1	0	0.0028	0.0055	0.0079	0.0102	0.0124	0.0144	0.0164	0.0182	0.0199	0.0216	0.0232		
20	0.2133	2	0.0247	0.0261	0.0275	0.0289	0.0302	0.0314	0.0326	0.0338	0.0349	0.0360	0.0371	0.0381		
21	0.2168	3	0.0391	0.0401	0.0410	0.0420	0.0429	0.0437	0.0446	0.0454	0.0463	0.0471	0.0478	0.0486		
22	0.2201	4	0.0494	0.0501	0.0508	0.0515	0.0522	0.0529	0.0535	0.0542	0.0548	0.0555	0.0561	0.0567		
23	0.2233	5	0.0573	0.0579	0.0585	0.0590	0.0596	0.0601	0.0607	0.0612	0.0618	0.0623	0.0628	0.0633		
24	0.2263	6	0.0638	0.0643	0.0648	0.0652	0.0657	0.0662	0.0666	0.0671	0.0675	0.0680	0.0684	0.0689		
25	0.2292	7	0.0693	0.0697	0.0701	0.0705	0.0709	0.0713	0.0717	0.0721	0.0725	0.0729	0.0733	0.0737		
26	0.2320	8	0.0740													
27	0.2347	9	0.0782													
28	0.2373	10	0.0820													
29	0.2398	11	0.0854													
30	0.2422	12	0.0885													
31	0.2445	13	0.0913													
32	0.2468	14	0.0940													
33	0.2490	15	0.0964													
34	0.2511	16	0.0987													
35	0.2532	17	0.1009													
36	0.2552	18	0.1029	0	—	-0.0737	-0.0532	-0.0411	-0.0326	-0.0260	-0.0206	-0.0160	-0.0120	-0.0085	-0.0054	-0.0026
37	0.2571	19	0.1048	1	0	0.0024	0.0046	0.0066	0.0085	0.0103	0.01					

TRANSFORMER EQUIVALENT CIRCUITS

The procedure to be followed in calculating the impedance values for a transformer equivalent circuit depends on the form of the original data, and whether the final values are to be expressed in ohms or per cent. Procedure I, below, is convenient for the simpler cases when the original impedances are expressed in per cent on a circuit base and the final values are to be expressed in per cent. Procedure II is generally recommended for the more complicated cases, particularly for the ones involving neutral impedances or series transformers.

Procedure I. The impedances of two- and three-winding transformers are normally given in per cent on a circuit kva base. With the basic data in this form it is convenient to calculate the equivalent-circuit impedance values directly in per cent. The equivalent circuits and equations for calculating the sequence quantities are given in Table 12 for 13 of the more common transformer connections. The following notation is employed in the table:

1. Terminal designations.

Circuit 4—abc terminals.

Circuit 5—a'b'c' terminals.

Circuit 6—a''b''c'' terminals.

2. Impedances.

$Z_{45}\%$ —impedance circuit 4 to circuit 5 in per cent on 3-phase rated kva of circuit 4.

$Z_{46}\%$ —impedance circuit 4 to circuit 6 in per cent on 3-phase rated kva of circuit 4.

$Z_{56}\%$ —impedance circuit 5 to circuit 6 in per cent on 3-phase rated kva of circuit 5.

$Z_1\%$, $Z_0\%$, $Z_{H1}\%$, $Z_{M1}\%$, $Z_{L1}\%$, $Z_{H0}\%$, $Z_{M0}\%$, and $Z_{L0}\%$ are all in per cent on the 3-phase rated kva of circuit 4.

U_4 , U_5 , and U_6 designate the 3-phase kva ratings of circuits 4, 5 and 6, respectively.

The impedances can be converted from one base to another by the relations,

$$Z_{46}\% = \frac{U_4}{U_6} Z_{64}\%$$

$$Z_{56}\% = \frac{U_5}{U_6} Z_{65}\%$$

$$Z_{45}\% = \frac{U_4}{U_5} Z_{54}\%$$

Procedure II. In many cases, particularly the ones involving neutral impedances or series transformers, less confusion results if the equivalent-circuit impedance values are calculated in ohms, rather than in per cent. However, as the basic data are normally in per cent, it is first necessary to convert to ohms using the following relations:

$$Z_{45} = \frac{10Z_{45}\%E_4^2}{U_4}$$

$$Z_{46} = \frac{10Z_{46}\%E_4^2}{U_4}$$

$$Z_{56} = \frac{10Z_{56}\%E_5^2}{U_5}, \text{ where}$$

$Z_{45}\%$, $Z_{46}\%$, $Z_{56}\%$ are as defined in I.

E_4 , E_5 and E_6 = line-to-line voltages, in kv, in circuits 4, 5 and 6, respectively.

U_4 , U_5 and U_6 = 3-phase kva ratings of circuits 4, 5 and 6, respectively.

Z_{45} = impedance between circuits 4 and 5 in ohms on circuit 4 voltage base.

Z_{46} = impedance between circuits 4 and 6 in ohms on circuit 4 voltage base.

Z_{56} = impedance between circuits 5 and 6 in ohms on circuit 5 voltage base.

Table 12—Transformer Equivalent Circuits Used in Procedure I

TWO-CIRCUIT TRANSFORMERS			
DESCRIPTION	DIAGRAM OF CONNECTIONS	POSITIVE-SEQUENCE EQUIVALENT CIRCUIT	ZERO-SEQUENCE EQUIVALENT CIRCUIT
A-1 STAR/STAR SOLIDLY GROUNDED NEUTRALS (NOT FOR 3 PHASE CORE TYPE)		 $Z_1\% = Z_{45}\%$	 $Z_0\% = Z_{45}\%$
A-4 STAR/STAR NEUTRALS CONNECTED BUT UNGROUNDED (NOT FOR 3 PHASE CORE TYPE)		SAME AS A-1	 $Z_0\% = \infty$
A-5 STAR/DELTA SOLIDLY GROUNDED NEUTRAL		 $Z_1\% = Z_{45}\%$	 $Z_0\% = Z_{45}\%$
A-6 DELTA/STAR SOLIDLY GROUNDED NEUTRAL		SAME AS A-5	 $Z_0\% = Z_{45}\%$
A-7 DELTA-DELTA		SAME AS A-1	SAME AS A-4
TWO-CIRCUIT AUTOTRANSFORMERS			
B-1 STAR/STAR SOLIDLY GROUNDED NEUTRAL (NOT FOR 3 PHASE CORE TYPE)		SAME AS A-1	SAME AS A-1
B-3 STAR/STAR UNGROUNDED NEUTRAL (NOT FOR 3 PHASE CORE TYPE)		SAME AS A-1	SAME AS A-4
THREE-CIRCUIT TRANSFORMER			
C-1 STAR/STAR/ STAR SOLIDLY GROUNDED NEUTRALS		 $Z_{M1}\% = \frac{1}{2} \left[Z_{45}\% + Z_{46}\% - \frac{U_4}{U_5} Z_{56}\% \right]$ $Z_{L1}\% = \frac{1}{2} \left[Z_{46}\% + \frac{U_4}{U_5} Z_{56}\% - Z_{45}\% \right]$ $Z_{H1}\% = \frac{1}{2} \left[\frac{U_4}{U_5} Z_{56}\% + Z_{45}\% - Z_{46}\% \right]$	 $Z_{M0}\% = Z_{M1}\%$ $Z_{L0}\% = Z_{L1}\%$ $Z_{H0}\% = Z_{H1}\%$

Concluded on next page

Table 12—Transformer Equivalent Circuits Used in Procedure I (Concluded)

THREE-CIRCUIT TRANSFORMERS (CONT'D.)			
DESCRIPTION	DIAGRAM OF CONNECTIONS	POSITIVE-SEQUENCE EQUIVALENT CIRCUIT	ZERO SEQUENCE EQUIVALENT CIRCUIT
C-3 STAR/STAR/ DELTA SOLIDLY GROUNDED NEUTRALS		$Z_{M1}\% = \frac{1}{2} \left[Z_{45}\% + Z_{46}\% - \frac{U_4}{U_5} Z_{56}\% \right]$ $Z_{L1}\% = \frac{1}{2} \left[Z_{46}\% + \frac{U_4}{U_5} Z_{56}\% - Z_{45}\% \right]$ $Z_{H1}\% = \frac{1}{2} \left[\frac{U_4}{U_5} Z_{56}\% + Z_{45}\% - Z_{46}\% \right]$	$Z_{M0}\% = Z_{M1}\%$ $Z_{L0}\% = Z_{L1}\%$ $Z_{H0}\% = Z_{H1}\%$
C-6 DELTA/STAR/ DELTA SOLIDLY GROUNDED NEUTRAL		$Z_{M1}\% = \frac{1}{2} \left[Z_{45}\% + Z_{46}\% - \frac{U_4}{U_5} Z_{56}\% \right]$ $Z_{L1}\% = \frac{1}{2} \left[Z_{46}\% + \frac{U_4}{U_5} Z_{56}\% - Z_{45}\% \right]$ $Z_{H1}\% = \frac{1}{2} \left[\frac{U_4}{U_5} Z_{56}\% + Z_{45}\% - Z_{46}\% \right]$	$Z_{M0}\% = Z_{M1}\%$ $Z_{L0}\% = Z_{L1}\%$ $Z_{H0}\% = Z_{H1}\%$
C-7 DELTA/DELTA/ DELTA		SAME AS C-1	$Z_{M0}\% = Z_{M1}\%$ $Z_{L0}\% = Z_{L1}\%$ $Z_{H0}\% = Z_{H1}\%$
THREE-CIRCUIT AUTOTRANSFORMERS			
D-1 STAR/STAR/ DELTA SOLIDLY GROUNDED NEUTRAL		$Z_{M1}\% = \frac{1}{2} \left[Z_{45}\% + Z_{46}\% - \frac{U_4}{U_5} Z_{56}\% \right]$ $Z_{L1}\% = \frac{1}{2} \left[Z_{46}\% + \frac{U_4}{U_5} Z_{56}\% - Z_{45}\% \right]$ $Z_{H1}\% = \frac{1}{2} \left[\frac{U_4}{U_5} Z_{56}\% + Z_{45}\% - Z_{46}\% \right]$	$Z_{M0}\% = Z_{M1}\%$ $Z_{L0}\% = Z_{L1}\%$ $Z_{H0}\% = Z_{H1}\%$
D-2 STAR/STAR/ DELTA UNGROUND NEUTRAL		SAME AS D-1	$N' = \frac{E_3}{E_4}$ $Z_0\% = N'(N'-1) \left[\frac{U_4}{U_5} Z_{56}\% - \frac{Z_{46}\%}{N'} + \frac{Z_{45}\%}{N'-1} \right]$

Table 13—Trigonometric Functions

Angle in degrees	Name of function	Value of function for each tenth of a degree									Angle in degrees	Name of function	Value of function for each tenth of a degree										
		0.0	0.1	0.2	0.3	0.4	0.5	0.6	0.7	0.8			0.9	0.0	0.1	0.2	0.3	0.4	0.5	0.6	0.7	0.8	0.9
0	sin	0.0000	0.0017	0.0035	0.0052	0.0070	0.0087	0.0105	0.0122	0.0140	0.0157	25	sin	0.4226	0.4242	0.4258	0.4274	0.4289	0.4305	0.4321	0.4337	0.4352	0.4368
	cos	1.0000	1.0000	1.0000	1.0000	1.0000	1.0000	0.9999	0.9999	0.9999	0.9999		cos	0.9063	0.9056	0.9048	0.9041	0.9033	0.9026	0.9018	0.9011	0.9003	0.8996
	tan	0.0000	0.0017	0.0035	0.0052	0.0070	0.0087	0.0105	0.0122	0.0140	0.0157		tan	0.4663	0.4684	0.4706	0.4727	0.4748	0.4770	0.4791	0.4813	0.4834	0.4856
1	sin	0.0175	0.0192	0.0209	0.0227	0.0244	0.0262	0.0279	0.0297	0.0314	0.0332	26	sin	0.4384	0.4399	0.4415	0.4431	0.4446	0.4462	0.4478	0.4493	0.4509	0.4524
	cos	0.9998	0.9998	0.9998	0.9997	0.9997	0.9997	0.9996	0.9996	0.9995	0.9995		cos	0.8988	0.8980	0.8973	0.8965	0.8957	0.8949	0.8942	0.8934	0.8926	0.8918
	tan	0.0175	0.0192	0.0209	0.0227	0.0244	0.0262	0.0279	0.0297	0.0314	0.0332		tan	0.4877	0.4899	0.4921	0.4942	0.4964	0.4986	0.5008	0.5029	0.5051	0.5073
2	sin	0.0349	0.0366	0.0384	0.0401	0.0419	0.0436	0.0454	0.0471	0.0488	0.0506	27	sin	0.4540	0.4555	0.4571	0.4586	0.4602	0.4617	0.4633	0.4648	0.4664	0.4679
	cos	0.9994	0.9993	0.9993	0.9992	0.9991	0.9990	0.9990	0.9989	0.9988	0.9987		cos	0.8910	0.8902	0.8894	0.8886	0.8878	0.8870	0.8862	0.8854	0.8846	0.8838
	tan	0.0349	0.0367	0.0384	0.0402	0.0419	0.0437	0.0454	0.0472	0.0489	0.0507		tan	0.5095	0.5117	0.5139	0.5161	0.5184	0.5206	0.5228	0.5250	0.5272	0.5295
3	sin	0.0523	0.0541	0.0558	0.0576	0.0593	0.0610	0.0628	0.0645	0.0663	0.0680	28	sin	0.4695	0.4710	0.4726	0.4741	0.4756	0.4772	0.4787	0.4802	0.4818	0.4833
	cos	0.9980	0.9985	0.9984	0.9983	0.9982	0.9981	0.9980	0.9979	0.9978	0.9977		cos	0.8829	0.8821	0.8813	0.8805	0.8796	0.8788	0.8780	0.8771	0.8763	0.8755
	tan	0.0524	0.0542	0.0559	0.0577	0.0594	0.0612	0.0629	0.0647	0.0664	0.0682		tan	0.5317	0.5340	0.5362	0.5384	0.5407	0.5430	0.5452	0.5475	0.5498	0.5520
4	sin	0.0698	0.0715	0.0732	0.0750	0.0767	0.0785	0.0802	0.0819	0.0837	0.0854	29	sin	0.4848	0.4863	0.4879	0.4894	0.4909	0.4924	0.4939	0.4955	0.4970	0.4985
	cos	0.9976	0.9974	0.9973	0.9972	0.9971	0.9969	0.9968	0.9966	0.9965	0.9963		cos	0.8746	0.8738	0.8729	0.8721	0.8712	0.8704	0.8695	0.8686	0.8678	0.8669
	tan	0.0699	0.0717	0.0734	0.0752	0.0769	0.0787	0.0805	0.0822	0.0840	0.0857		tan	0.5543	0.5566	0.5589	0.5612	0.5635	0.5658	0.5681	0.5704	0.5727	0.5750
5	sin	0.0872	0.0889	0.0906	0.0924	0.0941	0.0958	0.0976	0.0993	0.1011	0.1028	30	sin	0.5000	0.5015	0.5030	0.5045	0.5060	0.5075	0.5090	0.5105	0.5120	0.5135
	cos	0.9962	0.9960	0.9959	0.9957	0.9956	0.9954	0.9952	0.9951	0.9949	0.9947		cos	0.8660	0.8652	0.8643	0.8634	0.8625	0.8616	0.8607	0.8598	0.8589	0.8581
	tan	0.0875	0.0892	0.0910	0.0928	0.0945	0.0963	0.0981	0.0998	0.1016	0.1033		tan	0.5774	0.5797	0.5820	0.5844	0.5867	0.5890	0.5914	0.5938	0.5961	0.5986
6	sin	0.1045	0.1063	0.1080	0.1097	0.1115	0.1132	0.1149	0.1167	0.1184	0.1201	31	sin	0.5150	0.5165	0.5180	0.5195	0.5210	0.5225	0.5240	0.5255	0.5270	0.5284
	cos	0.9945	0.9943	0.9942	0.9940	0.9938	0.9936	0.9934	0.9932	0.9930	0.9928		cos	0.8572	0.8563	0.8554	0.8545	0.8536	0.8526	0.8517	0.8508	0.8499	0.8490
	tan	0.1051	0.1069	0.1086	0.1104	0.1122	0.1139	0.1157	0.1175	0.1192	0.1210		tan	0.6009	0.6032	0.6056	0.6080	0.6104	0.6128	0.6152	0.6176	0.6200	0.6224
7	sin	0.1219	0.1236	0.1253	0.1271	0.1288	0.1305	0.1323	0.1340	0.1357	0.1374	32	sin	0.5299	0.5314	0.5329	0.5344	0.5358	0.5373	0.5388	0.5402	0.5417	0.5432
	cos	0.9925	0.9923	0.9921	0.9919	0.9917	0.9914	0.9912	0.9910	0.9907	0.9905		cos	0.8480	0.8471	0.8462	0.8453	0.8443	0.8434	0.8425	0.8415	0.8406	0.8396
	tan	0.1228	0.1246	0.1263	0.1281	0.1299	0.1317	0.1334	0.1352	0.1370	0.1388		tan	0.6249	0.6273	0.6297	0.6322	0.6346	0.6371	0.6395	0.6420	0.6445	0.6469
8	sin	0.1392	0.1409	0.1426	0.1444	0.1461	0.1478	0.1495	0.1513	0.1530	0.1547	33	sin	0.5446	0.5461	0.5476	0.5490	0.5505	0.5519	0.5534	0.5548	0.5563	0.5577
	cos	0.9903	0.9900	0.9898	0.9895	0.9893	0.9890	0.9888	0.9885	0.9882	0.9880		cos	0.8387	0.8377	0.8368	0.8358	0.8348	0.8339	0.8329	0.8320	0.8310	0.8300
	tan	0.1405	0.1423	0.1441	0.1459	0.1477	0.1495	0.1512	0.1530	0.1548	0.1566		tan	0.6494	0.6519	0.6544	0.6569	0.6594	0.6619	0.6644	0.6669	0.6694	0.6720
9	sin	0.1564	0.1582	0.1599	0.1616	0.1633	0.1650	0.1668	0.1685	0.1702	0.1719	34	sin	0.5592	0.5606	0.5621	0.5635	0.5650	0.5664	0.5678	0.5693	0.5707	0.5721
	cos	0.9877	0.9874	0.9871	0.9869	0.9866	0.9863	0.9860	0.9857	0.9854	0.9851		cos	0.8290	0.8281	0.8271	0.8261	0.8251	0.8241	0.8231	0.8221	0.8211	0.8202
	tan	0.1584	0.1602	0.1620	0.1638	0.1655	0.1673	0.1691	0.1709	0.1727	0.1745		tan	0.6745	0.6771	0.6796	0.6822	0.6847	0.6873	0.6899	0.6924	0.6950	0.6976
10	sin	0.1736	0.1754	0.1771	0.1788	0.1805	0.1822	0.1840	0.1857	0.1874	0.1891	35	sin	0.5736	0.5750	0.5764	0.5779	0.5793	0.5807	0.5821	0.5835	0.5850	0.5864
	cos	0.9848	0.9845	0.9842	0.9839	0.9836	0.9833	0.9829	0.9826	0.9823	0.9820		cos	0.8102	0.8101	0.8101	0.8101	0.8101	0.8101	0.8101	0.8101	0.8101	0.8100
	tan	0.1763	0.1781	0.1799	0.1817	0.1835	0.1853	0.1871	0.1890	0.1908	0.1926		tan	0.7002	0.7028	0.7054	0.7080	0.7107	0.7133	0.7159	0.7186	0.7212	0.7239
11	sin	0.1908	0.1925	0.1942	0.1959	0.1977	0.1994	0.2011	0.2028	0.2045	0.2062	36	sin	0.5878	0.5892	0.5906	0.5920	0.5934	0.5948	0.5962	0.5976	0.5990	0.6004
	cos	0.9816	0.9813	0.9810	0.9806	0.9803	0.9799	0.9796	0.9792	0.9789	0.9785		cos	0.8090	0.8080	0.8070	0.8059	0.8049	0.8039	0.8028	0.8018	0.8007	0.7997
	tan	0.1944	0.1962	0.1980	0.1998	0.2016	0.2035	0.2053	0.2071	0.2089	0.2107		tan	0.7265	0.7292	0.7319	0.7346	0.7373	0.7400	0.7427	0.7454	0.7481	0.7508
12	sin	0.2079	0.2096	0.2113	0.2130	0.2147	0.2164	0.2181	0.2198	0.2215	0.2233	37	sin	0.6018	0.6032	0.6046	0.6060	0.6074	0.6088	0.6101	0.6115	0.6129	0.6143
	cos	0.9781	0.9778	0.9774	0.9770	0.9767	0.9763	0.9759	0.9755	0.9751	0.9748		cos	0.7986	0.7976	0.7965	0.7955	0.7944	0.7934	0.7923	0.7912	0.7902	0.7891
	tan	0.2126	0.2144	0.2162	0.2180	0.2199	0.2217	0.2235	0.2254	0.2272	0.2290		tan	0.7536	0.7563	0.7590	0.7618	0.7646	0.7673	0.7701	0.7729	0.7757	0.7785
13	sin	0.2250	0.2267	0.2284	0.2300	0.2317	0.2334	0.2351	0.2368	0.2385	0.2402	38	sin	0.6157	0.6170	0.6184	0.6198	0.6211	0.6225	0.6239	0.6252	0.6266	0.6280
	cos	0.9744	0.9740	0.9736	0.9732	0.9728	0.9724	0.9720	0.9715	0.9711	0.9707		cos	0.7880	0.7869	0.7859	0.7848	0.7837	0.7826	0.7815	0.7804	0.7793	0.7782
	tan	0.2309	0.2327	0.2345	0.2364	0.2382	0.2401	0.2419	0.2438	0.2456	0.2475		tan	0.7813	0.7841	0.7869	0.7898	0.7926	0.7954	0.7983	0.8012	0.8040	0.8069
14	sin	0.2419	0.2436	0.2453	0.2470	0.2487	0.2504	0.2521	0.2538	0.2554	0.2571	39	sin	0.6293	0.6307	0.6320	0.6334	0.6347	0.6361	0.6374	0.6388	0.6401	0.6414
	cos	0.9703	0.9699	0.9694	0.9689	0.9686	0.9681	0.9677	0.9673	0.9668	0.9664		cos	0.7771	0.7760	0.7749	0.7738	0.7727	0.7716	0.7705	0.7694	0.7683	0.7672
	tan	0.2493	0.2512	0.2530	0.2549	0.2568	0.2586	0.2605	0.2623	0.2642	0.2661		tan	0.8008	0.8127	0.8156	0.8185	0.8214	0.8243	0.8273	0.8302	0.8332	0.8361
15	sin	0.2588	0.2605	0.2622	0.2639	0.2656	0.2672	0.2689	0.2706	0.2723	0.2740	40	sin	0.6428	0.6441	0.6455	0.6468	0.6481	0.6494	0.6508	0.6521	0.6534	0.6547
	cos	0.9659	0.9655	0.9650	0.9646	0.9641	0.9636	0.9632	0.9627	0.9622	0.9617		cos	0.7660	0.7649	0.7638	0.7627	0.7615	0.7604	0.7593	0.7581	0.7570	0.7559
	tan	0.2679	0.2698	0.2717	0.2736	0.2754	0.2773	0.2792	0.2811	0.2830	0.2849		tan	0.8391	0.8421	0.8451	0.8481	0.8511	0.85				

Table 13—Trigonometric Functions—Concluded

Angle in degrees	Name of function	Value of function for each tenth of a degree										Angle in degrees	Name of function	Value of function for each tenth of a degree									
		0.0	0.1	0.2	0.3	0.4	0.5	0.6	0.7	0.8	0.9			0.0	0.1	0.2	0.3	0.4	0.5	0.6	0.7	0.8	0.9
50	sin	0.7660	0.7672	0.7683	0.7694	0.7705	0.7716	0.7727	0.7738	0.7749	0.7760	75	sin	0.9659	0.9664	0.9668	0.9673	0.9677	0.9681	0.9686	0.9690	0.9694	0.9699
	cos	0.6428	0.6414	0.6401	0.6388	0.6374	0.6361	0.6347	0.6334	0.6320	0.6307		cos	0.2588	0.2571	0.2554	0.2538	0.2521	0.2504	0.2487	0.2470	0.2453	0.2436
	tan	1.1918	1.1960	1.2002	1.2045	1.2088	1.2131	1.2174	1.2218	1.2261	1.2305		tan	3.7321	3.7583	3.7848	3.8118	3.8391	3.8667	3.8947	3.9232	3.9520	3.9812
51	sin	0.7771	0.7782	0.7793	0.7804	0.7815	0.7826	0.7837	0.7848	0.7859	0.7869	76	sin	0.9703	0.9707	0.9711	0.9715	0.9720	0.9724	0.9728	0.9732	0.9736	0.9740
	cos	0.6293	0.6280	0.6266	0.6252	0.6239	0.6225	0.6211	0.6198	0.6184	0.6170		cos	0.2419	0.2402	0.2385	0.2368	0.2351	0.2334	0.2317	0.2300	0.2284	0.2267
	tan	1.2349	1.2393	1.2437	1.2482	1.2527	1.2572	1.2617	1.2662	1.2708	1.2753		tan	4.0106	4.0408	4.0713	4.1022	4.1335	4.1653	4.1976	4.2303	4.2635	4.2972
52	sin	0.7880	0.7891	0.7902	0.7912	0.7923	0.7934	0.7944	0.7955	0.7965	0.7976	77	sin	0.9744	0.9748	0.9751	0.9755	0.9759	0.9763	0.9767	0.9770	0.9774	0.9778
	cos	0.6157	0.6143	0.6129	0.6115	0.6101	0.6088	0.6074	0.6060	0.6046	0.6032		cos	0.2250	0.2233	0.2215	0.2198	0.2181	0.2164	0.2147	0.2130	0.2113	0.2096
	tan	1.2799	1.2846	1.2892	1.2938	1.2985	1.3032	1.3079	1.3127	1.3175	1.3222		tan	4.3315	4.3662	4.4015	4.4373	4.4737	4.5107	4.5483	4.5864	4.6252	4.6646
53	sin	0.7986	0.7997	0.8007	0.8018	0.8028	0.8039	0.8049	0.8059	0.8070	0.8080	78	sin	0.9781	0.9785	0.9789	0.9792	0.9796	0.9799	0.9803	0.9806	0.9810	0.9813
	cos	0.6018	0.6004	0.5990	0.5976	0.5962	0.5948	0.5934	0.5920	0.5906	0.5892		cos	0.2079	0.2062	0.2045	0.2028	0.2011	0.1994	0.1977	0.1959	0.1942	0.1925
	tan	1.3270	1.3319	1.3367	1.3416	1.3465	1.3514	1.3564	1.3613	1.3663	1.3713		tan	4.7046	4.7453	4.7867	4.8288	4.8716	4.9152	4.9594	5.0045	5.0504	5.0970
54	sin	0.8090	0.8100	0.8111	0.8121	0.8131	0.8141	0.8151	0.8161	0.8171	0.8181	79	sin	0.9816	0.9820	0.9823	0.9826	0.9829	0.9833	0.9836	0.9839	0.9842	0.9845
	cos	0.5878	0.5864	0.5850	0.5835	0.5821	0.5807	0.5793	0.5779	0.5764	0.5750		cos	0.1908	0.1891	0.1874	0.1857	0.1840	0.1822	0.1805	0.1788	0.1771	0.1754
	tan	1.3764	1.3814	1.3865	1.3916	1.3968	1.4019	1.4071	1.4124	1.4176	1.4229		tan	5.1446	5.1929	5.2422	5.2924	5.3435	5.3953	5.4486	5.5026	5.5578	5.6140
55	sin	0.8192	0.8202	0.8211	0.8221	0.8231	0.8241	0.8251	0.8261	0.8271	0.8281	80	sin	0.9848	0.9851	0.9854	0.9857	0.9860	0.9863	0.9866	0.9869	0.9871	0.9874
	cos	0.5736	0.5721	0.5707	0.5693	0.5678	0.5664	0.5650	0.5635	0.5621	0.5606		cos	0.1736	0.1719	0.1702	0.1685	0.1668	0.1650	0.1633	0.1616	0.1599	0.1582
	tan	1.4281	1.4335	1.4388	1.4442	1.4496	1.4550	1.4605	1.4659	1.4715	1.4770		tan	5.6713	5.7297	5.7894	5.8502	5.9124	5.9750	6.0405	6.1066	6.1742	6.2432
56	sin	0.8290	0.8300	0.8310	0.8320	0.8329	0.8339	0.8348	0.8358	0.8368	0.8377	81	sin	0.9877	0.9880	0.9882	0.9885	0.9888	0.9890	0.9893	0.9896	0.9898	0.9900
	cos	0.5592	0.5577	0.5563	0.5548	0.5534	0.5519	0.5505	0.5490	0.5476	0.5461		cos	0.1564	0.1547	0.1530	0.1513	0.1495	0.1478	0.1461	0.1444	0.1426	0.1409
	tan	1.4826	1.4882	1.4938	1.4994	1.5051	1.5108	1.5166	1.5224	1.5282	1.5340		tan	6.3138	6.3859	6.4596	6.5350	6.6122	6.6912	6.7720	6.8548	6.9395	7.0264
57	sin	0.8387	0.8396	0.8406	0.8415	0.8425	0.8434	0.8443	0.8453	0.8462	0.8471	82	sin	0.9903	0.9905	0.9907	0.9910	0.9912	0.9914	0.9917	0.9919	0.9921	0.9923
	cos	0.5446	0.5432	0.5417	0.5402	0.5388	0.5373	0.5358	0.5344	0.5329	0.5314		cos	0.1392	0.1374	0.1357	0.1340	0.1323	0.1305	0.1288	0.1271	0.1253	0.1236
	tan	1.5399	1.5468	1.5537	1.5607	1.5677	1.5747	1.5818	1.5889	1.5961			tan	7.1154	7.2066	7.3002	7.3962	7.4947	7.5958	7.6996	7.8062	7.9158	8.0285
58	sin	0.8480	0.8490	0.8499	0.8508	0.8517	0.8526	0.8536	0.8545	0.8554	0.8563	83	sin	0.9925	0.9928	0.9930	0.9932	0.9934	0.9936	0.9938	0.9940	0.9942	0.9943
	cos	0.5299	0.5284	0.5270	0.5255	0.5240	0.5225	0.5210	0.5195	0.5180	0.5165		cos	0.1219	0.1201	0.1184	0.1167	0.1149	0.1132	0.1115	0.1097	0.1080	0.1063
	tan	1.6003	1.6066	1.6128	1.6191	1.6255	1.6319	1.6383	1.6447	1.6512	1.6577		tan	8.1443	8.2636	8.3863	8.5126	8.6427	8.7769	8.9152	9.0579	9.2052	9.3572
59	sin	0.8572	0.8581	0.8590	0.8599	0.8607	0.8616	0.8625	0.8634	0.8643	0.8652	84	sin	0.9945	0.9947	0.9949	0.9951	0.9952	0.9954	0.9956	0.9957	0.9959	0.9960
	cos	0.5150	0.5135	0.5120	0.5105	0.5090	0.5075	0.5060	0.5045	0.5030	0.5015		cos	0.1045	0.1028	0.1011	0.0993	0.0976	0.0958	0.0941	0.0924	0.0906	0.0889
	tan	1.6643	1.6709	1.6775	1.6842	1.6909	1.6977	1.7045	1.7113	1.7182	1.7251		tan	9.5144	9.6768	9.8448	10.0119	10.199	10.3865	10.579	10.780	10.985	11.025
60	sin	0.8660	0.8669	0.8678	0.8686	0.8695	0.8704	0.8712	0.8721	0.8729	0.8738	85	sin	0.9962	0.9963	0.9965	0.9966	0.9968	0.9969	0.9971	0.9972	0.9973	0.9974
	cos	0.5000	0.4985	0.4970	0.4955	0.4939	0.4924	0.4909	0.4894	0.4879	0.4863		cos	0.0872	0.0854	0.0837	0.0819	0.0802	0.0785	0.0767	0.0750	0.0732	0.0715
	tan	1.7321	1.7391	1.7461	1.7532	1.7603	1.7675	1.7747	1.7820	1.7893	1.7966		tan	11.430	11.665	11.909	12.163	12.429	12.706	12.996	13.300	13.617	13.951
61	sin	0.8746	0.8755	0.8763	0.8771	0.8780	0.8788	0.8796	0.8805	0.8813	0.8821	86	sin	0.9976	0.9977	0.9978	0.9979	0.9980	0.9981	0.9982	0.9983	0.9984	0.9985
	cos	0.4848	0.4833	0.4818	0.4802	0.4787	0.4772	0.4756	0.4741	0.4726	0.4710		cos	0.0698	0.0680	0.0663	0.0645	0.0628	0.0610	0.0593	0.0576	0.0558	0.0541
	tan	1.8040	1.8115	1.8190	1.8265	1.8341	1.8418	1.8495	1.8572	1.8650	1.8728		tan	14.301	14.669	15.056	15.464	15.895	16.350	16.832	17.343	17.886	18.465
62	sin	0.8829	0.8838	0.8846	0.8854	0.8862	0.8870	0.8878	0.8886	0.8894	0.8902	87	sin	0.9986	0.9987	0.9988	0.9989	0.9990	0.9990	0.9991	0.9992	0.9993	0.9993
	cos	0.4693	0.4679	0.4664	0.4648	0.4633	0.4617	0.4602	0.4586	0.4571	0.4555		cos	0.0523	0.0506	0.0488	0.0471	0.0454	0.0436	0.0419	0.0401	0.0384	0.0366
	tan	1.8807	1.8887	1.8967	1.9047	1.9128	1.9210	1.9292	1.9375	1.9458	1.9542		tan	19.081	19.740	20.447	21.205	22.022	22.904	23.859	24.898	26.031	27.272
63	sin	0.8910	0.8918	0.8926	0.8934	0.8942	0.8949	0.8957	0.8965	0.8973	0.8980	88	sin	0.9994	0.9995	0.9995	0.9996	0.9996	0.9997	0.9997	0.9997	0.9998	0.9998
	cos	0.4540	0.4524	0.4509	0.4493	0.4478	0.4462	0.4446	0.4431	0.4415	0.4399		cos	0.0349	0.0332	0.0314	0.0297	0.0279	0.0262	0.0244	0.0227	0.0209	0.0192
	tan	1.9626	1.9711	1.9797	1.9883	1.9970	2.0057	2.0145	2.0233	2.0323	2.0413		tan	28.636	30.145	31.821	33.694	35.801	38.189	40.917	44.066	47.740	52.081
64	sin	0.8988	0.8996	0.9003	0.9011	0.9018	0.9026	0.9033	0.9041	0.9048	0.9056	89	sin	0.9998	0.9999	0.9999	0.9999	0.9999	1.0000	1.0000	1.0000	1.0000	1.0000
	cos	0.4384	0.4368	0.4352	0.4337	0.4321	0.4305	0.4289	0.4274	0.4258	0.4242		cos	0.0175	0.0157	0.0140	0.0122	0.0105	0.0087	0.0070	0.0052	0.0035	0.0017
	tan	2.0503	2.0594	2.0686	2.0778	2.0872	2.0965	2.1060	2.1155	2.1251	2.1348		tan	57.290	63.657	71.615	81.847	95.490	114.59	143.24	190.98	286.48	572.96
65	sin	0.9063	0.9070	0.9078	0.9085	0.9092	0.9100	0.9107	0.9114	0.9121	0.9128	90	sin	1.0000	1.0000	1.0000	1.0000	1.0000	1.0000	1.0000	1.0000	1.0000	1.0000
	cos	0.4226	0.4210	0.4195	0.4179	0.4163	0.4147	0.4131	0.4115	0.4099	0.4083		cos	0.0000	0.0000	0.0000	0.0000	0.0000	0.0000	0.0000	0.0000	0.0000	0.0000
	tan	2.1445	2.1543	2.1642	2.1742	2.1842	2.1943	2.2045	2.2148	2.2251	2.2355												
66	sin	0.9135	0.9143	0.9150	0.9157	0.9164	0.9171	0.9178	0														

Table 14—Residential Underground Distribution Design Practice of 28 Electric Light and Power Companies*

COMPANY	Appalachian Elec Pwr	Boston Edison	California Elec Pwr	Public Service Div. Commonwealth Edison	Public Service Div. Commonwealth Edison	Consumers Pwr	Dallas Pwr & Light	Dayton Pwr & Light	Detroit Edison	Company "X"
Type of area.....	Residential, single	Residential	Deluxe residential	Residential, single	Deluxe single resid's	Deluxe single resid's	Deluxe single resid's	Deluxe single resid's	Deluxe residential	Resid'l single; group
Primary Voltage, kv.....	7.2/12.5	4.8 and .116	3-in. non-met duct	2.4/4.16	7.62/13.2	4	4.8 open delta Dir burial	4	4.8 open delta Dir burial	4.16
Duct or buried.....	Buried, screened soil	36	30 Min.	36-42	30	30	30	30	36	42 Min.
Depth, inches.....	Creo board over sec.	Concrete, earth	Earth; concrete at crossings	Soil	Screened earth; slab	Screened earth; slab	Screened earth; slab	Screened earth; slab	Crown tile	Street
Cover.....	Street	Pri junction box, concrete	Street	Usually parkways	Rear lot	Rear lot	Rear lot	Rear lot	Rear lot	Manholes
Manhole or handhole.....	None	Radial	Radial	None	None	None	None	None	Primary ring	Radial
Type system.....	Radial	Radial	Radial	Porcelain disc on in	Radial	Radial	Radial	Radial	Primary ring	Radial
Seet energizing.....	None	Positected cutouts in manholes; tlf encls	Positected cutouts in manholes; tlf encls	Porcelain disc on in tlf encls	UG pri sect'liz'd manually at tlf bank	UG pri sect'liz'd manually at tlf bank	UG pri sect'liz'd manually at tlf bank	UG pri sect'liz'd manually at tlf bank	Discon pothead in kiosk	Yes, with emerg transfer on primary
Cable Description										
Size & conductor	No. 6 Cu	1/2 2/0; No. 2; 6	1/2 2/0; No. 2; 6	2/c conc No. 6; 1/0 Cu	No. 6 Cu	No. 6 Cu	No. 6 Cu	1/c No. 2 Cu	3/c No. 2	2/c; 4/c No. 6 Cu
Insulation.....	11/64 ozone resist, shielded	10/64 syn 5-kv shielded	10/64 syn 5-kv shielded	9/64 corona resist rubber	3/64 corona resist rubber	3/64 corona resist rubber	3/64 corona resist rubber	16/64 VC 15 kv	7/64 VC	Paper; lead
Jacket.....	5/64 Neoprene	4/64; 5/64 Neoprene	4/64; 5/64 Neoprene	3/64 Neoprene	3/64 Neoprene	3/64 Neoprene	3/64 Neoprene	Lead	5/64 lead; Neoprene	None
Neut cond.....	Separate common	No. 2; 4 bare	No. 2; 4 bare	7 No. 14; 20 No. 14 bare Cu concent over jacket	7 No. 14 lined Cu armor wires, spiral	7 No. 14 lined Cu armor wires, spiral	7 No. 14 lined Cu armor wires, spiral	No. 2 WP common	None	None
Lightning Protection.....	At OH connect only	At OH connect only	At OH connect only	At OH & tlf connect	At OH connect; tlf	At OH connect; tlf	At OH connect; tlf	At OH connect only	At tlf	At OH connect only
Cable connect at oil cutout in tlf encls	Shielded; tlf encls	Shielded; tlf encls	Shielded; tlf encls	Cable ann left clear	Cable ann left clear	Cable ann left clear	Cable ann left clear	Wiping sleeves in tlf or oil cutout	Directly to tlf	Bobheads at term pole Wiping sleeves at tlf
Secondary Mains										
Voltage	120/240, 3-w	120/240	120/240	120/240	120/240	120/240	120/240	120/240	120/240 3-φ	120/240 3-φ
Duct or buried.....	Dir buried, screened soil, board cover	Fiber pipe in fine dirt; filled with comp lead, plank cover	2-in. duct	Dir burial	Dir burial	Dir burial	Dir burial	Duct bank with pri	Dir burial	42 min Street
Depth, inches.....	36	30	30	36 or 6 above pri	36 or 6 above pri	36	36	Duct bank with pri	36	42 min Street
Location.....	Side of street	Street	Street	Street	Street	Separate trench	Separate trench	Duct bank with pri	Rear lot lines	Street
In primary trench.....	Yes	Some	Some	Yes, if on same route	Yes, if on same route	No	No	Yes	Yes	Street
Cable Description										
Size & conductor	4/0 Cu	1/0 to 4/0 Cu	No. 2 Cu	1/0 Cu	1/0 Cu	1/0 Cu	No. 1/0; 300 MCM Cu	4/c 4/0; 4/c 1/0	2-1/c 250 MCM, 2-1/c 500 MCM
Insulation.....	5/64 RHRW	5/64 Rubber	4/64 thermo-plastic or RHRW Neoprene	4/64 RH	5/64 RHRW	5/64 RHRW	5/64 RHRW	RHRW Neoprene jacket	3/64 RHRW	Paper; lead
Jacket.....	4/64 Neoprene	Double braid	4/64 thermo-plastic or RHRW Neoprene	3/64 Neoprene	3/64 Neoprene	3/64 Neoprene	3/64 Neoprene	Neoprene IPCEA Common	3/64 Neoprene
Neut cond.....	2/0 bare	No. 4-1/0 bare tinned Cu	No. 4 bare Cu	No. 2 bare Cu	No. 2 bare Cu	4/0; 1/0 rubber; Neoprene	Sep'te neat 4/0 bare
Services										
Size & differ- main.....	No. 7 Min.	2 No. 6 in iron pipe R&L; No. 6 bare Cu	As required by load	3-w No. 2 recom. insula; jacket same	Installed by customer	2-1/c No. 3 paper; lead; No. 3 bare
Owned by customer.....	Yes	Yes	2/3	Yes	Yes	Yes	Yes	Yes	Yes	Conduit cust owned except for multiple dwell
Connection arrangement.....	Crab joint in 30-in. concrete handhole	To main in buried wood box filled with comp.	Dir from tlf sec bus; bur'd sec serv box	Dir. No box; pedestals	To fused terminal in junction box	In manholes	Through fuses at serv pedestal	Joined in manholes
Transformers										
Type	OH conv, sealed tank	Subway	OH CSP, no arrester	OH CSP usually	Conv	Conv	CSP OH type	Usually subway	SP OH type	Subway
Size, kva.....	25-37½	25-50	5-50	15-50	37½ Max	Max 3-φ bank 1-25;	25-50	5-50	25-100
Enclosure.....	48 in bur'd conc pipe	Manhole	Corrugated steel on conc base; semi-bur'd	Conc tile above or part above grd	Semi-bur'd conc box	Semi-bur'd conc box	Semi-bur'd vault	Manholes	Kiosk	Manholes
Sectionalizing at tlf.....	None	None	Sec. switching	Usually	Gain cover isolating links	Gain cover isolating links	Pri manually sect'lized at tlf bank	None. Pri manually sect'lized at tlf bank	Sec fuses only	Oil cutout at tlf
Street Lighting.....	Control cable in trench with sec	In split fiber duct with sec	Same trench	Independent	None yet	None yet	None	Separate	Pedestal to light via property line	Series cir in duct bank with pri; sec
Telephone Cable									Same trench	Separate
Cost Ratio, UG/OH.....	3:2:1	2.5 to 5:1	2 or 3:1	3.5:1	3.5:1	2.5:1	2.5 to 5:1	Depends on conditions

Continued on next page

*Permission has been granted by *Electrical World* to include this material.

Table 14—Residential Underground Distribution Design Practice of 28 Electric Light and Power Companies*—Continued

COMPANY	Hawaiian Electric	Iowa Electric L&P	Jackson, Tenn., Municipal System 1951	Kansas City P & L 1951	Long Island Lighting	Los Angeles Dept. W & P	New Orleans P S	Northern States Pwr
Type of area.....	Deluxe single resid's	Apartment	Single residences	Deluxe single resid's	Single resid trench	Single residences	Deluxe single resid's	Deluxe single resid's
Primary Voltage, kv.....	2.4/4.16	2.4/4.16	2.4/4.16	2.4/4.16	2.4/4.16	4.8	13.8	2.4/4.16
Duct or buried.....	Dir burial multiple	Dir burial	Dir burial	Dir burial	Dir burial	Transite	Duct; manhole system	Duct; dir burial
Depth, inches.....	24	30	24-30	36	24	30	36	24-36
Cover.....	Screened soil; silt	4-in. sand; cros plank	Old crosso	Soil	Soil	Soil	Soil	Soil; cros plank
Location.....	Inside of sidewalk	Vaults in rear	Old crosso	Rear lot	Rear lot	Rear lot	Blk sidewalk & curb	Rear lot; street
Manhole or vault.....	None	Vaults in rear	None	None	None	None	Yes	Both
Type system.....	Loop; transfer manual	Radial	Loop	Loop	Tsf vault	Radial	Open loop	Radial
Sectionalizing.....	Discon at ttf	None	Discon poth'd in vault	Loop	Sect'lizing switches	None	Load break switch	Yes
Cable Description								
Size & conductor	1/2 No. 4; 1/0; 4/0; 350 MCM Cu	No. 6 Cu 5 kv	No. 4 Cu	1/2 No. 8	13.2 kv 1/2 No. 4	3/2 No. 6	No. 2 Cu
Insulation.....	On 350 MCM-11/64 RI	10/64 rubber 5 kv non-shielded	19/64 rubber 15 kv shielded	8/64 Polyethylene	13.2 kv-220 mill paper	Paper	Rubber-D-574 shielded Neoprene	PILC
Jacket.....	Neoprene No. 4-4/64; 1/0; 4/0-5/64; 350 MCM 6/64	3/64 in Neoprene	5/64 in Neoprene	4/64 in PVC	4.16 kv-110 mill paper Neoprene	Lead
Neut cond.....	Bare common; 1/2 size of largest prl or sec	No. 6 WP	No. 4 bare same duct	Common neut	Neut common with sec
Lightening protection.....	At OH connect only	At OH connect only	At OH connect only	At OH connect only	At OH connect only	None	On OH connect only	At OH connect only
Cable termination.....	Stress cone	Dir tape connect	Pothead at ttf	1/c pothead	Pothead at pole	Connected to discon
Secondary Mains								
Voltage.....	120/240	120/240	120/240	115/230	115/230	120/240	120/240	120/240
Duct or buried.....	Dir burial; silt	Dir burial	No sec	Dir burial	Dir burial	Transite duct	Duct	Dir burial
Depth, inches.....	24	30	With prl	24	30	30-36
Location.....	Same as prl	Parkway	Same trench as prl	Rear lot	Parkway with prl
In primary trench.....	Yes, 1 ft from prl	Yes	Yes	Yes	Yes
Cable Description								
Size & conductor	1/2 No. 4/0 Cu	1/0 Cu	3/2 1/0 to 300 MCM	1/2 No. 2-1/2 1/0; 4/0	2-1/2 600 v	4/0 Cu	System purchased
Insulation.....	5/64 rubber 600 v	600 v Dionite	4/64-in.; 5/64 in. rub	Rubberlike	5/64-in. rub	Values unknown
Jacket.....	4/64 Neoprene	3/64-in. Neoprene	3/64 in. Neoprene	4/64-in. Neoprene
Neut cond.....	Bare common; 1/2 size of largest prl or sec	No. 4 bare Cu	Separate 4/0 4/64-in. Neoprene
Services								
Size & differ- main.....	2/2 No. 4 RIV 600-v; 4/64-in. and 1/0	1/0; No. 3 Cu same insul jacket as sec	Services dir from vault return on wall of vault	Rubberlike	Owner's choice	Similar
Owned by customer.....	Yes	No	Yes	Yes	Yes	No	Yes	Yes
Connection arrangement.....	Moller in concrete box	8-in. tile; junct box 6 in. below surface	In meter socket	Junct box	Busbar on pedestal on prl	In manhole at curb	Buried
Transformers								
Type.....	OH consent	OH CSP less arresters	OH CSP less arresters	CSP	OH CSP less arresters	Overhead CSP	OH consent	Most consent on poles; subway in manholes
Size, kva.....	100-Max	50-max	50 max	25 kva	1-167, 2-100 kva	Some manholes
Enclosure.....	Steel cylinder & concrete pipe base 2/2 buried	38-in. conc tile semi-buried	38-in. conc tile semi-buried	Inverted metal container on pad	Brick house above prl
Stationary switching at ttf.....	2 pole cutouts in transfer arrangement	None	Pothead at ttf	No-load switching	None	None	Open disc each way
Street Lighting.....	Independent	No	None as yet	No	None as yet	No	Cable in duct bank
Telephone Cable.....	Same trench, sep cond	Rear property	Generally separate	Same trench, 12-in. sep	Same trench, 12-in. sep	Separate
Cost Ratio U.C./O.H.....	2.5 to 6:1	3:1	3:1	2.2:1	2.1 to 5:1	2.1 to 4:1	10:1 to 12:1

*Permission has been granted by Electrical World to include this material. Continued on next page

Table 14—Residential Underground Distribution Design Practice of 28 Electric Light and Power Companies*—Continued

COMPANY	Pacific G & E	Pennsylvania P&L	Philadelphia Electric	Puget Sound P & L	So. California Edison	Union Electric	Utah P & L	The Public Utilities Comm. of London, Ontario	Hydro Electric Power Comm of Ontario	City of Calgary Alberta
Type of area.....	Deluxe residences	Deluxe residences	Apartm'ts	Resid'l	Resid'l subdiv	Resid	Deluxe single resid's	Residence	New resid's
Primary Voltage, kv.....	2.4/4.16	2.4/4.16	2.4/4.16	2.4/4.16	2.4/4.16	2.4/4.16	7.2/12.47	4.16	4.16	2.4/4.16
Duct or buried.....	3 in. non-met. No conc	Fiber in conc; dir burial	3-in. fiber, no conc	Min 2 in non met duct, conduit	3-in. fiber duct; in conc	Transite duct; no conc	Fiber in conc	2 in fiber in conc	Transite duct	Transite
Depth, inches.....	30	30	24	24 min	24	30	9	9
Cover.....	Street	Street	In sidewalk	Sand; treated plank	Soft conc envelope under streets	Soil	Soil	Sidewalk	Sidewalk	Earth
Location.....	Street, rear lot	Street	Rear lot	Rear lot	Parkway	Rear lot	Under street edge	Under street edge
Manhole or manhole vault.....	Prestab conc serv box	Manholes, handholes	None	4 x 2 1/2 x 3-ft, pull box	Manholes	Semi-buried tef house	Handholes at crossings	Handholes at crossings	Manhole
Type system.....	Loop; radial	Radial	Sectionalized radial	Radial from OH	Radial	Radial	Radial	Radial	Manhole
Sectionalizing.....	Porc box discon OH	Several sect each bf from cliff OH point	Oil fuse CO	Looped through vt	None	At tef vt	No	No	Yes
Cable Description	1/c No. 6 to 1/c No. 2	1/c No. 6 to 1/c 1/0	1/c No. 4 Cu min	3/c No. 2 Cu mains 1/c No. 6 tere	No. 6 Cu 11/64-in. oil base rub	No. 4 Cu	1/c No. 6 Polyethylene	1/c No. 6; No. 2 Polyethylene	1/c No. 6 Polyethylene
Insulation.....	Oil base; ozone resist comp. 5 kv ahead IPCEA	VC-PV or rub LC—5 kv	Syn. RI IPCEA	Rubberlike
Jacket.....	Neoprene IPCEA spec	Lead	Lead	Syn rubber	Neoprene	4/64-in. Neoprene	Shielded Cu tape, 5/64-in. Neoprene	No jacket	No jacket	No jacket
Neut cond.....	Bare. Same size, same conduit as instl phase	Bare	Bare Cu separate	No. 4 WP min	No. 4 WP Cu for mains No. 6 WP Cu for taps	6 No. 11 lead Cu spiral wound	No. 6 bare	No. 6 WP or larger	No. 4 WP
Lightning Protection.....	None	At OH connect only	Connected to oil fuse CO or LC tef lead	None	At OH connect only in porc box CO	At OH connect only	At OH connect only	At OH connect only	At OH connect only
Cable termination.....	Stress cones	G & W oil fused CO	CO or LC tef lead	In porc box CO	Dir into porc CO	Dir into porc CO	Dir into porc CO	Dir into porc CO
Secondary Mains Voltage.....	120/240	120/240	Sec mains not used; Serv dir from bf.	120/240	120/240	120/240	No sec	115/230
Duct or buried.....	3-in. non-met	Duct	None	Fiber duct	Transite duct	Customers bring serv to tef	Dir burial; covered with center blocks	Buried; closed loops from each tef	Dir burial
Depth, inches.....	30	30	24 in. min.	Above pri ducts	24 in. Parkway	6 to 9	6 to 9	36
Location.....	Same as pri	Streets	Lot	Same duct	Rear of building	Under sidewalk edge.
In primary trench.....	Yes	Same duct	Same duct	Generally not	Yes
Cable Description	1/c 1/0; 250 MCM	1/c; 2/c 600 V	2 1/0 Cu min to 250 MCM and 2/0 neut	4/0	1/c No. 2	1/0	No. 2
Insulation.....	Oil base; ozone resist comp 600 v—IPCEA	L&R; Rub & Neoprene	Non-lead rub	Rubberlike	5/64-in. rubber	Polyvinylchloride	Polyvinylchloride	Polyvinylchloride
Jacket.....	Neoprene IPCEA	Neoprene	3/64-in. Neoprene	No jacket	No jacket	No jacket
Neut cond.....	Separate No. 2 bare Cu, 1/0	Bare common	No. 2 Cu for 1/0 ph No. 2 Cu for 250 MCM	Common with pri	Common with pri	Bare neut
Services	Customer specifics	Dir burial	No. 2 min dir burial	1/c No. 4, rubberlike insul 3/c twisted	No. 2; 1/0 dir burial	Supplied by customer	Same trench as sec	2 No. 4 PVC; 1-No. 6 bare neut	2-No. 2 PVC 1-No. 4 WP
Owned by customer.....	Yes	Yes	Bus at tef	Yes	Split-bolt or indent type con for term box	Yes to property line Split-bolt in handhole taped	Yes	No	No
Connection arrangement.....	Various. Split-bolt con usual	Bugged & taped; or soldered	Bus at tef	Junct box	Connect box on basement wall outside	Solderless-taped; in aliphatic filled box
Transformers	OH	Convent; submersible	OH	OH	CP	CSP less arrester	OH CP	Standard OH	Convent or CSP OH	CSP
Type.....	One block; brick below surface	50 kva max. Neoprene 1/2 in. conc tile semi-buried	15-25 Semi-buried tef vault at corner blocks	15-100	Up to 100	Up to 100
Size, kva.....	3 x 5 x 4-ft. sheet steel	Manholes	Yes	Reinforcing blocks, semi-buried conc	Reinforcing blocks, semi-buried conc
Enclosure.....	None	Yes	No	For multiple tef	S&C Post-tet fuses	Fused porc box CO	Fused porc box CO
Sectionalizing and switching at tef.....	Yes. At bf as above	Yes	Cable buried with pri	None yet	Separate system	None as yet.	Yes. Connect to CO	Yes. With sec	Yes. With sec
Street Lighting.....	Independent	Yes	Same trench 12 in sep	Separate trench	Same duct run	No	Yes. With sec	Yes. With sec
Telephone Cable.....	Same trench often	Adjacent ducts	Same duct line	No	No
Cost Ratio, UG/OH.....	Was 2:1; is 4:1 to 5:1	3:1	3 to 5:1	4:1	1.25:1 (1947)	1.22:1	3:1

*Permission has been granted by Electrical World to include this material.

Table 15—Application Data For Lightning Arresters**

Classification of Systems

THIS TABLE, based on calculation and experience, is a guide for quick selection of lightning arresters. For the purpose of selecting the proper lightning arrester voltage rating, three-phase systems may be classified as Type A, Type B, etc., on the basis of the magnitudes of the ratios X_0/X_1 and R_0/X_1 .

Type A neutral grounded systems are usually well grounded and have a reactance and resistance ratio less than for the Type B systems. The system constants are not known with sufficient detail to establish the limiting ratios. These systems are specifically the grounded Y-distribution systems using distribution-type arresters, for which the application practice has been established by experience.

Type B neutral grounded systems have a reactance ratio X_0/X_1 which is positive and less than 3 and a resistance ratio R_0/X_1 which is positive and is less than 1. These limits correspond to the usually accepted definition of an "effectively grounded" system.

Type C neutral grounded systems have either the reactance ratio greater than plus 3 or the resistance greater than plus 1, or both; systems using ground fault neutralizers are included in this class.

Type D isolated neutral systems are the usual ungrounded systems for which the zero sequence reactance is capacitive, and the ratio X_0/X_1 is negative and lies between minus 40 and minus infinity.

The values of maximum system voltages in the column for Type D systems are those recommended if the risk of abnormal voltages in excess of the arrester rating is to be avoided. However, it has been the general practice to use the same values for Type D isolated neutral systems as used for the Type C neutral grounded systems.

Type E isolated neutral systems are those ungrounded neutral systems that have a reactance ratio X_0/X_1 that is negative and is between 0 and minus 40, over which range partial resonance may occur so that each case must be analyzed and treated upon its own merits.
Example: A 12,000-volt system has a maximum

voltage of 12,500 volts. From the table, a Type A system would require a 9,000-volt arrester; a 12,000-volt arrester is required for a Type B system; and if the system is either a Type C or Type D a 15,000-volt arrester is required.

Lightning Arrester Rating	Maximum three-phase system voltage on which arrester should be used				
	Systems with neutrals grounded			Systems with neutrals isolated	
	Type A	Type B	Type C	Type D	Type E
Volts rms					
175	130/260*	130/260*	
175	260	220	
650	650	650	650	650	
1,000	1,000	1,000	1,000	1,000	
3,000	4,500	3,750	3,000	2,700	
6,000	9,000	7,500	6,000	5,500	
9,000	12,800	11,250	9,000	8,200	
12,000	15,000	15,000	12,000	11,000	
15,000	18,000	18,000	15,000	13,000	
Kv rms					
20	Type A systems usually do not occur in these voltages.	25	20	18	Each case requires special study.
25		30	25	23	
30		37	30	27	
37		46	37	34	
40		50	40	36	
50		60	50	45	
60		73	60	55	
73		90	73	66	
97		121	97	88	
109		136	109	99	
121		150	121	110	
145		180	145	132	
169		200	169	...	
195		245	195	...	
242	300	242	...		

*Single-phase, three-wire.
**This Table is reproduced in part from EEI Publication No. R-6 or NEMA Publication No. 117, May 1949.

INDEX

	PAGE		PAGE		PAGE
Absorption Factor	496	Booster Transformers	223	Circuit Breakers (continued)	
Accuracy Class, Instrument Transformers	478, 479, 480	Boric Acid Power Fuses	377, 378, 379, 398, 399	Primary Network	113
ACSR		Brightness	495	Selective Tripping	417 to 423
Annealing	371	Bulk Power Stations	1	Cascading	426
Current Carrying Capacity	534	Burden, Instrument Transformers	470, 472, 473, 477, 479, 485, 490, 491	Example	419 to 423
Active Power	21	Burning Clear Secondary Faults		One-Line Diagram	418
Aerial Cable		Banked		Time-Current Characteristics	418
Characteristics	544	Secondaries	138, 139, 406, 407	Short-Time Current	388
Overhead Network	183	Overhead Networks	182	Trip-Free Control	383
Secondary Circuit	130	Underground Networks	151 to 153	Tripping, Reverse-Current	388
Air Circuit Breakers, Low Voltage		Bus Regulation	122, 271, 272	Unlatching Time	384, 386, 387
Application	420, 421, 422	Cable		Circuit Connections, Watthour Meters	
DB Type	384, 389	Aerial	130, 183	Self-Contained	448, 449
Aluminum Conductor		Characteristics		Transformer Rated	450, 451
Annealing	371	of	537 to 543, 545	Circuit Reclosers, Automatic	380, 381
Characteristics	533	Current Capacity of 600v Cable	174	Control Schemes	381
Current Carrying Capacity	533	Secondary Network	151, 174	Cooling Effect	410
Apparent Power	20, 21	Service, Self Supporting	135, 136	Coordination with	
Arc Furnace		Street Lighting	510	Fuses	410, 414 to 417
Demand Charts	351	Underground, Residential	145	Ground Trip Device	381
Electrical Characteristics	352	Candle Power	495	Interrupting Current Rating of	381
Series Capacitor Application	354	Capability		Loop Radial Primary	113, 124
ASA Guide-Transformer		Distribution Substation	72	Sequence of Operation	381
Loading	195, 201, 241 to 244	Subtransmission Line	91	Shunt Lockout Device	381
ASA Standards		Capacitors (See <i>Series and Shunt Capacitors</i>)		Coincidence Factor	
Transformer Terminal	206	(See <i>Power Capacitors</i>)		Application	35 to 38
Voltage Regulators	285	Cascade Arrangement—Circuit Breakers	425, 426	Copper Loss Calculation	246
Automatic Control, Shunt Capacitors		Cascading—Banked Secondary	406	Definition	25
Time-Switch	286, 317, 324	Cascading—Street Lighting	510	Infinite Number of Load	42, 43
Voltage	286, 287, 317, 325	Application	510	Load Estimation	42, 43
Auto Transformers—		Transformers	510	Transformer	246
Equivalent Circuit	549, 550	Circuit Breakers		Coincident Demand	3, 23
Average Phasor Power	22	Cascade Arrangement	425, 426	Compensators	
Ballasts	498, 501, 514	Characteristics of	388	Line-Drop	465
High-Reactance Type	514	Clearing Time	384, 386, 387	Transformer Loss	287 to 294
Reactor Type	514	Control Voltage	389	Condensers—	
Band Width, Regulator		Coordination—		(See <i>Synchronous Condensers</i>)	
Effective	285, 286	DB Breaker with Fuses	418	Conductor Burndown	367, 368, 369, 371
Induction-Type	283	CSP Transformer	397, 400	ACSR (annealing)	371
Step-Type	283	Definition	370	Aluminum (annealing)	371
Banked Secondary System	11, 137 to 142	De-ion Arc Chamber	384	Solid Copper	368, 369
Advantages	138	Draw-out Type	48	Stranded Copper	369, 370
Burning Clear		Duty Cycle	388	Conductor Size	
of Faults	138, 139, 406, 407	Feeder	48	Secondary Main	151
CSPB Transformers	139, 406	Interrupting Current	384, 388	Series Street Lighting	509, 510
D-C Board Use	140	Loop Radial Primary	112	Constant Current Transformers	504 to 507
Definition	137, 138	Loop Tie	112	Capacity Calculations	
Economics	133, 134	Low Voltage Air		Electric—Discharge Lamp	
Fault Current	138, 406, 407	Application	420, 421, 422	Load	520 to 524
Flexibility for Load Growth	139	Coordination with Fuses	418	Examples	522 to 524
Fused Protection	406, 407	Rating	384, 389	General Procedure	521 to 522
Load Density	138	Tripping Characteristics	390, 391	Incandescent Lamp	
Load to Transformers	140	Main Secondary	425	Load	518 to 520
Planning	140 to 142	Mid-Tie	114	Kw Required for Starting	521
Secondary—Main Impedance	142	Molded Case		Mixed Load	512 to 524
Service Reliability	138	(AB De-Ion)	383, 384, 385	Number of Series-Mercury Transformers per C.C.	
Voltage Dip by Motor Starting	141	Operating Current	389	Transformer	521, 522
Voltage Dip Reduction	138, 141	Power	389	Construction	504, 505
Banked Transformers (See <i>Banked Secondary System</i>)				CSPH	506, 507
Blondel's Theorem	435			Current Regulation	506
				Dielectric Test	506
				Impedance	506

	PAGE		PAGE		PAGE
Constant Current Transformers		Cost (continued)		Current Transformers (continued)	
(continued)		Spot Network System.....	195, 197	Transformer Correction	
Load to.....	506, 518, 519	Spot Network Unit.....	195, 197	Factor.....	478, 479
Loading Curve.....	518, 519	Step-Type Feeder Regulator.....	274	Vector Diagram.....	477
Loss.....	506	Street Lighting.....	526 to 530	Cutouts, Distribution	
Losses in Cable.....	519	Substation Voltage		Characteristics of.....	370
Pole Type—Characteristics.....	506, 508	Regulators.....	273, 274, 275	Dropout-Type.....	376, 377
Primary Voltage Variation.....	506	Subtransmission.....	103 to 107	Expulsion-Type.....	370
Principle.....	504, 505	Transformer Copper Loss.....	246	Fibre-Tube.....	370, 372, 373, 375
Secondary Current Check.....	529	Transmission Circuit Per Mile.....	106	Film.....	509
Sub-Way Type.....	506	Underground		Fuse-Link Characteristic	
Vector Diagram.....	505	System.....	142, 143, 553 to 555	Curves.....	411, 412, 413
Constants, Watthour Meters.....	462, 463	CSP Distribution		Fuse-Link Standards.....	372 to 376
Contingency		Transformers.....	11, 17, 126, 201	K Type.....	373, 374
First.....	179, 188	Breaker Load Time		T Type.....	373, 374
Second.....	181, 188	Curve.....	244, 245, 400	Liquid Filled.....	376
Control Accuracy, Regulators.....	285, 286	Connection.....	239, 240	Open-Link Rating.....	372
Control, Street Lighting		Coordination.....	127, 397, 408	Repeater Fuse.....	376
Manual.....	516	Cost.....	221, 222		
Photo-Electric.....	516	Development.....	244	D.C. Network.....	149
Pilot Wire.....	517	Loading.....	244	D-C Network Calculator	
Time-Clock.....	517	Protective Link.....	127, 397, 400	Banked Secondary Planning.....	140
Control Voltage, Circuit Breaker.....	389	Signal-Light		Load Flow Studies.....	175 to 179
Conversion of Ohms		Operating Band.....	129, 130	Load Growth Studies.....	178, 179
to Percent.....	175, 214, 548	CSP Power Transformers.....	49, 263	Secondary Network	
Coordination		LTC.....	51	Planning.....	169, 175
DB Breakers With Fuses.....	418	Schematic Diagram.....	52	Short-Circuit Studies.....	175, 176
Fuses and Reclosers.....	410	Standard.....	51	De-Ion Arc Quencher.....	384
Loop Radial Primary Circuit.....	112	Tap Selection.....	51	Demand.....	22
Low Voltage Breakers and		CSPB Transformers.....	11, 139, 140, 202	Coincident.....	23, 27, 34
Ground Relays.....	421	Function.....	406, 407	Definition.....	22, 455
Power Fuse.....	392	Typical Installation.....	203	Diversified.....	23, 27, 34
Primary Fault Protection.....	123, 124	CSPH, Constant Current		Intervals of.....	455
Protective Link and		Transformers.....	506, 507	Maximum (See Also	
Secondary Breaker.....	127, 397, 400	Cumulative Demand Meters.....	456	Maximum Demand).....	23, 33
Regulating Equipment		Current Carrying Capacity, Conductors		Non-Coincident.....	23
Regulators and Fixed		ACSR.....	534	Recording Demand Meters.....	40
Capacitors.....	295 to 297	Aluminum.....	533	Demand Factor.....	24
Regulators and Switched		Copper.....	532	Demand Meters	
Capacitors.....	297, 298	Copper Welded.....	535	Advantage of Thermal Type.....	461
Step Regulators Applied		Current-Limiting Power		Combination Thermal Demand-	
in Series.....	295	Fuses.....	378 to 380, 393, 397	Watthour Type.....	460
Secondary Network Protective		Current Protected Transformer.....	203 to 205	Cost.....	461, 462, 463
Device.....	168	Current Transformers		Cumulative Type.....	456
Sectionalizing Fuse and		Accuracy Characteristics.....	482, 485	Impulse Operated, Indicating.....	469
Protective Link.....	409	Application.....	483	Indicating Type.....	456
Selective Tripping and Cascading.....	426	Burden.....	479	Integrated (Block Interval)	
Copper Conductors		Classification.....	471	Type.....	455, 456
Characteristics of.....	532	Continuous-Thermal-Current-		Cumulative—	
Current Carrying Capacity.....	532	Rating Factor.....	471	Demand Register.....	456, 459
Copper Welded Conductors.....	535	Definition.....	470	Indicating—	
Characteristics of.....	535	Determining Burden.....	490, 492	Demand Register.....	456, 459
Current Carrying Capacity.....	535	Dielectric Test.....	481, 482	KVA Type	
Cost		Equivalent Circuit.....	477	Type RI.....	461, 462
Demand Meters.....	461, 462, 463	Errors		Type RK.....	461, 462
Distribution—Substation.....	69 to 72	Phase Displacement.....	477, 478	Lagged (Exponential or Log-	
Distribution—Substation		Ratio Errors.....	477, 478	arithmetic) Type.....	455, 456
Power Transformers.....	106	Function.....	474	Demand Interval.....	458
Distribution		Impulse Level.....	481, 482	Mechanical Element.....	459
Transformers.....	128, 221, 222	Inverted Operation.....	493	Response	
Electricity.....	3	Metering Outfits.....	493	Characteristics.....	458, 459
Express Feeder in		Minimum Insulation Class.....	484	Thermal Element.....	459
Secondary Network.....	192	Phase-Angle Correction		Recording Type.....	455, 461
Network Capacitor.....	320	Factor.....	471, 478, 480, 484, 485, 489	Magnetic Tape.....	461
Operating Transformer.....	128	Polarity.....	490	Punched Tape.....	461
Outdoor Oil Circuit Breakers.....	106	Rated Current.....	471, 478	Test.....	463, 464
Primary Feeder.....	120, 121, 190, 192	Rated Voltage.....	471	Thermal Ampere Type.....	460
Primary Feeder in		Ratio Correction		Basic Circuit.....	460
Secondary Network.....	190 to 193	Factor.....	478, 480, 484, 485, 489	Vector Diagram.....	460
Primary vs Secondary		Secondary		Thermal Kilowatt Type	
Capacitors.....	318, 319	Open-Circuited.....	490, 492, 493	Basic Circuit Diagram.....	460
Secondary System.....	131	Standard Accuracy		Polyphase Use.....	460
Series Capacitors.....	269	Classes.....	478, 479, 480	Theory.....	460
Spot Network/Radial System.....	198, 199	Standard Ratios.....	478	Thermal KVA Type.....	460, 461

PAGE		PAGE
	De-Sensitive Relay.....	167
	Dielectric Tests	
	Capacitors.....	304
	Constant Current Transformers.....	506
	Current Transformers.....	481, 482
	Potential Transformers.....	475, 482
	Transformers.....	208, 210
	Disconnecting Switches—	
	Substation.....	48
	Distribution Substations— <i>Chapter 3</i>	
	Application Curve.....	74, 76, 77
	Application Curve,	
	Examples.....	82 to 84
	Automatic Service—Restoration..	54
	Bus Elaboration.....	50, 56
	Capacitor Banks.....	312
	Cost.....	69 to 72
	CSP (See <i>CSP Power Transformer</i>)	
	Disconnecting Switches.....	48
	Draw-Out Type Breakers.....	48
	Enclosure.....	67, 69
	Expansion Plans.....	72
	Load Areas.....	72 to 74
	System Changes at Constant	
	Load Density.....	79, 80
	System Changes with	
	Increasing Load	
	Density.....	80 to 82
	Feeder Circuit Breakers.....	48
	Function.....	1
	Fused Protection.....	393, 398, 399
	Grounding Switch.....	393
	High-Voltage Switching.....	48
	Load Tap Changing.....	48
	Mobile (See Also	
	<i>Mobile Substations</i>).....	47, 57
	Multiple Transformer.....	53
	Noise.....	69
	Normal and Emergency	
	Supply.....	52, 53
	Overcurrent Relay.....	48
	Primary Network.....	117
	Protective Link.....	49
	Rating Selection.....	72
	Ratio of Load to Capacity.....	84, 85
	Spot Network.....	56
	Standardization (See	
	<i>NEMA Standards</i>)	
	Structure.....	64, 65
	Transformers.....	47, 48
	Types.....	5, 7, 8
	Underground Subtransmission.....	66
	Unit—Substation.....	48
	Unit—Substation Ratings.....	61, 62
	Voltage Ratings.....	250
	Voltage Regulation (See Also	
	<i>Substation Voltage</i>	
	<i>Regulation</i>).....	48, 257, 258, 271 to 275
	Distribution System	
	Distribution Substation (See	
	<i>Distribution Substations</i>)	
	Economics.....	17
	Functional Classification.....	1, 5
	Functional Components.....	1
	Primary.....	7 to 11, 109 to 125
	(See Also <i>Primary</i>	
	<i>Distribution System</i>)	
	Quality of Service.....	5
	Secondary.....	11 to 14, 125 to 147
	(See Also <i>Secondary</i>	
	<i>Distribution System</i>)	
	Subtransmission.....	5 to 7
	(See Also <i>Subtransmission</i>	
	<i>System</i>)	
	Distribution System	
	Subtransmission (continued)	
	Types	
	Network.....	5
	Radial.....	4, 5
	Underground.....	15, 16, 142 to 146
	Voltages.....	14, 250
	Distribution Transformers (See	
	<i>Transformers</i>)	
	Diversified Demand.....	3, 4, 23, 27, 41
	Diversity Factor	
	Application.....	35 to 38
	Definition.....	25
	Load Estimation.....	42, 43
	Dry-Type, Network Transformer	
	Sealed.....	156
	Ventilated.....	155, 158
	Duplex Transformer.....	230, 231
	Economics	
	Banked Secondary.....	133, 134
	Capacitors—General.....	309, 310
	Capacitors, Primary vs-	
	Secondary.....	318, 319
	Capacitors, Secondary Network.....	320
	Distribution System.....	17
	Distribution Transformer	
	Loading.....	128, 129
	Distribution Transformer—	
	Secondary Combination.....	130
	Higher Secondary	
	Voltage.....	125, 136, 188 to 190
	Network Transformer Rating	
	and Spacing.....	193
	Primary Network.....	117
	Secondary Circuit.....	130
	Secondary Network	
	System.....	188 to 190
	Street Lighting.....	526 to 530
	Subtransmission.....	103 to 107
	Underground Distribution System.....	143
	Eddy Current.....	429
	Electric Furnace	
	Power Supply Oscillograms.....	351
	Voltage Flicker.....	350
	Electric Welders	
	Types.....	355
	Voltage Flicker.....	355
	Electromagnet, Watthour	
	Meter.....	428, 429, 430
	Electronic Equipment—	
	Voltage Effect.....	253
	Enclosure, Substation.....	67, 69
	Equivalent Circuits	
	Autotransformer.....	549, 550
	Balanced Three-Phase Transformer	
	Negative Sequence.....	224, 225
	Positive	
	Sequence.....	224, 225, 549, 550
	Zero Sequence.....	224, 225, 549, 550
	Current Transformers.....	447
	Potential Transformers.....	472
	Single-Phase Transformers	
	Schematic	
	Representation.....	210, 211
	Series-Multiple	
	Secondaries.....	222, 223
	Three-Multiple	
	Secondaries.....	222, 223
	Two-Winding.....	222, 223
	Errors, Metering	
	Current Transformers.....	478 to 480
	Potential Transformers.....	472, 473
	Express Primary Feeders.....	110, 111
	Expulsion Type Devices	
	Cutouts.....	370
	Lightning Arresters.....	201, 202
	Power Fuses.....	377
	Fault Current	
	Banked Secondaries.....	138, 406, 407
	Definition.....	365
	Secondary Network Mains.....	151 to 153
	Studies by D-C Board.....	177
	Shunt Capacitor Banks.....	329
	Fault Protection	
	Banked	
	Secondaries.....	138, 139, 406, 407
	Distribution Transformers.....	393, 397
	Primary Feeders.....	109, 112, 123
	Primary Network.....	113, 114, 116
	Primary Shunt Capacitors.....	317
	Secondary Network.....	151, 153, 188
	Secondary Shunt Capacitors.....	319
	Series Capacitors.....	339, 340
	Street Lighting.....	510, 511, 515
	Substation Bus.....	56
	Underground, Residential.....	144
	Faults	
	Burning Clear in Banked	
	Secondaries.....	138, 139, 406, 407
	Burning Clear in Secondary	
	Networks.....	151 to 153, 182
	Causes.....	366
	Conductor Burndown.....	367 to 368, 371
	Data.....	366, 367
	Nature	
	Non-Persistent	
	(Temporary).....	123, 367
	Persistent (Permanent).....	123, 367
	Rates.....	367
	Services.....	135
	Types.....	366
	Feeders (See <i>Primary Distribution</i>	
	<i>System</i>)	
	Feeder Breakers	
	(See Also <i>Circuit Breakers</i>)	
	Loop Radial Primary.....	112
	Primary Network.....	114
	Tie.....	112
	Feeder Losses (See <i>Losses</i>)	
	Ferroresonance.....	341, 342, 358
	Field Measurements.....	39
	Maximum Demand Test.....	39, 40
	Recorded Demand.....	40
	Spot Check.....	39
	Filament Lamps (See <i>Incandescent</i>	
	<i>Lamp</i>)	
	Film Cutout, Street Lighting.....	509
	Fixed Charges, Annual:	
	Street Lighting.....	527, 528, 529
	Fixed Shunt Capacitors	
	Coordination with	
	Regulators.....	295 to 297
	(See Also <i>Shunt Capacitors</i>)	
	Flexibility for Load Growth	
	Banked Secondaries.....	139
	Primary Network.....	116
	Secondary Network.....	178, 179
	Underground System.....	143
	Flicker— <i>Chapter 9</i>	
	Crusher Motors—Series	
	Capacitor Application.....	357, 358
	Cyclic Loads.....	353
	Effect of Momentary	
	Interruptions on	
	Induction Motors.....	362, 363
	Synchronous Motors.....	363

	PAGE		PAGE		PAGE
Flicker (continued)		Fuse, Power (continued)		Incandescent Lamp (Filament Lamp)	
Effect of Voltage Dips on		Characteristics of	377	Characteristic Curve	497, 498
Mercury Lamp	362	Classification of	372	Cost Study	526 to 530
Motor Contactor	362	Current Limiting		Efficiency	497
Effect Upon Utilization		(BAL)	378, 379, 380, 393, 397	Life	497
Equipment	361 to 363	Definition	369, 370	Maintenance	525, 526
Electric Furnace	350	E Rated	377	Required KW Data	519
Current Swing	352	Expulsion	377	Voltage Effect	251, 497
Electrical Characteristics	352	Fibre Tube	377	Indicating Demand Meters	456
Graphic Charts	351	Liquid-Filled	380	Induction Motors	
Impedance Distribution	352	Ratings	377	Momentary Service	
Mutual Drop Coefficient	352, 353	Super Surge	397, 402, 403	Interruption	362, 363
Oscillograms at Starting	351	Fuses, Application		Shunt Capacitor Application	322
Electric Shovels	355 to 357	Banked Secondary	406, 407	Sub-Synchronous Resonance	340, 341
Improved Excitation	355, 356	Capacitor	327, 328, 397, 401, 404 to 406	Voltage Effect	253, 254
Mag-A-Stat Regulator	357	Group Fusing	404, 405	Induction Regulators	267, 268
Mathematical		Individual Fusing	405	Band Width	283
Analysis	355 to 357	Coordination	392, 409	Control Circuit	281
Regulator Application	356	Current Rating Consideration	392	Phase Shift	268
Supplying System	355	Distribution Transformers		Single-Core Type	268
Synchronous Condenser		393, 397 to 399, 402, 403	Triplex Type	268
Application	356	Fusing Ratio	397	Inductive Reactance Spacing Factor	546
Electric Welders	355	Indoor	393	Industrial Feeders—	
Furnace Transformer	353	Interrupting Capacity		Voltage Drop	256, 257
Intermittent Loads	350	Determination	392	Industrial Shunt Capacitor	
Light—Commercial Area	133, 134	Network Protectors	167	Application	320 to 322
Motor Starting	133, 348, 350	Outdoor	393	Inrush Current	
Permissible Limits	345 to 347	Potential Transformers	397, 401	Motors	363
Comparison Among Utilities	347	Primary Feeder		Shunt Capacitors	331 to 334
Survey of Limit	346	Sectionalizing	113, 123, 407, 408	Instantaneous Power	20
Tungsten Filament		Protected Fuses	407, 408, 409	Instrument Transformer Correction	
Lamp	345, 346	Protecting Fuses	407, 408, 409	Factor	471, 480, 485, 486, 487
Reciprocating Loads	350	Shunt Capacitors	327	Current	478, 479
Reduction by Series		Substations	393	Potential	471, 473, 474
Capacitors	338, 339, 350, 354, 357	Time Current		Instrument Transformers	
Remedial Measures		Characteristics	394 to 396	Accuracy Burden Rating	470
Comparison Chart	361	Generator Voltage Regulators	263	Burden	470
Electronic Voltage		Graded Insulation	239	Classification	471, 472
Regulator	356	Grid		Correction	
Series Capacitors	354, 357	Secondary Network	150, 174	Factor	471, 480, 485, 486, 487
Synchronous Condensers	354	Subtransmission	88	Definition	470
Residential Area	133	Grounding—Series Street		Functions	471
Rolling Mills	358 to 361	Lighting	511, 512	Metering Outfits	493
Four-Stand Tandem Cold		Grounding Switch	393	Transformers—	
Mills	360	Harmonic Voltage—Shunt		Current, (See <i>Current Transformers</i>)	
Hot-Strip Mills	359, 360	Capacitor Applications	334	Potential (See <i>Potential Transformers</i>)	
Load Characteristics	358, 359	Higher Primary Voltage	117, 260	Insulation Coordination	
Plate and Blooming		Higher Secondary Voltage	125, 136	Basic Impulse Level	210
Mills	359, 360	Economic Study—Residential	136	Reduced Insulation Level	210, 211
Plate Mills	359, 360	Economic Study—		Integrated Demand Meters	455, 456, 459
Transient Electrical Swings	360	Secondary Network	188 to 190	Interlacing of Network Feeders	169
System Impedance	354	Typical Services	137	Interlocking, Substation Breakers	48
Fluorescent Lamps		High-Voltage Switch	156, 182	International Candle	495
Ballast	501, 514	High Voltage Switching—		Interrupting Duty	384
Construction	501	Distribution Substation	48	Circuit Breakers	384, 388
Cost Study	526 to 530	Impedance		Circuit Reclosers	381
Electrode	501	Conversion of Ohms		KWHR Meters— <i>Chapter 11</i>	
Life	501, 514	to Percent	175, 214, 548	KVA Demand Meters	461, 462, 463
Lumen Maintenance Curve	501	Constant Current Transformers	506	Lagged Demand Meters	455, 456, 458, 459
Required Transformer		Distribution		Lamp Flicker (See <i>Flicker</i>)	
Capacity	520, 521	Transformers	206, 214, 215, 216	Lamp Life	
Voltage Effects	252, 502	Network Transformers		Fluorescent Lamps	501
Fluorescent-Mercury Lamps	500, 501	Overhead	187	Incandescent Lamps	497
Foot Candle		Underground	216, 217	Life Testing—Transformers	244
General	495	Impulse Strength		Lightning Arrester	
Recommended Values	496	Bushing, Transformer	210, 211	Application Data	556
Footlambert	495	Current Transformers	481, 482	Expulsion Type	201, 202
Fuse Links		Distribution Transformers	210	LVT, LXT Type	511
Melting Current	374	Potential Transformers	473, 475, 482	Lightning Protection	
Standards	372 to 376	Impulse Totalizing, Metering	466 to 468	Application Data	556
Time-Current					
Characteristics	376, 411, 412, 413				
Fuse, Power					
Boric Acid	377, 378, 379, 398, 399				

PAGE		PAGE		PAGE
	Lightning Protection (continued)		Maximum Diversified Demand	
	CSP Transformer.....201		(continued)	
	CSPB Transformer.....202		Equation.....34	
	Distribution Transformer.....127		Residential Loads.....36	
	Network Transformers.....156		Measurements (See <i>Field Measurements</i>)	
	Secondary Circuit.....130		Mercury Lamp	
	Semi-buried Type		Ballasts.....498, 501, 514	
	Transformers.....144, 145		Characteristics.....499	
	Series Street Lighting.....511		Cost Study.....526 to 530	
	Line Drop Compensation.....287 to 294		Electrode.....498	
	Setting, General.....288		Lumen Maintenance Curve.....500	
	Example.....288 to 290		Required Transformer	
	Settings		Capacity.....520, 521	
	Bus Regulators.....293		Starting.....498, 499	
	Overcompensation.....293, 294		Voltage Effect.....252, 362, 499	
	Three-Phase Regulators.....290		Metering Outfits.....493	
	Three, Single-Phase,		Metering, Principles & Practices—	
	Closed-Delta.....292		<i>Chapter 11</i>427	
	Three, Single-Phase,		Metering, Special Compensators.....465	
	Wye.....290 to 292		Impulse Operated Demand Meter.....469	
	Two, Single-Phase,		Impulse Totalizing.....466 to 468	
	Open-Delta.....290		Data Transmission Circuit.....467	
	Theory.....287		Diagram.....467	
	Line Drop Compensator.....263, 281, 287		WA Totalizing Relay.....468	
	Line Sectionalizer, Automatic.....382, 383		WD Impulse Difference	
	Application.....113, 114, 122, 123, 417		Relay.....468	
	Ratings.....383		WRA Impulse Recorder.....467, 468	
	Sequence-of Operation.....382		WRI Kva Receiver.....468	
	Line Sectionalizing.....122 to 124		WS Impulse Storage Relay.....468	
	(See Also <i>Line Sectionalizer</i>)		Load Survey Recorders	
	Limiters—Secondary		Arrangements.....470	
	Network.....152, 153, 173, 177, 182		Magnetic Tape Record.....469	
	Load Characteristics, Application to		Punched Card.....469, 471	
	System Design.....33 to 38		Loss.....465	
	Diversity Factor.....35 to 38		Off-Peak Water Heater.....464, 465	
	General.....33		Remote.....465 to 468	
	Loss Evaluation.....38		Telemetering.....467	
	Maximum Demand.....33, 34		Totalizing	
	Maximum Diversified Demand.....34, 35		Electrical Totalization.....466, 467	
	Load Characteristics,		Meaning of.....466	
	Determination.....38 to 43		Mechanical Totalization.....466	
	Estimation—		Mid-Tie Breaker.....114	
	Coincidence Factor.....42, 43		Mobile Substation.....7, 57	
	Conversion Factor.....42		Application.....57	
	Diversified Demand Method.....41		Standards.....57	
	Diversity Factor.....42, 43		Transformers.....57	
	Maximum Demand and		Weight & Dimensions.....57, 58	
	KWH.....41 to 43		Motor Contactors—Voltage Dip.....362	
	Transformer Loading.....41		Motor Hunting, Series Capacitor.....342	
	Field Measurements.....39		Motor Starting—Flicker.....43, 348 to 350	
	Maximum Demand Test.....39, 40		Banked Secondary Systems.....141	
	Recorded Demand.....40		Starting Characteristics.....349	
	Spot Check.....39		Starting Currents.....43, 44	
	Quantities Required.....39		Motor Starting—Sub-Synchronous	
	Load Density		Resonance.....340, 341	
	Area Coverage.....30		Negative Sequence Circuit,	
	Banked Secondary Applications.....138		Transformer.....224, 225	
	Linear Coverage.....30		NEMA Standards	
	Measurement.....3		Articulated Primary Unit	
	Range of.....4		Substations.....59, 60, 61	
	Secondary Network Applications.....182		Bushings, Distribution	
	Load Diversity		Transformers.....210, 211	
	Definition.....25		Capacitor Case Rupture	
	Hourly Variation Factors.....37		Curve.....327, 328	
	Load Diversion—Secondary		Capacitor Switching Device.....322	
	Network.....175, 186		Clearances and Insulation,	
	Load Factor		Substations.....63, 64	
	Distribution Transformer.....128		Distribution Cutouts.....375	
	General.....24, 25		Duplex Substation.....62	
	Load Growth.....31, 32		Integral Primary Unit	
	Load Growth—Graphs		Substations.....62	
	Energy Sales.....2		Low-Voltage Selective Substations.....61	
	Number of Customers.....2		Meter Ratings.....434	
	Revenue.....3			
	Load Growth on			
	Banked Secondaries.....139			
	Distribution Substations.....72			
	Distribution Transformers.....129			
	Secondary Networks.....178, 179			
	Spot Loads.....188, 189			
	Load Survey Recorders.....468 to 471			
	Load Tap Changer			
	(L T C).....48, 257, 258, 263			
	CSP Transformer.....51, 263			
	Sequence of Operation.....264			
	URS.....263, 264			
	Loading on			
	Constant Current Transformers.....506			
	Distribution Substations.....84, 85			
	Distribution			
	Transformers.....127, 128, 241			
	Duplex Transformers.....231			
	Network Transformers.....170, 173			
	Primary Feeders.....120, 121			
	Secondary Banking.....140			
	Spot Network			
	Transformers.....184, 194, 195			
	Loads			
	Balanced.....29			
	Characteristics (See <i>Load</i>			
	<i>Characteristics</i>)			
	Classification.....2, 19, 20			
	Density.....3, 4, 29			
	Estimating.....40 to 43			
	Spot.....177			
	Loop-Type Primary Feeder.....112, 113			
	(See Also <i>Primary Distribution</i>			
	<i>System</i>)			
	Loop-Type Subtransmission			
	Circuits.....87, 88			
	Loss			
	Cable, Street Lighting.....519			
	Constant Current Transformers.....506			
	Core.....216, 217			
	Evaluation.....38			
	Load.....214, 215, 216			
	Metering.....465			
	Reduction by Shunt			
	Capacitors.....310, 315 to 317			
	Transformer.....245			
	Loss Factor.....27, 38, 245			
	Curves.....28			
	Definition.....27			
	Equivalent Hours.....28			
	Loss Ratio, Transformer.....218			
	Losses in Primary Networks.....116			
	Losses in Subtransmission			
	Circuits.....95 to 98			
	Lumen.....495			
	MAGAMP, Regulator Control.....282			
	Main Secondary Breakers.....425			
	Maintenance			
	Primary System.....119, 120			
	Street Lighting.....524 to 526			
	Master Relay, Network			
	Protector.....160 to 164			
	Maximum Demand.....23, 33, 455			
	Application.....33, 34			
	Equation.....34			
	Measurement.....24			
	Relationship with KWHR			
	Consumption.....41			
	Test.....39, 40			
	Time Period.....455			
	Maximum Diversified Demand.....34			
	Application.....34, 35			
	Basic Characteristics.....35			

	PAGE		PAGE		PAGE
NEMA Standards (continued)		Oil Switches,		Potential Transformers (continued)	
Molded-Case Circuit Breakers . . .	383	Street Lighting	507, 509, 513	Service Conditions, Affecting Errors	
Power Fuses	377	Operating Cost, Annual		Burden	474
Power Switching Equipment	63	Distribution Transformers	128	Frequency	474
Primary Network Substation	61	Street Lighting	527, 528, 529	Temperature	474
Radial Primary Substation	59	Outages, Secondary Network Feeders .	179	Voltage	474
Rating, Distribution		Overcompensation, L.D.C.	293, 294	Standard Burden	473, 477
Transformers	210, 212, 213, 214	Overcurrent Condition, Definition . . .	365	Thermal Burden Rating	470
Secondary Network Protectors	159, 160	Overhead Secondary Network		Transformer Correction	
Secondary Network Transformer	154	(See <i>Secondary Network</i>)		Factor	471, 473, 474
Secondary Voltage Levels	125	Overload Characteristics,		Vector Diagram	472
Short Circuit Capability,		Transformer	241	Power	20
Transformer	205, 206	Overvoltage Protection, Shunt		Active	21
Spot Network Substation	61	Capacitors	329 to 331	Apparent	20, 21
Voltage Ranges	249	Parallel Conductors in Secondary		Average Phasor	22
Network Calculator, Planning a		Network	152	Instantaneous	20
Secondary Network	175	Parallel Operation, Transformers	224	Phase	22
Network Protectors		Permanent Magnet, Watthour Meter .	430	Reactive	22
Classification of Insulating		Permissible Limits		Power Capacitors (See <i>Shunt and</i>	
Material	160	Flicker	345 to 347	<i>Series Capacitors</i>)	
Continuous-Current Rating	162	Voltage	247, 250	Construction	303
Coordination of Master and		Phase-Angle Correction Factor		Dielectric Test	304
Phasing Relay	165, 166	Current Transformers	471, 478, 480, 484, 485, 489	Overvoltage Limit	304
De-Sensitizing Relay	167	Potential		Rating	303, 304
Dielectric Test Voltage	161	Transformers	473, 484, 485, 488	Standards	303, 304
Functions	156 to 159	Phase Power	22	Transient Voltage and	
Fuses	167	Phase-Shifting		Current Limit	304
Master Relay		Transformers	455, 456, 457	Power Circuit Breakers	389
Adjustments	160	Accuracy Tests	456	(See Also <i>Circuit Breakers</i>)	
Closing Characteristics	160, 163	Application Chart	456	Power Factor	
Opening		Type K-1	455	Average	455
Characteristics	162, 163, 164	Type K-5	455, 458	Definition	28
Overhead Applications	182, 184, 185	Wiring Diagrams	457, 458	Primary Feeder	122
Phasing Relay	164, 165	Phasing Relay	164, 165	Power Fuse (See <i>Fuse</i>)	
Pumping Action	166, 167	Phasors, Scalar or Dot Product,		Power System Components,	
Rating, Current and Voltage	160	Watthour Meter	434, 435	One-Line Diagram	47
Standard Ratings	162	Planning the		Primary Distribution System	
Standards, NEMA	159, 160	Banked Secondary		Area Coverage Principle	119
Temperature-Rise Limit	162	System	140 to 142	Balancing Load	258
Network Transformer	154, 171, 173, 204	Distribution Substations	72 to 85	Circuit Mileage	120
Askarel Filled	155, 205	Light-Duty Secondary Network	185	Cost	120, 121
Comparison Between Conventional		Secondary Network	171 to 181	Design	78
and Space-Miser Design	157	Positive Sequence Circuit,		Fault Protection	123
Impedance	216, 217	Transformer	224, 225	Feeder Circuit Patterns	72
Lightning Protection	156	Potential Transformers		For Secondary Network,	
Loading	170, 173	Accuracy Characteristics	482, 485	Overhead	183, 185, 188
Oil-Filled	154, 157, 205	Accuracy Classes, Standard	473, 474	For Secondary Network,	
Overhead		Application	483	Underground	168, 171, 172, 174, 256, 257
Applications	182, 184, 185, 186	Burden	472, 473, 477	Function of	1
Sealed-Dry Type	156, 159, 205	Classification	471	Fuse Application	123, 407
Underground Applications	153, 154	Definition	470	Hot-Line Maintenance	119
Ventilated Dry Type	155, 158, 205	Determining Burden	485, 491	Industrial Feeders	256, 257
Networks	5	Dielectric Tests	475, 482	Loading	120, 121
D-C	149	Equivalent Circuit	472	Loop-Radial Circuit	9, 112, 113
Heavy-Duty	183, 184	Errors	472, 473	Breaker Coordination	112
Light-Duty	184 to 188	Impulse Level	473, 475, 482	Fuses	113
Medium-Duty	183, 184	Limit of Ratio Correction Factors		Loop-Tie Breaker	112
Overhead		and Phase-Angle	473, 474	Protective Devices	112
Secondary (See <i>Secondary Network</i>)		Marked Ratio, Standard	475	Reclosers	113, 380, 381, 410, 414 to 417
Primary	10, 113 to 117	Metering Outfits	493	Sectionalizers	113, 382, 383
(See Also <i>Primary Network</i>)		Neutral Inversion	490	Voltage Regulation	112
Secondary	13	Overvoltages	490	Primary Network	
(See Also <i>Secondary Network</i>)		Phase-Angle Correction		(See <i>Primary Network</i>)	
Spot	14	Factor	473, 484, 485, 488	Sectionalizing	122, 123, 407, 408
(See Also <i>Spot Network</i>)		Polarity	490	Series Capacitor Application	337, 338
Underground		Primary Connections	473, 476	Service Reliability	109
Secondary (See <i>Secondary Network</i>)		Protection	397	Shunt Capacitor Use	122
Neutral Inversion	235, 236, 490	Quarter Thermal Burden		Straight-Radial Circuit 8, 9, 109 to	
Noise, Substation	69	Ambient Temperature	470	Express Feeders	9, 110, 111
No-Load Losses, Transformer	216, 217	Rated Voltage	470, 473, 475	Fault Isolation	109, 110
Non-Coincident Demand	23	Ratio Correction		Phase-Area Plan	111
Off-Peak Water Heater Load,		Factor	472, 483, 484, 485, 488		
Metering	464, 465				

PAGE		PAGE		PAGE	
	Primary Distribution System		Regulation (continued)		Secondary Mains
	Straight-Radial Circuit (continued)		Design Voltage Limit.....14, 250		Interconnected Grid.....150, 151
	Protective Devices.....109		Distribution System.....14, 250		Limiters.....152, 153, 173, 182
	Tie Circuits.....10, 109		Distribution Transformer.....218		Parallel Conductors.....152
	Voltage Regulation.....111		Effect on Watthour Meter.....432		Secondary Networks
	Underground, Residential.....144		Individual Feeder.....122, 273		Overhead.....182, 184, 186
	Voltage Drop.....255, 256		Methods of Improvement.257 to 262		Underground.....151, 174
	Voltage Levels.....8, 116, 117		Primary Feeders.....14, 111, 112		Voltage Drop.....151, 255
	Voltage Regulation.111, 112, 122, 273		Primary Network.....116		Secondary Networks, Overhead
	Voltage-Square Rule.....118		Secondary System.....130		Aerial Cable Application.....183
	(See Also <i>Voltage Drop</i>)		Substation.....48, 271		Burning Clear.....182
	Primary Network.....10, 113 to 117		Supplementary.....278		Correlation of Transformers and
	Economics.....117		Regulators (See <i>Voltage Regulators</i>)		Secondary Mains.....184
	Fault Protection...10, 113, 114, 116		Reignition, Capacitor Switching.....322		Heavy-Duty.....183, 184
	Flexibility.....116		Relay		High-Voltage Switch.....182
	History of.....113		MR Multiple....513, 514, 515, 516		Light-Duty.....184 to 188
	Losses.....116		Overcurrent.....48		Limiters.....182
	Mid-Tie Breaker.....114		PC Protective,		Load Density Range.....182
	Network Substations...113, 116, 117		Street Lighting.....510, 511		Load Determination.....185
	Primary Feeders.....117		Reclosing Relay.....123		Load Division.....186
	Relaying.....114, 116		Secondary Network Relays		Medium-Duty.....183, 184
	Service Reliability.....116		De-Sensitizing Relay.....167		Network Protectors...182, 184, 185
	Subtransmission Circuits...115, 117		Master Relay.....160 to 164		Planning (See Also
	Transformer Breaker.....113		Phasing Relay.....164, 165		<i>Network Protectors</i>).....171
	Typical Arrangement...113, 114, 115		SR Series Multiple.....515, 516		(See Also <i>Planning, Secondary</i>
	Voltage Control.....298, 299		Time Delay.....283 to 285		<i>Networks U.G.</i>)
	Voltage Regulation.....116		Voltage Regulating,		Primary Feeders.....183, 185, 188
	Voltages.....11, 113, 115		Regulators.....281 to 283		Secondary Mains.....182, 184, 186
	Protective Devices		Relaying		Spot Loads (See <i>Spot Networks</i>)
	Automatic Circuit Reclosers		Primary Network.....114, 116		Transformers.....182, 184, 185
	(See <i>Circuit Reclosers</i>)		Secondary Network.....160 to 168		Connections.....187, 188
	Automatic Line Sectionalizers		(See Also <i>Network Protectors</i>)		Impedances.....187
	(See <i>Line Sectionalizers</i>)		Series Capacitors Applications...340		Protection.....188
	Circuit Breakers		Remote Metering.....466 to 468		Rating.....185, 186
	(See <i>Circuit Breakers</i>)		Repeater Fuses.....376		Spacing.....185, 186
	Distribution Cutouts (See <i>Cutouts</i>)		Residential Feeders, Voltage...254 to 256		Voltage Level.....187
	Fuses, Classification.....372		(See Also <i>Primary Distribution System</i>)		Secondary Network Underground (See
	Power Fuses (See <i>Fuse</i>)		Resonant Effects,		Also <i>Spot Network</i>)
	Protective Link		Shunt Capacitors.....334 to 336		Application Factor.....168 to 171
	Characteristic.....397, 400		Restrike, Capacitor Switching.....322		Burning Faults Clear.....151 to 153
	Coordination with Sectionalizing		Rural Feeders, Voltage Drop...255 to 257		Cables, Current Carrying
	Fuse.....409		(See Also <i>Primary Distribution System</i>)		Capacity.....174
	CSP Transformer.....127		Secondary Distribution System		Capacitor Application.....319, 320
	Distribution Substation.....49		Aerial Cable.....130		Contingency.....179 to 181
	Protectors, Network		Banking.....137		Costs.....190, 191
	(See <i>Network Protectors</i>)		(See <i>Banked Secondary System</i>)		D-C.....149
	Pumping Action		Distribution Transformers (See		D-C Calculator Use.....175
	Network Protector.....166, 167		<i>Transformer</i>)		Combining Loads.....173
	Switched Capacitors.....287		Flicker		Contingency Studies...179 to 181
	Radial Distribution		In Commercial Area...133, 134		Impedance Conversion.....175
	(See Also <i>Primary Distribution System</i>)		In Residential Area.....133		Load-Flow Studies...175 to 179
	Definition.....4, 5		Function of.....1, 125		Load-Growth Studies...178, 179
	Primary Feeder.....8, 109 to 112		Higher Voltage.....125, 136		Short-Circuit Studies...175, 176
	Subtransmission.....87		(See Also <i>Higher Secondary Volt-</i>		System Representation...175
	Ratio Correction Factor		<i>age</i>)		Description, General.....12, 150
	Current Transformers...478, 480,		Lightning Protection.....130		Early Systems.....149
	484, 485, 489		Meter, KWH.....136		Feeder Outage Probability 179 to 181
	Potential Transformers...472, 483,		Motor Starting Voltage Drop...133		High-Voltage Switch.....156
	484, 485, 488		Network (See <i>Secondary Network</i>)		Higher Secondary
	RCOC Oil Switch.....507, 509		One-Line Diagram.....125		Voltages.....188 to 190
	Reactive Power.....22		Secondary Racks.....129		Interlacing of Supply Circuits.169,
	Reclosers (See <i>Circuit Reclosers</i>)		Services.....134, 135, 136		170
	Reclosing Relay.....123		(See Also <i>Services</i>)		Limiters.....151, 153, 173, 182
	Recording Demand Meters.....455, 461		Transformer-Secondary		Load to Transformers,
	Advantage.....40		Combination.....130		Capacity Ratio.....173
	Application.....40		Voltage.....125, 126, 151		Modern Trends.....188
	Load Survey Recorder.....40		Voltage Drop, Permissible...255, 256		Network Unit.....153
	Reduced Insulation.....210, 211		Voltage Regulation...130 to 132,		Parallel Conductors Per Phase 151,
	Reflection Factor.....496		134, 255, 256		152
	Register, Metering.....428, 429, 431, 432		Secondary Faults, Burning Clear		Planning.....171 to 181, 189, 190
	Regulation		Banked Secondaries...138, 139,		Data Required for.....172
	Bus.....122		406, 407		Economic System...189 to 191
	Definition.....248		Secondary Network...151 to 153, 182		Feeder Outage—
					Contingency.....179 to 181

PAGE		PAGE		PAGE	
	Secondary Network, Underground		Services (continued)		Shunt Capacitors (continued)
	Planning (continued)		Function..... 1		Voltage Rise..... 261, 306, 307, 310
	Load Estimation..... 172		Higher Secondary Voltage..... 137		Spot-Check, Load Measurement..... 39
	Power Source..... 172		Underground, Residential..... 146		Spot Loads..... 177, 188, 189
	Preliminary Design..... 173		Voltage Drop		Spot Networks
	Primary Feeders..... 172, 174		Permissible..... 135		Advantages..... 183
	Secondary Mains..... 174		Residential Area..... 255		Cost..... 190, 194, 195, 197
	Transformer Rating and		Rural Area..... 255, 256		General Description..... 14, 183
	Spacing..... 193		Shunt Capacitive Reactance		Loading Transformer Curves,
	Primary Feeders..... 167		Spacing Factor..... 547		Permissible..... 196
	Costs..... 190 to 193		Shunt Capacitors		Load to Transformers.. 184, 194, 195
	Express Feeder..... 192		Connections..... 327 to 329		Mutual Support of
	Interlacing..... 168 to 171, 193		Construction..... 303		Adjacent..... 195, 197
	Planning..... 172, 174, 189		Coordination with Voltage		Network Unit Cost..... 195, 197
	Voltage Control..... 299		Regulators..... 295 to 297		Primary Feeder Supply..... 195, 197
	Voltage Level..... 171		Economic benefits, Evaluation.. 311		Spot Network/
	Protective Device		Factory Tests..... 304		Radial System Economy.. 198, 199
	Coordination..... 168, 169		Failure Probability..... 328, 404, 405		Substation..... 56
	Protectors (See <i>Network Protectors</i>)		Fault Currents in		Spot Network/Radial System..... 198
	Relaying..... 160 to 168		Large Banks..... 314, 315		Cost..... 190, 197
	Secondary Grid or Mains 150, 151, 174		Function..... 304, 305		Description..... 198
	Burning Faults Clear... 151, 152		Harmonic Voltages..... 334		Economics..... 198, 199
	Cable, Types..... 151		High-Voltage Applications 312 to 315		(See Also <i>Spot Networks</i>)
	Conductor Sizes..... 151		Fault Currents..... 314, 315		Standards (See Also <i>NEMA Standards</i>)
	Current Carrying Capacity		Overvoltage During Faults.. 314		IPCEA (Insulated Power Cable
	of Cable..... 174		Protection..... 313		Engineer's Association)..... 145
	Limiters..... 152		Switching Devices..... 322		Power Capacitors..... 303, 304
	Parallel Conductors Per		Induction Motor Applications.. 322		Service Continuity..... 32
	Phase..... 151, 152		Industrial Plant Application.... 320		Substation..... 59 to 62
	Voltage Regulation..... 151		Location..... 320, 321		Voltage Rating..... 32
	Spot Loads..... 177, 189		Rates, Effect of..... 321, 322		Starting Current, Motor
	(See Also <i>Spot Networks</i>)		Inrush Current..... 331 to 334		Central Air Conditioners..... 44
	Transformer Rating and Spacing 193		Loss Reduction by Use of 306, 310,		Motor Driven Domestic
	Transformers.. 153 to 157, 171, 173		315 to 317		Appliances..... 43
	(See Also <i>Network Transformers</i>)		Network, Secondary..... 319		Residential Heat Pumps..... 44
	Voltage Control,		Overvoltage During Faults..... 314		Room Air Conditioners..... 44
	Network Feeders..... 299		Overvoltage Limit..... 304		Steel Rolling Mill—
	Voltage Levels..... 151, 188 to 190		Primary Feeder Application... 122,		Power Demand..... 358, 359
	Secondary Racks..... 129		261, 315 to 318		Step-Type Regulator..... 264 to 267
	Sectionalizer (See <i>Line Sectionalizer</i>)		Bank Ratings..... 315		Band Width..... 282, 283
	Self-Supporting Cable..... 135, 136		Fault Protection..... 317		Characteristics..... 268
	Semi-buried Type Transformer		Location, Two-Thirds		Control Circuit..... 281
	Installations..... 144, 145, 204, 205		Rule..... 316, 317		Coordination with Regulator
	Series Capacitors		Loss Reduction..... 315 to 317		and Shunt Capacitors.. 295 to 298
	Application		Switched Banks..... 268, 317		Cost..... 274
	Subtransmission..... 336, 337		Protection..... 327 to 331		Distribution Type..... 266
	Primary Feeder..... 337, 338		Delta-Connected Banks..... 404		Schematic Diagram..... 267
	Application Consideration.. 335, 336		Fused..... 327, 328, 397,		Standard Rating..... 274
	Arc Furnace Correction..... 354		401, 404 to 406		Station Type..... 265
	Cost Comparison..... 269		Group Fusing..... 404, 405		Survey, Time Delay..... 284
	Crusher Motor Correction..... 358		Individual Fusing..... 404, 405		Tap Changer Connection..... 265
	Ferroresonance..... 341, 342, 358		Individual Unit..... 329		Tap Changing Mechanism..... 267
	Lamp Flicker..... 338, 339		Overcurrent..... 329		Time-Delay Relay..... 284
	Motors Hunting..... 342		Overvoltage..... 329 to 331		Street Lighting <i>Chapt. 12</i> 495
	Protection		Surge..... 329		Absorption Factor..... 496
	Dielectric Failure..... 340		Wye-Connected Banks.. 404, 405		Brightness..... 495
	Line Fault..... 339		Ratings..... 303, 304		Candle Power..... 495
	Overload..... 339		Released KVA Capacity..... 309		Cleaning of Lamps..... 524
	Rating, Determination		Resonant Effects..... 334, 335		Control
	Distribution System..... 338		Secondary Circuit Application 262,		Light-Sensitive..... 516
	Transmission System..... 337		318 to 320		Manual..... 516
	Relaying..... 340		Economics..... 318, 319		Photoelectric..... 516
	Sub-Synchronous Resonance.. 340,		Fault Protection..... 319		Pilot Wire..... 517
	341, 358		Network..... 319		Time-Clock..... 517
	Voltage Improvement..... 262, 269		Standards..... 303, 304		Costs
	Service Reliability		Surge Protection..... 329		Cost Comparison..... 526 to 530
	Banked Secondaries..... 138		Substation Banks..... 262, 311		Fixed Charges..... 527, 528, 529
	Primary Feeders..... 109		Switched (See <i>Switched Capacitors</i>)		Initial Cost..... 527, 528, 529
	Primary Network..... 116		Switching Devices..... 322 to 324		Luminaire Cost, Net..... 526
	Service Requirements..... 32		System KVAR Supply..... 308		Operating Cost..... 527, 528, 529
	Services..... 134		Telephone Interference..... 334		Design Practice, U.G. Residential
	Cable, Self-Supporting..... 135, 136		Transient Voltage and Current.. 304		Distribution..... 553 to 555
	Conductor Capacity..... 134, 135		Voltage on Banks with Faulty		Filament Lamps (See <i>Incandescent</i>
	Faults..... 135		Capacitors..... 314, 315		<i>Lamp</i>)

PAGE		PAGE		PAGE
	Street Lighting (continued)		Street Lighting (continued)	
	Fluorescent Lamps (See <i>Fluorescent Lamps</i>)		Vehicular Traffic, Classification	496
	Fluorescent-Mercury Lamps	500, 501	Sub-Synchronous Resonance	358
	Foot Candle	495	Substation Voltage Regulation	271
	Footlambert	495	Bus	271
	History	495	Cost	273, 274, 275
	Incandescent Lamp (See <i>Incandescent Lamp</i>)		Dissimilar Feeders	273, 274, 275
	International Candle	495	Individual Feeder	273
	Lumen	495	Line Drop Compensator Sellings	293
	Luminaire	496	Regulation Range	276 to 278
	Maintenance	524 to 526	Schematic Diagram of	271, 272
	Secondary Current Check	525	Subtransmission Substations	88
	Voltage Check	525	Bus Arrangements	88 to 91
	Multiple System	512 to 515	Subtransmission System <i>Chapter 3</i>	
	Advantages	512	Area Coverage	98 to 103
	Ballast	514	Application to System	99 to 103
	Circuit-Arrangement	512, 513	General Principle	98, 99
	Circuit Switch	513	Physical Arrangement	102
	Characteristics	513, 514	Capability	91 to 95
	Interrupting Rating	513, 514	Cost, Estimating	
	RCC	513	Circuit Breakers, Outdoor Oil	106
	Conductors	515	Circuit, per Mile	106
	Limitations	512	Substation Structure	106
	MR Multiple Relay	513, 514	Cost, Factors Affecting	103
	Protection of	515	Cost Study	104
	Transformers	512, 513	Method, Calculating Cost	105
	Voltages	512	Results, Cost Analysis	106, 107
	Mercury Lamps (See <i>Incandescent Lamps</i>)		Circuit KVA Rating	91
	Pedestrian Traffic, Classification	496	Design, Basic Principles	92, 93
	Reflection Factor	496	Economics	103 to 107
	Replacement of Lamps		Function of	1
	Group	524	Line Losses	95 to 98
	Individual	524	Thermally-Loaded Lines	95, 96, 97
	Series Multiple System		Voltage Drop—	
	Application	515	Limited Lines	97, 98
	Circuit Arrangement	515, 516	Series Capacitor Applications	336, 337
	Corrective Measures of		Substation	88 to 91
	Troubles	525	(See <i>Subtransmission Substations</i>)	
	Limitations	516	Types, Basic	5, 6
	MR Multiple Relay	515, 516	Grid	88
	SR Series—		Loop	87, 88
	Multiple Relay	515, 516	Radial	87
	Series System	502 to 512	Ring	87, 88
	Application	503	Tapped-Tie	88
	Cables	510	Underground	66
	Cascading	507, 510	Voltage Drop	93, 94
	Circuit Arrangement	502, 503	Voltage Levels	86, 87
	Circuit Switch	507, 509	Supplementary Regulators	260, 261
	Control Circuit	507	Regulation Range	278
	RCC	507, 509	Surge Protection	
	Conductors	509, 510	Distribution Transformers	127, 201
	Corrective Measures of		Meters	431
	Trouble	525, 526	Secondary Circuits	130
	Current Ratings	503	Shunt Capacitors	329
	Film Cutout	509, 510	Street Lighting	511
	Grounding	511, 512	Underground Systems,	
	Lightning Protection	511, 512	Residential	145
	Limitations	503	Switched Capacitors	261, 268, 269, 276, 317
	Open-Circuit Protection	510, 511	Controls	286, 317, 324 to 327
	PC Protective Relay	510, 511	(See Also <i>Shunt Capacitors and Power Capacitors</i>)	
	Schematic Diagram	504	Current	325
	Transformers, Constant		Temperature	327
	Current	504 to 507	Time-Switch	286, 317, 324
	(See Also <i>Constant Current Transformers</i>)		Voltage	286, 287, 317, 325
	Voltage	503	Voltage—Current	326
	Sodium Lamps	501	Voltage—Time	325
	System Selection	517, 518	Coordination with Voltage	
	Transformers Capacity Calculation (See <i>Constant Current Transformers</i>)		Regulators	297, 298
			High Voltage Application	312, 313
			Network	320
			Switched Capacitors (continued)	
			Primary Feeder Application	261, 269, 276, 315 to 318
			Resistor Switching Device	323, 324
			Switching Devices	313, 322 to 324
			Reignition	322
			Resistor	323, 324
			Restrike	322, 323
			Transient Current,	
			High Frequency	323
			Substation Application	268, 269, 271, 312
			Switching Device, Capacitor	313, 322 to 324
			Synchronous Condensers,	
			Flicker Reduction	308, 354, 355
			Synchronous Motors	
			Service Interruption Momentary	363
			Sub-Synchronous Resonance	340, 341
			Voltage Effect	253
			Tap Changing Mechanism	
			URL	267
			URS	264
			Tap Changing Underload	264, 267
			Tap Selection, Transformer	218 to 221
			Tapped-Tie Subtransmission	7, 88
			Telemetry	466
			Telephone Interference	239, 241
			Shunt Capacitor	334
			Temperature Rise,	
			Distribution Transformers	205
			Terminal Arrangement,	
			Wathour Meters	454
			Testing, Meters	
			Demand Meter	464
			Methods	463
			Procedure	464
			Wathour Meter	464
			Thermal Ampere Demand Meters	460
			Thermal KW Demand Meters	460
			Third Harmonic Exciting Current	235
			Tie-Circuits, Primary System	109
			Time Delay Relay	283
			Characteristic Curve	283
			Time Delay Survey	283
			Time-Switch Control,	
			Shunt Capacitors	286, 324
			Torque, Wathour Meters	
			Driving	428
			Due to Alternating Fields	430
			Friction	431
			Retarding	428, 430, 431
			Totalizing Metering	466 to 468
			Trans-A-Sockets, Meter	447, 449, 454
			Transformer Breaker,	
			Primary Network Unit	113
			Transformer Capacity,	
			Ratio of Load to	173
			Transformer Connections	
			Delta-Delta	225, 226, 237
			Delta Secondary,	
			Mid-tap Grounded	232, 233
			Open-Delta	229, 237, 238
			Open-Wye	229, 239
			Phase Shift	233
			T-T	231, 233
			Wye-Delta	223, 238, 239
			Wye-Wye	226 to 228, 235 to 237
			Transformers	
			Aging of Insulation	242, 243
			Aging Time, Equivalent	243
			Air-Cooled	201
			Application Chart	218 to 222

	PAGE		PAGE		PAGE
Transformers (continued)		Transformers (continued)		Underground Residential (continued)	
ASA Guide for Loading.....	195, 241	Losses		Secondary Network.....	151
Basic Insulation Level.....	210	Load.....	214, 215, 216	Semi-buried Transformer	
Booster.....	223	No-Load (Core).....	216, 217	Housings.....	145
Bushing Arrangement.....	203, 204	Losses, Evaluation.....	245, 246	Service Connection...146, 553 to 555	
Bushing Insulation Level... 210, 211		Copper (Load).....	245, 246	Street Lighting.....	553 to 555
Coincidence Factor.....	246	Core (No-load).....	245	Telephone Cable.....	553 to 555
Completely-Self-Protecting (See		Exciting Current.....	245	Transformers...144, 145, 553 to 555	
CSP Distribution Transformer)		Network (See Network Transformers)		Trenching.....	145
(Also See CSP Power Transformer)		Neutral Inversion.....	235, 236	Underground Secondary Network (See	
Completely-Self-Protecting—Banking		Oil-filled.....	201	Secondary Network)	
(See CSPB Distribution Transformer)		Overload Characteristics.....	241	Unit Substation.....	48, 61, 62
Connections (See Transformer		Parallel Operation.....	224	Unlatching Time,	
Connections)		Phase-Shift,		Circuit Breakers.....	384, 386, 387
Constant Current,		Different Connections.....	233	Utilization Factor.....	24
Street Lighting.....	504 to 507	Phase Shifting (See Phase-Shifting		Utilization Voltage.....	248 to 253
Conventional.....	201	Transformers)		Design Voltage for Equipment...251	
Conversion of Ohms to		Polarity.....	207, 208, 209	Effect of Voltage Spread on	
Per Cent.....	175, 214, 548	Potential (See		Electronic Equipment.....	253
Cooling, Methods.....	201	Potential Transformers)		Fluorescent Lamps.....	252
Costs.....	221	Primary Network.....	113	Incandescent Lamps.....	251
Cost per Kva.....	221, 222	Ratings.....	125, 210, 212, 213, 214	Induction Motors.....	253, 254
Operating.....	128	Voltage.....	206, 207	Mercury Lamps.....	252
Current (See Current Transformers)		Regulation.....	218	Resistance Heating	
Current Protected.....	203 to 205	Formula.....	218	Devices.....	252, 253
Developments, CSP.....	244	With Single-Phase		Synchronous Motors.....	253
Dielectric Test.....	208, 210	Loads.....	235, 236	Extreme Zone.....	251
Distribution.....	1, 201	Semi-buried		Favorable Zone.....	249
Distribution Substation.....	47, 48	Application.....	144, 145, 204	Tolerable Zone.....	249
Duplex.....	230, 231	Semi-buried Type		Voltage Spread.....	247, 248
Efficiency.....	217, 218	Housings.....	144, 145, 204, 205		
Equivalent Circuit,		Short-Time Overload.....	241	Varhour Metering.....	449 to 458
Balanced Three-Phase		Standards		Average Power Factor.....	455
Negative Sequence...224, 225,		Short-Circuit.....	205	Single Phase System.....	455
549, 550		Temperature.....	205	Type K-1 Compensator.....	455
Positive Sequence...224, 225,		Street Lighting,		Three-Phase System.....	455
549, 550		Multiple System.....	512, 513	Phase Shifting Transformers 455, 456	
Zero Sequence.....224, 225,		Subway-Type.....	203	Internal Wiring.....	455, 457
549, 550		Surge Protection.....	127	Test.....	455, 456
Single-Phase.210, 211, 213, 214, 222		Tap Selection.....	218 to 221	Type K-5 Phase Shifting	
Schematic		Terminal Marking.206, 207, 208, 209		Transformer.....	455, 458
Representation.....	210, 211	Third Harmonic Exciting		Two-Phase System.....	455
Series—		Current.....	235	Connection Diagram.....	456
Multiple Secondary...222, 223		Unequal Size Banks,		Voltage	
Three-wire Secondary...222, 223		Three-Phase Connection.....	230	Balanced.....	29, 30, 31
Two-winding.....	222, 223	Voltage Drop.....	131	Base.....	248
Function of.....	1	Residential Area		Distribution Transformers...206, 207	
Furnace.....	353	Applications.....	255	Higher Primary.....	260
Fused Protection...393, 397 to 399,		Rural Area		Higher Secondary.....	125, 135
402, 403		Applications.....	255, 256	Maximum.....	247
Hot-Spot Temperature.....	241, 243	Voltage Rating.....	206, 207	Multiple Street Lighting.....	512
Impedance.....	206, 214, 215, 216	Zero Sequence Impedance,		Nominal.....	247
Impulse Strength.....	210	Three-phase Banks.....	226, 227	Potential Transformers.470, 473, 475	
Inerteen-Filled.....	201	Transockets, Meter.....	447, 449, 454	Primary Feeder.....	8, 117, 118
Instrument (See Instrument		Trench, Underground System...145, 146		Primary Networks.....	11, 113, 115
Transformers)		Trigonometric Functions.....	551, 552	Rated.....	247
Insulation Classes.....	208, 210, 211	Trip-Free Control, Circuit Breakers...383		Regulation, Definition.....	248
Neutral.....	210, 211	Tungsten Filament Lamp, Flicker 345, 346		Secondary Network Feeders...171	
Reduced Levels.....	210, 211			Secondary Networks	
Life.....	242	Underground, Residential.....	15, 16,	Overhead.....	186
Expectancy.....	243, 244	142 to 146		Underground.....	151
Functional Life Testing.....	244	Advantage.....	142	Secondary System.....	125, 126, 151
Load Factor.....	128	Cables.....	145, 553 to 555	Series Street Lighting.....	503
Load Growth.....	129	Cost.....	142, 143, 553 to 555	Service.....	247
Loading.....	127, 241	Design Practice,		Substation.....	250
ASA Guide.....	195, 241	28 Companies.....	553 to 555	Subtransmission.....	86, 87, 250
Changeout Chart.....	129	Fault Protection.....	144	Systems.....	14, 250
Changeout Value...128, 129, 130		Flexibility, Load Growth.....	143	Utilization.....	122, 248 to 253
CSP, Distribution.....	244	Loop Primary Sectionalizing...113,		Voltage Dip (See Also Utilization Voltage)	
Nomogram for Determining		144, 553 to 555		Due to Motor Starting.....	133
from KWHR.....	41	Primary Feeder Arrangement...144		Effect on Utilization	
Loss Factor.....	245	Primary Voltage.....	553 to 555	Equipment.....	361, 362
Loss Ratio.....	218	Secondary Circuits,		(See Also Flicker)	
		Design Practice.....	553 to 555	In Banked Secondaries.....	138, 141

PAGE		PAGE		PAGE
	Voltage Drop In		Voltage Regulators (continued)	
	Definition..... 247		Parallel Operation Methods (Cont'd)	
	Distribution Transformers . 131, 255		Out-of-Switch..... 300	
	Permissible Limit..... 247, 250, 251		Reversed Reactance Control. 300	
	Primary Feeders..... 255, 256		Step-by-Step Switch..... 300	
	Industrial..... 256, 257		Regulation Range of	
	Residential..... 254 to 256		Station Regulators... 276 to 278	
	Rural..... 255 to 257		Supplementary Regulators. 278	
	Secondary Circuit..... 132, 134, 255		Series Capacitors..... 269	
	Secondary Main, Networks..... 151		(See Also <i>Series Capacitors</i>)	
	Services..... 135, 255, 256		Step-Type Feeder..... 264 to 267	
	Subtransmission System..... 93, 94		(See Also <i>Step-Type Voltage</i>	
	Voltage Regulating Relay 281		<i>Regulators</i>)	
	Band Width Survey..... 283		Switched Capacitors..... 269, 286	
	Induction Disc..... 282		(See Also <i>Switched Capacitors</i>)	
	MAGAMP..... 282		Voltage Spread	
	Solenoid-Operated..... 282		At Transformer Terminal..... 122	
	Voltage Regulators		Definition..... 247	
	By Passing..... 269 to 271		Effect on	
	Control Accuracy..... 285, 286		Electronic Equipment..... 253	
	Controls..... 281 to 287		Fluorescent Lamps..... 252	
	Magamp..... 282		Incandescent Lamps..... 251	
	Time Delay Relay... 283 to 285		Induction Motors..... 253, 254	
	Voltage Regulating		Mercury Lamps..... 252	
	Relay..... 281 to 283		Resistance Heating	
	Comparison Chart,		Devices..... 252, 253	
	Parallel Operation..... 301		Synchronous Motors..... 253	
	Coordination..... 294 to 298		Wattour Meter	
	Step Regulators in Series... 295		Application	
	With Fixed Capacitors 295 to 297		Single-Phase,	
	With Switched		Three-Wire... 435, 438, 439	
	Capacitors..... 297, 298		Single-Phase, Two-Wire.... 438	
	Flicker Correction..... 356		Six-Phase, Six-Wire..... 446	
	Generator..... 263		Three-Phase, Four-Wire,	
	Induction-Type..... 267, 268		Delta..... 443 to 445	
	(See Also <i>Induction Regulators</i>)		Three-Phase, Four-Wire,	
	KVA Rating		Wye..... 441 to 443	
	Determination..... 278 to 280		Three-Phase, Three-Wire... 439	
	Line Drop Compensator... 281, 287		Totalizing Metering... 446, 448	
	(See Also <i>Line Drop</i>		Two-Phase, Five-Wire.... 446	
	<i>Compensation</i>)		Two-Phase, Four-Wire. 445, 446	
	Load Tap Changer (LTC) . 258, 263		Two-Phase,	
	(See Also <i>Load Tap Changer</i>)		Three-Wire Network. 440, 441	
	MAG-A-STAT..... 357		Blondel's Theorem..... 435	
	Parallel Operation		Characteristics..... 432, 433	
	Primary Networks..... 298		Circuit Connections	
	Secondary Networks..... 299		Self-Contained..... 448, 449	
	Parallel Operation Methods. 300 to 302		Transformer-Rated..... 450, 451	
	Comparison Chart..... 301		Constants..... 462	
	Cross-Current..... 300		Gear Ratio..... 462, 463	
	Current-Balance..... 300		Register..... 462	
	Difference Current..... 300		Register Ratio..... 462, 463	
	Mechanical Tie..... 300			
			Wattour Meter (continued)	
			Constants (continued)	
			Relationships..... 462, 463	
			Wattour..... 462	
			Wattsecond..... 462, 463	
			Construction..... 428, 429	
			Driving Mechanism..... 428	
			Driving Torque..... 428	
			Eddy Current..... 429	
			Electromagnet..... 428, 429, 430	
			Friction Torque..... 431	
			Internal Wiring Diagram... 452, 453	
			Isometric Wiring..... 428	
			Metering Varhours (See <i>Varhour</i>	
			<i>Metering</i>)	
			Performance Under Variation of	
			Frequency..... 432	
			Temperature..... 432	
			Voltage..... 432	
			Wave Form..... 432	
			Permanent Magnets..... 430	
			Rating	
			Current..... 434	
			Preferred..... 433, 434, 436, 437	
			Standard..... 434	
			Test Current..... 434	
			Voltage and Frequency. 434, 437	
			Register..... 428, 429, 431, 432	
			Registration	
			Effect of Power Factor.... 430	
			Voltage Characteristics... 432	
			Retarding Mechanism..... 428	
			Retarding Torque... 428, 430, 431	
			Scalar or Dot Product of	
			Phasors..... 434, 435	
			Schematic Diagram..... 428	
			Socket Selector Guide..... 447	
			Speed of Rotating Disk.... 427, 428	
			Surge Protection..... 431	
			Terminal Arrangement,	
			Sockets and Mounts..... 454	
			Testing..... 463, 464	
			Stroboscopic Method..... 464	
			Theory..... 429 to 432	
			Trans-A-Mounts..... 447, 449, 454	
			Transockets..... 447, 449, 454	
			Welders, Electric..... 355	
			Zero Sequence Circuit,	
			Transformer..... 224, 225	
			Zero Sequence Resistance, Line..... 546	
			Zero Sequence Shunt Capacitive	
			Reactance Factor..... 547	

The following terms, which appear in this book, are Trademarks of the Westinghouse Electric Corporation and its Subsidiaries:

Autotrol, CSP, CSPB, De-ion, Inerteen, Life-Guard, Mag-A-Stat, Main-streeter, Quicklag, Space-Miser, Sterilamp, Trans-A-Mount, Transocket, Tri-Pac

PRINTED BY R. R. DONNELLEY & SONS COMPANY, CHICAGO AND CRAWFORDSVILLE, INDIANA

Gridco, Inc. v. Varentec, Inc. IPR2017-01135
GRIDCO 1004 Part 5 of 5 - 576/576