



US008942107B2

(12) **United States Patent**
Austerman, III et al.

(10) **Patent No.:** **US 8,942,107 B2**
(45) **Date of Patent:** **Jan. 27, 2015**

- (54) **PIECE OF ETHERNET TERMINAL EQUIPMENT**
- (75) Inventors: **John F. Austerman, III**, Huntington Woods, MI (US); **Marshall B. Cummings**, Troy, MI (US)
- (73) Assignee: **ChriMar Systems, Inc.**, Farmington Hills, MI (US)
- (*) Notice: Subject to any disclaimer, the term of this patent is extended or adjusted under 35 U.S.C. 154(b) by 0 days.
- (21) Appl. No.: **13/370,918**
- (22) Filed: **Feb. 10, 2012**

(65) **Prior Publication Data**
US 2012/0250784 A1 Oct. 4, 2012

- (63) **Related U.S. Application Data**
Continuation of application No. 12/239,001, filed on Sep. 26, 2008, now Pat. No. 8,155,012, which is a continuation of application No. 10/668,708, filed on Sep. 23, 2003, now Pat. No. 7,457,250, which is a continuation of application No. 09/370,430, filed on Aug. 9, 1999, now Pat. No. 6,650,622, which is a continuation-in-part of application No. PCT/US99/07846, filed on Apr. 8, 1999.
- (60) Provisional application No. 60/081,279, filed on Apr. 10, 1998.

- (51) **Int. Cl.**
H04L 12/12 (2006.01)
G08B 13/14 (2006.01)
H04L 1/24 (2006.01)
H04B 3/54 (2006.01)
- (52) **U.S. Cl.**
CPC .. **H04L 1/24** (2013.01); **H04B 3/54** (2013.01); **H04B 2203/5445** (2013.01); **H04B 2203/5458** (2013.01); **H04B 2203/5466** (2013.01); **H04B 2203/547** (2013.01); **H04B 2203/5491** (2013.01); **H04B 2203/5495** (2013.01)

USPC **370/241**; 370/463; 340/568.1
(58) **Field of Classification Search**
None
See application file for complete search history.

(56) **References Cited**
U.S. PATENT DOCUMENTS
202,495 A 4/1878 Watson
244,426 A 7/1881 Bell
(Continued)

FOREIGN PATENT DOCUMENTS
CA 2183106 A1 2/1998
CN 2050662 U 1/1990
(Continued)

OTHER PUBLICATIONS
"10BaseT Takes Off" (LAN Magazine, May 1991).
(Continued)

Primary Examiner — Chi H Pham
Assistant Examiner — Soon-Dong D Hyun
(74) *Attorney, Agent, or Firm* — Harness, Dickey & Pierce, P.L.C.

(57) **ABSTRACT**
A piece of Ethernet terminal equipment having an Ethernet connector including first and second pairs of contacts used to carry Ethernet communication signals. At least one path for the purpose of drawing DC current. The at least one path coupled across at least one of the contacts of the first pair of contacts and at least one of the contacts of the second pair of contacts. The piece of Ethernet terminal equipment to draw different magnitudes of DC current flow via the at least one path. The different magnitudes of DC current flow to result from at least one condition applied to at least one of the contacts of the first and second pairs of contacts, wherein at least one of the magnitudes of the DC current flow to convey information about the piece of Ethernet terminal equipment.

125 Claims, 13 Drawing Sheets

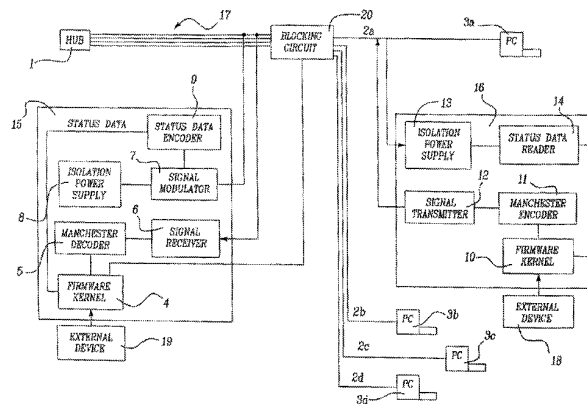

(56)

References Cited

U.S. PATENT DOCUMENTS

| | | | | | | | |
|-----------|---|---------|-------------------|-----------|---|---------|-----------------------|
| 406,567 | A | 7/1889 | Edison | 4,397,020 | A | 8/1983 | Howson |
| 2,846,509 | A | 8/1958 | Dubuar | 4,398,066 | A | 8/1983 | Sinberg |
| 3,359,379 | A | 12/1967 | Pullum et al. | 4,410,982 | A | 10/1983 | Fleischfresser et al. |
| 3,407,400 | A | 10/1968 | Lurie | 4,413,250 | A | 11/1983 | Porter et al. |
| 3,408,643 | A | 10/1968 | Sliman | 4,438,298 | A | 3/1984 | Rubin |
| 3,423,521 | A | 1/1969 | Friesen et al. | 4,446,341 | A | 5/1984 | Rubin |
| 3,425,050 | A | 1/1969 | Tellerman et al. | 4,454,477 | A | 6/1984 | Joffe |
| 3,500,132 | A | 3/1970 | Garrett | 4,463,352 | A | 7/1984 | Forbes et al. |
| 3,535,472 | A | 10/1970 | Babbitt, III | 4,464,658 | A | 8/1984 | Thelen |
| 3,537,095 | A | 10/1970 | Cones | 4,467,147 | A | 8/1984 | Rubin |
| 3,593,274 | A | 7/1971 | Krugler, Jr. | 4,467,314 | A | 8/1984 | Weikel et al. |
| 3,597,549 | A | 8/1971 | Farmer et al. | 4,475,079 | A | 10/1984 | Gale |
| 3,618,065 | A | 11/1971 | Trip et al. | 4,479,228 | A | 10/1984 | Crane |
| 3,634,845 | A | 1/1972 | Colman | 4,482,999 | A | 11/1984 | Janson et al. |
| 3,659,277 | A | 4/1972 | Brown | 4,484,028 | A | 11/1984 | Kelley et al. |
| 3,696,378 | A | 10/1972 | Daniel | 4,487,836 | A | 12/1984 | Takayanagi et al. |
| 3,697,984 | A | 10/1972 | Atkinson et al. | 4,494,541 | A | 1/1985 | Archibald |
| 3,731,012 | A | 5/1973 | Shaffer | 4,495,494 | A | 1/1985 | McCune |
| 3,758,728 | A | 9/1973 | Le Roch et al. | 4,507,568 | A | 3/1985 | Ziegler et al. |
| 3,768,084 | A | 10/1973 | Haynes | 4,524,349 | A | 6/1985 | Hyatt |
| 3,781,481 | A | 12/1973 | Shaffer et al. | 4,525,636 | A | 6/1985 | Kominami et al. |
| 3,794,989 | A | 2/1974 | Manley et al. | 4,527,216 | A | 7/1985 | Stammely |
| 3,818,179 | A | 6/1974 | Mase | 4,528,667 | A | 7/1985 | Fruhauf |
| 3,828,139 | A | 8/1974 | Chambers, Jr. | 4,532,626 | A | 7/1985 | Flores et al. |
| 3,832,521 | A | 8/1974 | Niendorf | 4,535,401 | A | 8/1985 | Penn |
| 3,832,678 | A | 8/1974 | Gysell et al. | 4,551,671 | A | 11/1985 | Annunziata et al. |
| 3,836,901 | A | 9/1974 | Matto et al. | 4,564,726 | A | 1/1986 | Ibata |
| 3,842,218 | A | 10/1974 | DeLuca et al. | 4,571,656 | A | 2/1986 | Ruckman |
| 3,848,179 | A | 11/1974 | Kayama | 4,575,714 | A | 3/1986 | Rummel |
| 3,863,036 | A | 1/1975 | McCrudden | 4,578,539 | A | 3/1986 | Townsing |
| 3,868,484 | A | 2/1975 | Bolton et al. | 4,586,104 | A | 4/1986 | Standler |
| 3,886,419 | A | 5/1975 | Omura et al. | 4,593,389 | A | 6/1986 | Wurzburg et al. |
| RE28,692 | E | 1/1976 | Highstone et al. | 4,602,364 | A | 7/1986 | Herman et al. |
| 3,932,857 | A | 1/1976 | Way et al. | 4,611,101 | A | 9/1986 | Walter et al. |
| 3,969,594 | A | 7/1976 | DeLuca et al. | 4,617,656 | A | 10/1986 | Kobayashi et al. |
| 3,983,338 | A | 9/1976 | Mathauser | 4,622,541 | A | 11/1986 | Stockdale |
| 4,024,359 | A | 5/1977 | De Marco et al. | 4,629,836 | A | 12/1986 | Walsworth |
| 4,024,360 | A | 5/1977 | Biraghi et al. | 4,631,367 | A | 12/1986 | Coviello et al. |
| 4,054,760 | A | 10/1977 | Morgen | 4,633,217 | A | 12/1986 | Akano |
| 4,063,220 | A | 12/1977 | Metcalfe et al. | 4,636,771 | A | 1/1987 | Ochs |
| 4,064,431 | A | 12/1977 | Cote | 4,639,714 | A | 1/1987 | Crowe |
| 4,101,878 | A | 7/1978 | Shimizu et al. | 4,647,721 | A | 3/1987 | Busam et al. |
| 4,121,201 | A | 10/1978 | Weathers | 4,647,912 | A | 3/1987 | Bates et al. |
| 4,128,804 | A | 12/1978 | Russell | 4,649,548 | A | 3/1987 | Crane |
| 4,131,767 | A | 12/1978 | Weinstein | 4,654,638 | A | 3/1987 | Clift |
| 4,156,799 | A | 5/1979 | Cave | 4,654,640 | A | 3/1987 | Carll et al. |
| 4,160,884 | A | 7/1979 | Bishop | 4,656,318 | A | 4/1987 | Noyes |
| 4,161,719 | A | 7/1979 | Parikh et al. | 4,658,099 | A | 4/1987 | Frazer |
| 4,162,489 | A | 7/1979 | Thilo et al. | 4,658,242 | A | 4/1987 | Zeder |
| 4,173,714 | A | 11/1979 | Bloch et al. | 4,661,797 | A | 4/1987 | Schmall |
| 4,179,688 | A | 12/1979 | Romney | 4,661,979 | A | 4/1987 | Jakab |
| 4,186,339 | A | 1/1980 | Finger | 4,670,902 | A | 6/1987 | Naiwirt |
| 4,191,971 | A | 3/1980 | Dischert et al. | 4,674,084 | A | 6/1987 | Suzuki et al. |
| 4,230,912 | A | 10/1980 | Lee et al. | 4,685,129 | A | 8/1987 | Gavrilovich |
| 4,232,199 | A | 11/1980 | Boatwright et al. | 4,686,514 | A | 8/1987 | Liptak, Jr. et al. |
| 4,254,305 | A | 3/1981 | Treiber | 4,691,344 | A | 9/1987 | Brown et al. |
| 4,260,882 | A | 4/1981 | Barnes | 4,692,761 | A | 9/1987 | Robinton |
| 4,268,723 | A | 5/1981 | Taylor | 4,701,630 | A | 10/1987 | Annunziata et al. |
| 4,273,955 | A | 6/1981 | Armstrong | 4,701,946 | A | 10/1987 | Oliva et al. |
| 4,277,740 | A | 7/1981 | Parks | 4,712,233 | A | 12/1987 | Kuo |
| 4,282,407 | A | 8/1981 | Stiefel | 4,717,896 | A | 1/1988 | Graham |
| 4,290,056 | A | 9/1981 | Chow | 4,719,616 | A | 1/1988 | Akano |
| 4,292,480 | A | 9/1981 | Sweatt | 4,723,267 | A | 2/1988 | Jones et al. |
| 4,293,948 | A | 10/1981 | Soderblom | 4,728,948 | A | 3/1988 | Fields |
| 4,303,073 | A | 12/1981 | Archibald | 4,729,125 | A | 3/1988 | Sterling, Jr. et al. |
| 4,313,081 | A | 1/1982 | Smith | 4,731,810 | A | 3/1988 | Watkins |
| 4,315,107 | A | 2/1982 | Ciesielka et al. | 4,731,829 | A | 3/1988 | Bonnet et al. |
| 4,322,677 | A | 3/1982 | Wright | 4,733,223 | A | 3/1988 | Gilbert |
| 4,340,788 | A | 7/1982 | Sbuelz | 4,733,389 | A | 3/1988 | Puvogel |
| 4,348,661 | A | 9/1982 | Lucchesi | 4,736,195 | A | 4/1988 | McMurtry et al. |
| 4,349,703 | A | 9/1982 | Chea, Jr. | 4,737,787 | A | 4/1988 | Ito et al. |
| 4,350,849 | A | 9/1982 | Ahuja | 4,742,334 | A | 5/1988 | Teich et al. |
| 4,367,455 | A | 1/1983 | Fried | 4,751,498 | A | 6/1988 | Shalvi et al. |
| 4,383,315 | A | 5/1983 | Torng | 4,755,792 | A | 7/1988 | Pezzolo et al. |
| 4,388,667 | A | 6/1983 | Saurenman | 4,755,922 | A | 7/1988 | Puvogel |
| | | | | 4,758,823 | A | 7/1988 | Berruyer et al. |
| | | | | 4,760,382 | A | 7/1988 | Faulkner |
| | | | | 4,766,386 | A | 8/1988 | Oliver et al. |
| | | | | 4,771,229 | A | 9/1988 | Ziegler |

| (56) | References Cited | | | | |
|-------------|-----------------------|-------------------|---------------|---------|--------------------------------|
| | U.S. PATENT DOCUMENTS | | | | |
| 4,779,153 A | 10/1988 | Tsubota | 5,093,828 A | 3/1992 | Braun et al. |
| 4,782,322 A | 11/1988 | Lechner et al. | RE33,900 E | 4/1992 | Howson |
| 4,782,355 A | 11/1988 | Sakai et al. | 5,119,398 A | 6/1992 | Webber, Jr. |
| 4,782,482 A | 11/1988 | Kiatipov et al. | 5,119,402 A | 6/1992 | Ginzburg et al. |
| 4,785,812 A | 11/1988 | Pihl et al. | 5,121,482 A | 6/1992 | Patton |
| 4,799,211 A | 1/1989 | Felker et al. | 5,121,500 A | 6/1992 | Arlington et al. |
| 4,813,066 A | 3/1989 | Holtz et al. | 5,124,982 A | 6/1992 | Kaku |
| 4,815,106 A | 3/1989 | Propp et al. | 5,131,033 A | 7/1992 | Reum |
| 4,817,106 A | 3/1989 | Thompson | 5,133,005 A | 7/1992 | Kelley et al. |
| 4,821,319 A | 4/1989 | Middleton et al. | 5,136,580 A | 8/1992 | Videlock et al. |
| 4,823,600 A | 4/1989 | Biegel et al. | 5,142,269 A | 8/1992 | Mueller |
| 4,825,349 A | 4/1989 | Marcel | 5,144,544 A | 9/1992 | Jenneve et al. |
| 4,839,886 A | 6/1989 | Wu et al. | 5,148,144 A | 9/1992 | Sutterlin et al. |
| 4,862,158 A | 8/1989 | Keller et al. | 5,164,960 A | 11/1992 | Wincon et al. |
| 4,864,598 A | 9/1989 | Lynch et al. | 5,168,170 A | 12/1992 | Hartig |
| 4,866,768 A | 9/1989 | Sinberg | 5,179,291 A | 1/1993 | Nishikawa et al. |
| 4,875,223 A | 10/1989 | Curtis | 5,179,710 A | 1/1993 | Coschieri |
| 4,882,728 A | 11/1989 | Herman | 5,181,240 A | 1/1993 | Sakuragi et al. |
| 4,884,263 A | 11/1989 | Suzuki | 5,189,409 A | 2/1993 | Okuno |
| 4,884,287 A | 11/1989 | Jones et al. | 5,192,231 A | 3/1993 | Dolin, Jr. |
| 4,885,563 A | 12/1989 | Johnson et al. | 5,195,183 A | 3/1993 | Miller et al. |
| 4,896,315 A | 1/1990 | Felker et al. | 5,199,049 A | 3/1993 | Wilson |
| 4,901,003 A | 2/1990 | Clegg | 5,200,743 A | 4/1993 | St. Martin et al. |
| 4,901,217 A | 2/1990 | Wilson | 5,200,877 A | 4/1993 | Betton et al. |
| 4,903,006 A | 2/1990 | Boomgaard | 5,216,704 A | 6/1993 | Williams et al. |
| 4,907,261 A | 3/1990 | Chapman | 5,222,164 A | 6/1993 | Bass, Sr. et al. |
| 4,916,621 A | 4/1990 | Bean et al. | 5,223,806 A | 6/1993 | Curtis et al. |
| 4,918,688 A | 4/1990 | Krause et al. | 5,226,120 A | 7/1993 | Brown et al. |
| 4,922,503 A | 5/1990 | Leone | 5,231,375 A | 7/1993 | Sanders et al. |
| 4,926,158 A | 5/1990 | Zeigler | 5,235,599 A | 8/1993 | Nishimura et al. |
| 4,935,926 A | 6/1990 | Herman | 5,237,606 A | 8/1993 | Ziermann |
| 4,935,959 A | 6/1990 | Markovic et al. | 5,241,160 A | 8/1993 | Bashan et al. |
| 4,937,811 A | 6/1990 | Harris | 5,243,328 A | 9/1993 | Lee et al. |
| 4,937,851 A | 6/1990 | Lynch et al. | 5,249,183 A | 9/1993 | Wong et al. |
| 4,942,604 A | 7/1990 | Smith et al. | 5,255,962 A | 10/1993 | Neuhaus et al. |
| 4,951,309 A | 8/1990 | Gross et al. | 5,257,287 A | 10/1993 | Blumenthal et al. |
| 4,953,055 A | 8/1990 | Douhet et al. | 5,260,664 A | 11/1993 | Graham |
| 4,958,371 A | 9/1990 | Damoci et al. | 5,264,777 A | 11/1993 | Smead |
| 4,961,222 A | 10/1990 | Johansson et al. | 5,267,238 A | 11/1993 | Yano et al. |
| 4,969,179 A | 11/1990 | Kanare et al. | 5,270,896 A | 12/1993 | McDonald |
| 4,973,954 A | 11/1990 | Schwarz | 5,275,172 A | 1/1994 | Ives |
| 4,980,913 A | 12/1990 | Skret | 5,278,888 A | 1/1994 | Myllymaki |
| 4,991,123 A | 2/1991 | Casamassima | 5,280,251 A | 1/1994 | Strangio |
| 4,992,774 A | 2/1991 | McCullough | 5,285,477 A | 2/1994 | Leonowich |
| 4,998,275 A | 3/1991 | Braunstein et al. | 5,289,359 A | 2/1994 | Ziermann |
| 4,998,850 A | 3/1991 | Crowell | 5,289,458 A | 2/1994 | Taha |
| 5,003,457 A | 3/1991 | Ikei et al. | 5,289,461 A | 2/1994 | de Nijs |
| 5,003,579 A | 3/1991 | Jones | 5,297,141 A | 3/1994 | Marum |
| 5,007,858 A | 4/1991 | Daly et al. | 5,301,246 A | 4/1994 | Archibald et al. |
| 5,020,100 A | 5/1991 | Gardiner | 5,302,889 A | 4/1994 | Marsh |
| 5,020,773 A | 6/1991 | Tuft et al. | 5,306,956 A | 4/1994 | Ikeda et al. |
| 5,021,779 A | 6/1991 | Bisak | 5,311,114 A | 5/1994 | Sambamurthy et al. |
| 5,029,201 A | 7/1991 | Bindels | 5,311,518 A | 5/1994 | Takato et al. |
| 5,032,819 A | 7/1991 | Sakuragi et al. | 5,313,642 A | 5/1994 | Seigel |
| 5,032,833 A | 7/1991 | Laporte | 5,315,237 A | 5/1994 | Iwakura et al. |
| 5,033,112 A | 7/1991 | Bowling et al. | 5,319,363 A | 6/1994 | Welch et al. |
| 5,034,723 A | 7/1991 | Maman | 5,321,372 A | 6/1994 | Smith |
| 5,034,738 A | 7/1991 | Ishihara et al. | 5,323,461 A | 6/1994 | Rosenbaum et al. |
| 5,034,948 A | 7/1991 | Mizutani et al. | 5,333,177 A | 7/1994 | Braitberg et al. |
| 5,034,978 A | 7/1991 | Nguyen et al. | 5,333,192 A | 7/1994 | McGinn |
| 5,038,782 A | 8/1991 | Gevins et al. | 5,336,946 A | 8/1994 | Segaram et al. |
| 5,051,723 A | 9/1991 | Long et al. | 5,345,422 A | 9/1994 | Redwine |
| 5,055,827 A | 10/1991 | Philipp | 5,345,592 A | 9/1994 | Woodmas |
| 5,056,131 A | 10/1991 | Kanare et al. | 5,347,225 A | 9/1994 | Graham |
| 5,059,782 A | 10/1991 | Fukuyama | 5,351,272 A | 9/1994 | Abraham |
| 5,059,948 A | 10/1991 | Desmeules | 5,353,009 A | 10/1994 | Marsh et al. |
| 5,063,563 A | 11/1991 | Ikeda et al. | 5,357,145 A | 10/1994 | Segaram |
| 5,063,585 A | 11/1991 | Shapiro | 5,365,515 A | 11/1994 | Graham |
| 5,066,939 A | 11/1991 | Mansfield, Jr. | 5,368,041 A | 11/1994 | Shambroom |
| 5,066,942 A | 11/1991 | Matsuo | 5,379,441 A | 1/1995 | Watanabe et al. |
| 5,073,919 A | 12/1991 | Hagensick | 5,381,804 A | 1/1995 | Shambroom |
| 5,076,763 A | 12/1991 | Anastos et al. | 5,384,429 A | 1/1995 | Bulson et al. |
| 5,077,526 A | 12/1991 | Vokey et al. | 5,389,882 A | 2/1995 | I'Anson et al. |
| RE33,807 E | 1/1992 | Abel et al. | 5,391,932 A | 2/1995 | Small et al. |
| 5,089,974 A | 2/1992 | Demeyer et al. | 5,396,555 A | 3/1995 | Shibata et al. |
| | | | 5,406,260 A * | 4/1995 | Cummings et al. 340/568.2 |
| | | | 5,408,669 A | 4/1995 | Stewart et al. |
| | | | 5,414,708 A | 5/1995 | Webber et al. |
| | | | 5,414,709 A | 5/1995 | Baze |

(56)

References Cited

U.S. PATENT DOCUMENTS

| | | | | | |
|-------------|---------|-----------------------|-------------|---------|------------------|
| 5,420,572 A | 5/1995 | Dolin, Jr. et al. | 5,652,479 A | 7/1997 | LoCascio et al. |
| 5,422,519 A | 6/1995 | Russell | 5,652,575 A | 7/1997 | Pryor et al. |
| 5,424,710 A | 6/1995 | Baumann | 5,652,893 A | 7/1997 | Ben-Meir et al. |
| 5,432,505 A | 7/1995 | Wise | 5,652,895 A | 7/1997 | Poisner |
| 5,438,606 A | 8/1995 | Cerulli | 5,655,077 A | 8/1997 | Jones et al. |
| 5,440,335 A | 8/1995 | Beveridge | 5,659,542 A | 8/1997 | Bell et al. |
| 5,441,520 A | 8/1995 | Olsen et al. | 5,664,002 A | 9/1997 | Skinner, Sr. |
| 5,444,184 A | 8/1995 | Hassel | 5,670,937 A | 9/1997 | Right et al. |
| 5,444,856 A | 8/1995 | Bowers et al. | 5,671,354 A | 9/1997 | Ito et al. |
| 5,446,914 A | 8/1995 | Paul et al. | 5,675,321 A | 10/1997 | McBride |
| 5,448,565 A | 9/1995 | Chang et al. | 5,675,371 A | 10/1997 | Barringer |
| 5,450,486 A | 9/1995 | Maas et al. | 5,675,811 A | 10/1997 | Broedner et al. |
| 5,451,923 A | 9/1995 | Seberger et al. | 5,675,813 A | 10/1997 | Holmdahl |
| 5,452,344 A | 9/1995 | Larson | 5,678,547 A | 10/1997 | Faupel et al. |
| 5,455,467 A | 10/1995 | Young et al. | 5,678,559 A | 10/1997 | Drakulic |
| 5,457,629 A | 10/1995 | Miller et al. | 5,679,987 A | 10/1997 | Ogawa |
| 5,459,283 A | 10/1995 | Birdwell, Jr. | 5,684,826 A | 11/1997 | Ratner |
| 5,461,671 A | 10/1995 | Sakuragi et al. | 5,684,950 A | 11/1997 | Dare et al. |
| 5,467,061 A | 11/1995 | Aden et al. | 5,686,826 A | 11/1997 | Kurtz et al. |
| 5,467,384 A | 11/1995 | Skinner, Sr. | 5,687,174 A | 11/1997 | Edem et al. |
| 5,469,437 A | 11/1995 | Runaldue | 5,689,230 A | 11/1997 | Merwin et al. |
| 5,477,091 A | 12/1995 | Fiorina et al. | 5,692,917 A | 12/1997 | Rieb et al. |
| 5,483,574 A | 1/1996 | Yuyama | 5,696,660 A | 12/1997 | Price |
| 5,483,656 A | 1/1996 | Oprescu et al. | 5,706,287 A | 1/1998 | Leimkoetter |
| 5,485,488 A | 1/1996 | Van Brunt et al. | 5,715,174 A | 2/1998 | Cotichini et al. |
| 5,488,306 A | 1/1996 | Bonaccio | 5,715,287 A | 2/1998 | Wadhawan et al. |
| 5,491,463 A | 2/1996 | Sargeant et al. | 5,729,154 A | 3/1998 | Taguchi et al. |
| 5,493,684 A | 2/1996 | Gephardt et al. | 5,729,204 A | 3/1998 | Fackler et al. |
| 5,497,460 A | 3/1996 | Bailey et al. | 5,742,216 A | 4/1998 | Iwasaki et al. |
| 5,498,911 A | 3/1996 | Bossler et al. | 5,742,514 A | 4/1998 | Bonola |
| 5,513,370 A | 4/1996 | Paul | 5,742,833 A | 4/1998 | Dea et al. |
| 5,514,859 A | 5/1996 | Seigel | 5,756,280 A | 5/1998 | Soora et al. |
| 5,515,303 A | 5/1996 | Cargin, Jr. et al. | 5,758,101 A | 5/1998 | Pemberton |
| 5,517,172 A | 5/1996 | Chiu | 5,761,084 A | 6/1998 | Edwards |
| 5,519,882 A | 5/1996 | Asano et al. | 5,764,647 A | 6/1998 | Riley |
| 5,523,747 A | 6/1996 | Wise | 5,766,133 A | 6/1998 | Faisandier |
| 5,526,349 A | 6/1996 | Diaz et al. | 5,768,301 A | 6/1998 | Dreyer et al. |
| 5,528,248 A | 6/1996 | Steiner et al. | 5,779,196 A | 7/1998 | Timar |
| 5,528,507 A | 6/1996 | McNamara et al. | 5,781,015 A | 7/1998 | Duffin et al. |
| 5,528,661 A | 6/1996 | Siu et al. | 5,783,999 A | 7/1998 | Price et al. |
| 5,531,611 A | 7/1996 | Reed et al. | 5,784,441 A | 7/1998 | Davis et al. |
| 5,532,898 A | 7/1996 | Price | 5,790,363 A | 8/1998 | Chaudhry |
| 5,535,336 A | 7/1996 | Smith et al. | 5,793,764 A | 8/1998 | Bartoldus et al. |
| 5,537,468 A | 7/1996 | Hartmann | 5,796,185 A | 8/1998 | Takata et al. |
| 5,540,235 A | 7/1996 | Wilson | 5,796,965 A | 8/1998 | Choi et al. |
| 5,541,957 A | 7/1996 | Lau | 5,799,040 A | 8/1998 | Lau |
| 5,548,466 A | 8/1996 | Smith | 5,799,194 A | 8/1998 | Allen et al. |
| 5,560,022 A | 9/1996 | Dunstan et al. | 5,799,196 A | 8/1998 | Flannery |
| 5,560,357 A | 10/1996 | Faupel et al. | 5,802,042 A | 9/1998 | Natarajan et al. |
| 5,563,489 A | 10/1996 | Murry | 5,802,305 A | 9/1998 | McKaughan et al. |
| 5,568,525 A | 10/1996 | de Nijs et al. | 5,805,597 A | 9/1998 | Edem |
| 5,570,002 A | 10/1996 | Castleman | 5,805,904 A | 9/1998 | Jung |
| 5,572,182 A | 11/1996 | De Pinho Filho et al. | 5,808,846 A | 9/1998 | Holce et al. |
| 5,574,748 A | 11/1996 | Vander Mey et al. | 5,810,606 A | 9/1998 | Ballast et al. |
| 5,577,023 A | 11/1996 | Marum et al. | 5,812,531 A | 9/1998 | Cheung et al. |
| 5,577,026 A | 11/1996 | Gordon et al. | 5,814,900 A | 9/1998 | Esser et al. |
| 5,578,991 A | 11/1996 | Scholder | 5,815,665 A | 9/1998 | Teper et al. |
| 5,581,772 A | 12/1996 | Nanno et al. | 5,821,868 A | 10/1998 | Kuhling |
| 5,586,054 A | 12/1996 | Jensen et al. | 5,828,293 A | 10/1998 | Rickard |
| 5,594,332 A | 1/1997 | Harman et al. | 5,834,942 A | 11/1998 | De Angelis |
| 5,594,732 A | 1/1997 | Bell et al. | 5,835,005 A | 11/1998 | Furukawa et al. |
| 5,596,473 A | 1/1997 | Johnson et al. | 5,836,785 A | 11/1998 | Lee |
| 5,596,637 A | 1/1997 | Pasetti et al. | 5,838,683 A | 11/1998 | Corley et al. |
| 5,608,545 A | 3/1997 | Kagawa | 5,841,203 A | 11/1998 | Chambers et al. |
| 5,608,792 A | 3/1997 | Laidler | 5,841,360 A | 11/1998 | Binder |
| 5,610,593 A | 3/1997 | Seto | 5,842,955 A | 12/1998 | Wilkinson |
| 5,617,418 A | 4/1997 | Shirani et al. | 5,845,150 A | 12/1998 | Henion |
| 5,623,184 A | 4/1997 | Rector | 5,845,190 A | 12/1998 | Bushue et al. |
| 5,630,058 A | 5/1997 | Mosley et al. | 5,848,149 A | 12/1998 | Chen et al. |
| 5,631,570 A | 5/1997 | King | 5,854,824 A | 12/1998 | Bengal et al. |
| 5,631,846 A | 5/1997 | Szurkowski | 5,854,839 A | 12/1998 | Chen et al. |
| 5,635,896 A | 6/1997 | Tinsley et al. | 5,859,584 A | 1/1999 | Counsell et al. |
| 5,642,248 A | 6/1997 | Campolo et al. | 5,859,596 A | 1/1999 | McRae |
| 5,645,434 A | 7/1997 | Leung | 5,884,086 A | 3/1999 | Amoni et al. |
| 5,649,001 A | 7/1997 | Thomas et al. | 5,896,415 A | 4/1999 | Owens et al. |
| | | | 5,896,509 A | 4/1999 | Sugimoto |
| | | | 5,909,445 A | 6/1999 | Schneider |
| | | | 5,915,002 A | 6/1999 | Shimosako |
| | | | 5,918,016 A | 6/1999 | Brewer et al. |

(56)

References Cited

U.S. PATENT DOCUMENTS

| | | | | | | | |
|-----------|-----|---------|------------------------------|-----------|----|---------|----------------------|
| 5,920,253 | A | 7/1999 | Laine | 6,172,606 | B1 | 1/2001 | Lockyer |
| 5,920,266 | A | 7/1999 | Allgood et al. | 6,175,556 | B1 | 1/2001 | Allen, Jr. et al. |
| 5,923,363 | A | 7/1999 | Elberbaum | 6,178,176 | B1 | 1/2001 | Voloshin et al. |
| 5,923,663 | A * | 7/1999 | Bontemps et al. 370/445 | 6,178,455 | B1 | 1/2001 | Schutte et al. |
| 5,929,624 | A | 7/1999 | Ricq et al. | 6,178,458 | B1 | 1/2001 | Wang |
| 5,929,626 | A | 7/1999 | Iwasaki et al. | 6,178,514 | B1 | 1/2001 | Wood |
| 5,929,778 | A | 7/1999 | Asama et al. | 6,181,140 | B1 | 1/2001 | Vokey et al. |
| 5,933,073 | A | 8/1999 | Shuey | 6,186,803 | B1 | 2/2001 | Garside |
| 5,933,590 | A | 8/1999 | Allen | 6,205,137 | B1 | 3/2001 | Ariga |
| 5,937,033 | A | 8/1999 | Bellows | 6,215,789 | B1 | 4/2001 | Keenan et al. |
| 5,939,801 | A | 8/1999 | Bouffard et al. | 6,218,930 | B1 | 4/2001 | Katzenberg et al. |
| 5,944,659 | A | 8/1999 | Flach et al. | 6,219,216 | B1 | 4/2001 | Holce et al. |
| 5,944,824 | A | 8/1999 | He | 6,222,852 | B1 | 4/2001 | Gandy |
| 5,944,831 | A | 8/1999 | Pate et al. | 6,233,613 | B1 | 5/2001 | Walker et al. |
| 5,946,180 | A | 8/1999 | Simpson | 6,233,689 | B1 | 5/2001 | Allen et al. |
| 5,948,077 | A | 9/1999 | Choi et al. | 6,236,625 | B1 | 5/2001 | Schell et al. |
| 5,949,806 | A | 9/1999 | Ness et al. | 6,236,653 | B1 | 5/2001 | Dalton et al. |
| 5,949,974 | A | 9/1999 | Ewing et al. | 6,243,394 | B1 | 6/2001 | Deng |
| 5,953,314 | A | 9/1999 | Ganmukhi et al. | 6,243,818 | B1 | 6/2001 | Schwan et al. |
| 5,960,208 | A | 9/1999 | Obata et al. | 6,246,748 | B1 | 6/2001 | Yano |
| 5,963,557 | A | 10/1999 | Eng | 6,252,878 | B1 | 6/2001 | Locklear, Jr. et al. |
| 5,971,804 | A | 10/1999 | Gallagher et al. | 6,253,121 | B1 | 6/2001 | Cline et al. |
| 5,991,311 | A | 11/1999 | Long et al. | 6,259,745 | B1 | 7/2001 | Chan |
| 5,991,885 | A | 11/1999 | Chang et al. | 6,272,219 | B1 | 8/2001 | De Bruycker et al. |
| 5,994,998 | A | 11/1999 | Fisher et al. | 6,272,552 | B1 | 8/2001 | Melvin et al. |
| 5,995,348 | A | 11/1999 | McCartan et al. | 6,275,498 | B1 | 8/2001 | Bisceglia et al. |
| 5,995,353 | A | 11/1999 | Cunningham et al. | 6,278,357 | B1 | 8/2001 | Croushore et al. |
| 6,000,003 | A | 12/1999 | Allen et al. | 6,278,665 | B1 | 8/2001 | Schell et al. |
| 6,005,760 | A | 12/1999 | Holce et al. | 6,279,060 | B1 | 8/2001 | Luke et al. |
| 6,009,479 | A | 12/1999 | Jeffries | 6,292,901 | B1 | 9/2001 | Lys et al. |
| 6,011,680 | A | 1/2000 | Solleder et al. | 6,295,356 | B1 | 9/2001 | De Nicolo |
| 6,011,794 | A | 1/2000 | Mordowitz et al. | 6,295,569 | B1 | 9/2001 | Shimura et al. |
| 6,011,910 | A | 1/2000 | Chau et al. | 6,300,847 | B1 | 10/2001 | Gallagher et al. |
| 6,016,519 | A | 1/2000 | Chida et al. | 6,301,527 | B1 | 10/2001 | Butland et al. |
| 6,018,452 | A | 1/2000 | Meyerhoefer et al. | 6,311,173 | B1 | 10/2001 | Levin et al. |
| 6,021,493 | A | 2/2000 | Cromer et al. | 6,314,102 | B1 | 11/2001 | Czerwiec et al. |
| 6,021,496 | A | 2/2000 | Dutcher et al. | 6,317,675 | B1 | 11/2001 | Stolz et al. |
| 6,031,368 | A | 2/2000 | Klippel et al. | 6,324,268 | B1 | 11/2001 | Balachandran et al. |
| 6,033,101 | A | 3/2000 | Reddick et al. | 6,329,810 | B1 | 12/2001 | Reid |
| 6,038,457 | A | 3/2000 | Barkat | 6,332,166 | B1 | 12/2001 | Cranford, Jr. et al. |
| 6,042,390 | A | 3/2000 | Leung | 6,344,794 | B1 | 2/2002 | Ulrich et al. |
| 6,044,081 | A | 3/2000 | Bell et al. | 6,348,874 | B1 | 2/2002 | Cole et al. |
| 6,047,376 | A | 4/2000 | Hosoe | 6,349,353 | B1 | 2/2002 | Lewis et al. |
| 6,049,139 | A | 4/2000 | Nagaura et al. | 6,351,648 | B1 | 2/2002 | Karapetkov et al. |
| 6,049,881 | A | 4/2000 | Massman et al. | 6,359,906 | B1 | 3/2002 | Dyke et al. |
| 6,057,670 | A | 5/2000 | Sink et al. | 6,362,909 | B1 | 3/2002 | Bedrosian |
| 6,064,305 | A | 5/2000 | Lockyer | 6,366,143 | B1 | 4/2002 | Liu et al. |
| 6,069,899 | A | 5/2000 | Foley | 6,366,208 | B1 | 4/2002 | Hopkins et al. |
| 6,091,722 | A | 7/2000 | Russell et al. | 6,366,618 | B1 | 4/2002 | Miller |
| 6,092,131 | A | 7/2000 | Caldwell et al. | 6,373,851 | B1 | 4/2002 | Dadario |
| 6,092,196 | A | 7/2000 | Reiche | 6,377,874 | B1 | 4/2002 | Ykema |
| 6,095,867 | A | 8/2000 | Brandt et al. | 6,383,076 | B1 | 5/2002 | Tiedeken |
| 6,097,761 | A | 8/2000 | Buhring et al. | 6,384,755 | B1 | 5/2002 | Hayden |
| 6,100,471 | A | 8/2000 | Fouache | 6,385,030 | B1 | 5/2002 | Beene |
| 6,101,459 | A | 8/2000 | Tavallaei et al. | 6,393,050 | B1 | 5/2002 | Liu |
| 6,108,330 | A | 8/2000 | Bhatia et al. | 6,393,474 | B1 | 5/2002 | Eichert et al. |
| 6,111,936 | A | 8/2000 | Bremer | 6,393,607 | B1 | 5/2002 | Hughes et al. |
| 6,115,468 | A | 9/2000 | De Nicolo | 6,396,391 | B1 | 5/2002 | Binder |
| 6,121,778 | A | 9/2000 | Moore | 6,398,779 | B1 | 6/2002 | Buyse et al. |
| 6,125,448 | A | 9/2000 | Schwan et al. | 6,415,244 | B1 | 7/2002 | Dickens et al. |
| 6,130,894 | A | 10/2000 | Ojard et al. | 6,418,332 | B1 | 7/2002 | Mastrototaro et al. |
| 6,130,896 | A | 10/2000 | Lueker et al. | 6,420,976 | B1 | 7/2002 | Baggs et al. |
| 6,134,666 | A | 10/2000 | De Nicolo | 6,449,348 | B1 | 9/2002 | Lamb et al. |
| 6,137,839 | A | 10/2000 | Mannering et al. | 6,456,625 | B1 | 9/2002 | Itoi |
| 6,140,911 | A | 10/2000 | Fisher et al. | 6,459,175 | B1 | 10/2002 | Potega |
| 6,141,763 | A | 10/2000 | Smith et al. | 6,473,608 | B1 | 10/2002 | Lehr et al. |
| 6,144,722 | A | 11/2000 | Anderson et al. | 6,480,510 | B1 | 11/2002 | Binder |
| 6,147,601 | A | 11/2000 | Sandelman et al. | 6,483,903 | B1 | 11/2002 | Itay et al. |
| 6,147,603 | A | 11/2000 | Rand | 6,496,103 | B1 | 12/2002 | Weiss et al. |
| 6,147,963 | A | 11/2000 | Walker et al. | 6,504,825 | B1 | 1/2003 | Atkins et al. |
| 6,154,488 | A | 11/2000 | Hunt | 6,522,151 | B2 | 2/2003 | Armistead et al. |
| 6,157,534 | A | 12/2000 | Gallagher et al. | 6,526,516 | B1 | 2/2003 | Ishikawa et al. |
| 6,169,475 | B1 | 1/2001 | Browning | 6,529,127 | B2 | 3/2003 | Townsend et al. |
| 6,169,883 | B1 | 1/2001 | Vimpari et al. | 6,535,983 | B1 | 3/2003 | McCormack et al. |
| 6,171,152 | B1 | 1/2001 | Kunz | 6,546,494 | B1 | 4/2003 | Jackson et al. |
| | | | | 6,571,181 | B1 | 5/2003 | Rakshani et al. |
| | | | | 6,587,454 | B1 | 7/2003 | Lamb |
| | | | | 6,640,308 | B1 | 10/2003 | Keyghobad et al. |
| | | | | 6,643,566 | B1 | 11/2003 | Lehr et al. |

(56)

References Cited

U.S. PATENT DOCUMENTS

| | | | |
|-----------|----|---------|--------------------|
| 6,658,108 | B1 | 12/2003 | Bissell et al. |
| 6,665,306 | B1 | 12/2003 | Thakur et al. |
| 6,681,013 | B1 | 1/2004 | Miyamoto |
| 6,701,443 | B1 | 3/2004 | Bell |
| 6,744,831 | B2 | 6/2004 | Chan |
| 6,744,888 | B1 | 6/2004 | El-Kik et al. |
| 6,753,671 | B1 | 6/2004 | Harvey |
| 6,762,675 | B1 | 7/2004 | Cafiero et al. |
| 6,795,493 | B1 | 9/2004 | Huang |
| 6,889,095 | B1 | 5/2005 | Eidson et al. |
| 7,116,779 | B1 | 10/2006 | Meyerhoefer et al. |
| 7,158,483 | B1 | 1/2007 | Takabatake et al. |
| 7,275,255 | B2 | 9/2007 | Suda et al. |

FOREIGN PATENT DOCUMENTS

| | | | |
|----|------------|----|---------|
| CN | 1117614 | A | 2/1996 |
| CN | 1150359 | A | 5/1997 |
| DE | 3907652 | A1 | 9/1990 |
| DE | 4203304 | A1 | 8/1992 |
| DE | 4138065 | A1 | 5/1993 |
| EP | 0093095 | A3 | 12/1986 |
| EP | 0357482 | A2 | 3/1990 |
| EP | 0386659 | A2 | 9/1990 |
| EP | 0415312 | A1 | 3/1991 |
| EP | 0639916 | A2 | 2/1995 |
| EP | 0584447 | B1 | 6/1997 |
| EP | 0852018 | B1 | 5/2003 |
| FR | 2682843 | A1 | 4/1993 |
| GB | 2249919 | A | 5/1992 |
| JP | 60164289 | A | 8/1985 |
| JP | 63018741 | A | 1/1988 |
| JP | 63059144 | A | 3/1988 |
| JP | 1016053 | A | 1/1989 |
| JP | 1160198 | A | 6/1989 |
| JP | 2087762 | A | 3/1990 |
| JP | 02226836 | A | 9/1990 |
| JP | 3143130 | A | 6/1991 |
| JP | 4020192 | A | 1/1992 |
| JP | 4180430 | A | 6/1992 |
| JP | 04358493 | A | 12/1992 |
| JP | 05012576 | A | 1/1993 |
| JP | 5150854 | A | 6/1993 |
| JP | 06012579 | A | 1/1994 |
| JP | 06075652 | A | 3/1994 |
| JP | 06216913 | A | 8/1994 |
| JP | 06261041 | A | 9/1994 |
| JP | H6244893 | | 9/1994 |
| JP | 07007517 | A | 1/1995 |
| JP | 08008903 | A | 1/1996 |
| JP | 08096900 | A | 4/1996 |
| JP | H8204782 | | 8/1996 |
| JP | 08265727 | A | 10/1996 |
| JP | H8307476 | | 11/1996 |
| JP | 08322164 | A | 12/1996 |
| JP | 09153905 | A | 6/1997 |
| JP | 09275387 | A | 10/1997 |
| JP | 9305508 | A | 11/1997 |
| JP | 09325927 | A | 12/1997 |
| JP | 10013576 | A | 1/1998 |
| JP | 1998013576 | A | 1/1998 |
| JP | 10041964 | A | 2/1998 |
| JP | 10066110 | A | 3/1998 |
| KR | 900007034 | B1 | 9/1990 |
| WO | WO-9217968 | A1 | 10/1992 |
| WO | WO-9302510 | A1 | 2/1993 |
| WO | WO-9623377 | A1 | 8/1996 |
| WO | WO-9627967 | A1 | 9/1996 |
| WO | WO-9629638 | A1 | 9/1996 |
| WO | WO-9628940 | A3 | 11/1996 |
| WO | WO-9628920 | A3 | 12/1996 |
| WO | WO-9709667 | A1 | 3/1997 |
| WO | WO-9857248 | A2 | 12/1998 |
| WO | WO-9934591 | A1 | 7/1999 |

OTHER PUBLICATIONS

"100 Mb/s data Transmission on UTP and STP Cabling for Demand Priority Networks" (By Hewlett Packard, HP Laboratories Bristol, HPL-94-88, Oct. 1994).

"100 Years of Bell Telephones" {Book} (Author: Richard Mountjoy, A Schiffer Book, 1995).

"\$500 Per Seat ATM?" (Business Communications Review, Jan. 1995).

AccessHub Line Unit—Model MMH-220 by PairGain Technologies, Inc.—Rev. 01, (Jul. 30, 1997), 20 pages.

Adtran—Model Adtran D448 U-BR1TE II ISDN 2B1Q Interface for Alcatel D448 Channel Banks Installation/Maintenance—Section 61430020L2-5—Issue 1, (Jul. 1997), 7 pages.

Advanced Micro Devices, Inc., Chipcom Corporation, Digital Equipment Corporation, Motorola Inc., and SynOptics Communications, Inc., "Shielded Twisted Pair Proposal for the TP-PMD Working Group" (Jun. 1991).

Advanced Micro Devices, "Implementing FDDI Over Copper—The ANSI X3T9.5 Standard—Application Note", Pub. #18258, Rev. A (Nov. 1993).

Advertisement for Watchdog Network Monitor, LAN Magazine, vol. 5, No. 6, (Jun. 1990), 5 pages.

"Alternate Copper Media for FDDI" by Chipcom Corporation, [33 pages] (Jun. 1990).

AMD, Chipcom, DEC, IBM, Motorola, SynOptics, "STP Proposal—Introduction", (Oct. 15, 1991).

AMD, Chipcom, DEC, IBM, Motorola and SynOptics, "Wire Fault Detect Function", ANSI X3T9.2 FDDI TP-PMD Working Group, (Oct. 15, 1991).

AMD, Chipcom, Digital, IBM, Motorola and SynOptics, "Report on Action Item to Merge STP-PMD Proposals", (Aug. 20, 1991).

An Interoperable Solution for FDDI Signaling Over Shielded Twisted Pair, Advanced Micro Devices, Inc., (May 21, 1990), 9 pages.

An Interoperable Solution for FDDI Signaling Over Shielded Twisted Pair, Advanced Micro Devices, (May 21, 1991), 25 pages.

Anonymous, "Theft Detection Means for Use with Coaxial Cables," (Undated), 1 page.

"ANSI/IEEE 802.4-1990"—"Information processing systems—Local area networks—Part 4: Token-passing bus access method and physical layer specifications" (1990).

"ANSI/IEEE Std 802.2"—"IEEE Standard for Information technology—Telecommunications and information exchange between systems—Local and metropolitan area networks—Specific requirements—Part 2: Logical Link Control" (1998 Edition).

"ANSI/IEEE Std 802.5-1985—ISO/DP 8802/5—Local area Networks—ANSI/IEEE Standard ISO Draft Proposal—Token Ring Access Method" (1985).

"ANSI/IEEE Std 802.5-1998E—Information technology—Telecommunications and information exchange between systems—Local and metropolitan area networks—Specific requirements—Part 5: Token ring access method and Physical Layer specifications" (1998).

"ANSI INCITS 229-1994 (R1999)"—"For Information Systems—Fibre Distributed Data Interface (FDDI)—Station Management (SMT)" (1994).

"ANSI X3.166-1990"—"For Information Systems"—"Fibre Distributed Data Interface (FDDI)—Token Ring Physical Layer Medium Dependent (PMD)" (1990).

"ANSI X3.166-1990"—"For Information Technology"—"Fibre Distributed Data Interface (FDDI)—Token Ring Twisted Pair Physical Layer Medium Dependent (TP-PMD)" (1990).

"ANSI X3.263-1995"—"For Information Technology"—"Fibre Distributed Data Interface (FDDI)—Token Ring Twisted Pair Physical Layer Medium Dependent (TP-PMD)" (1995).

"A proposal for a Low-Cost FDDI UTP/STP PMD Standard" by Mario Mazzola, Crescendo Communications [31 pages] (Oct. 15, 1991).

"ATM: Ready for Lift-Off" (Information Week, Feb. 6, 1995).

"ATM takes to twisted-pair" (Electronic Engineering Times, Dec. 19, 1994).

(56)

References Cited

OTHER PUBLICATIONS

- "ATM to run over copper wire" (Computer World, Jan. 23, 1995).
- "Attachment Module Guide for the IBM Token-Ring Network," IBM, Apr. 1992.
- Avaya, "MERLIN MAGIC Integrated System—Installation Release 3.0 and Earlier," 555-730-140, Issue 1, May 2003, 329 pages.
- "AT&T Merlin Phones," (Web Document), 3 pages.
- AT&T, "MERLIN Plus Communications System—Training Manual," Dec. 1986, 999-505-144, Issue 1, 80 pages.
- AT&T, "MERLIN Plus Communications System—System Planner," Sep. 1988, 999-501-141, Issue 1, 18 pages.
- AT&T, "MERLIN Plus Communications System—Release 1—Customization Chart," Nov. 1988, 999-503-146, Issue 1, 6 pages.
- "AT&T Merlin" (Wikipedia—Web Document), 3 pages.
- AT&T Technologies, "Telecommunications Transmission Engineering", vol. 1, Principles (1975).
- Avaya Communication, "Intuity Messaging Solutions Release 5 Integration with MERLIN LEGEND and MERLIN MAGIX Communications Systems," Jan. 2001, 585-310-748, Issue 2, Chapter 4, pp. 4-1-4-29.
- Bay Networks Public Information, "LattisNet (Pre-10BaseT Versus 10BaseT)", Technical Response Center, Technical Tip (Date Unknown).
- "Bear Sterns New Age Media II" (By Cliff Friedman) {Date Unknown}.
- Bradley, et al., "Track Devices on a Mac Network," The Local Area Network Magazine 7.n9, p. 162(1), (Sep. 1992).
- Bradley, et al., "Unix-based Tracking Software," The Local Area Network Magazine 7.n9, p. 162(2), (Sep. 1992).
- "Broadband to Homes" (Interactive Age, Dec. 12, 1994).
- "Cards to Handle Fast ATM on Standard Wire" (Communications Week, Nov. 14, 1994).
- Chapter I LattisNet Operation, Ethernet Connectivity Guide, 145 pages.
- "Cheap transceivers vault Tut into ATM, rural I-way markets" (MacWeek, Dec. 12, 1994).
- Chipcom Corporation, "FDDI—An Introduction to Fiber Distributed Data Interface" (Date Unknown).
- Chipcom, "Jan. 1992—FDDI Product Direction—FDDI Connectivity" (Jan. 1992).
- Chipcom Corporation, "Online FDDI Media Modules Release Notes" (Apr. 14, 1994).
- Cisco for All—"What is DSL and its Different Flavors?" (Date Unknown), 3 pages.
- "Cisco System backs proposed specification for FDDI over shielded twisted-pair" by Business Wire (May 22, 1991) and "News & Analysis FDDI Over STP? Sounds Great, But Where Is It?" by Laura Didio from LAN Times (Jun. 3, 1991) [1 page].
- Closeup Article—The LAN Inner Circle [15 pages] (Mar. 25, 1985).
- Coilcraft, "10 BASE T Transformers—Dual Transformer Package" (Jun. 1989).
- Colin, et al., "Testing the LAN Testers," Network World, (Sep. 10, 1990), pp. 39-40, 44-45, 48, 74.
- Communications Week, "Crescendo Preps PC CDDI Card" (Oct. 26, 1992).
- Communication Week Article: "FDDI Spec Consortium" [2 pages] (May 27, 1991).
- "ComNet focuses on routing, ATM" (PC Week, Jan. 23, 1995).
- "Companies Cooperate to Publish Open Specification for FDDI on Shielded Twisted Pair Cable"—"Five Industry Leaders Demonstrate Interoperability of Products" (Author Unknown) [2 pages] (May 21, 1991).
- Computerworld, "Network Peripherals Cuts FDDI Prices" (Dec. 7, 1992).
- Computerworld, "Vendors Back Next-Generation FDDI; Unshielded Twisted-Pair Products for High-Speed Nets Leapfrog Draft Standard" (May 3, 1993).
- Cook, John, "Line Codes for FDDI Over Copper" BT Laboratories, Copper Access Systems Section (Date Unknown).
- "Copper Cable with HDSL"—A Technology Brief from PairGain Technologies, Inc., (Date Unknown), 5 pages.
- Crescendo Communications, Mazzola, Mario; "A Proposal for a Low-Cost FDDI UTP/STP PMD Standard" (Oct. 15, 1991).
- CSN, "Hub Makers Seek FDDI Link" (Oct. 14, 1991).
- "Daisy-Chain Ethernet" (BYTE, Jan. 1995).
- Darrow, Barbara, "Chipcom LAN Concentrator Spans Multiple Protocols, Cabling Schemes", Info World, (Jan. 29, 1990).
- "Data Cabling—Still in the Melting Pot?" (by the Cabling Partnership) (Jul. 21, 1998).
- Data Communications—McGraw-Hill's Technology Magazine for Network Managers: "Multivendor token ring networks coming of age" [5 pages] (Nov. 21, 1989).
- "Data Net" (Electronic News, Jan. 23, 1993).
- DEC Concentrator 500 (Technical Description), Jul. 1992.
- Design of a Twisted Pair Cable for a Token Passing Local Area Network (Intl. Wire & Cable Symposium Proceedings) by Paul Abramson—IBM Corporation [3 pages] (1983).
- Digital Equipment Corporation, Intel Corporation and Xerox Corporation, "The Ethernet, A Local Area Network, Data Link Layer and Physical Layer Specifications" (Version 1.0, pp. 53-57, Sep. 30, 1980).
- "Digital Subscriber Line," (Jun. 1999), Cisco—Internet Technology Overview, Chapter 15, pp. 15-1-15-12.
- "Digital Subscriber Line Access Multiplexer (DSLAM)," by Freescale Semiconductor, (Dec. 2004), 4 pages.
- "Digital Subscriber Line Access Multiplexer (DSLAM)," (Date Unknown), The International Engineering Consortium, 20 pages.
- Dixon, Roy C., "Lore of the Token Ring", IEEE Network Magazine, (Jan. 1987, vol. 1, No. 1, pp. 11-38).
- Dixon, R.C.; Strole, N.C.; Markov, J.D., "A Token-Ring Network for Local Data Communications", IBM Systems Journal, vol. 22, Nos. 1/2, (1983).
- "DSLAM: Digital Subscriber Line Access Multiplexer," (Date Unknown), NetworkDictionary, 1 page.
- "EIA Interim Standard Omnibus Specification—Local Area Network Twisted Pair Data Communications Cable—NQ-EIA/IS-43" (EIA, Sep. 1987).
- EIA/TIA 568 Standard, "Commercial Building Telecommunications Wiring Standard," Jul. 1991.
- EIA/TIA Bulletin, TSB-36, "Technical Systems Bulletin Additional Cable Specifications for Unshielded Twisted Pair Cables," Nov. 1991.
- EIA/TIA Bulletin, TSB40, "Additional Transmission Specifications for Unshielded Twisted Pair Connecting Hardware," Aug. 1992.
- Electronic Design, "FDDI Rides Twisted Pair to the Desktop" (Sep. 16, 1993).
- Electronic Engineering Times, "Startups Launch Twisted-Pair Networks" (May 4, 1992).
- Electronic Industries Association, "Interface Between Data Terminal Equipment and Data Communication Equipment Employing Serial Binary Data Interchange" EIA Standard, EIA-232-C (Aug. 1969).
- Electronic Industries Association, "Electrical Characteristics of Balanced Voltage Digital Interface Circuits" EIA Standard, RS-422 (Apr. 1975).
- Electronic Industries Association, "Standard for Electrical Characteristics of Generators and Receivers for Use in Balanced Digital Multipoint Systems" EIA Standard, EIA-485 (Apr. 1983).
- Electronic News, "Firms Agree on Twisted Pair Fast Data" (May 18, 1992).
- Entertainment Services and Technology Association (ESTA)—Recommended Practice for Ethernet Cabling Systems in Entertainment Lighting Applications [44 pages] (1996).
- "E/O Networks aims to bring 'fiber to the farm'" (Electronic Engineering Times, Mar. 6, 1995).
- EtherPhone 220 Line Unit—Model EPH-220—PairGain—Revision History of This Practice—Rev. 1, (Nov. 1, 1997), 80 pages.
- EtherPhone RT Network Interface Device—Model EtherPhone RT by PairGain Technologies, Inc.—Revision History of This Practice—Rev. 1, (Nov. 7, 1997), 24 pages.
- EtherPhone RT Network Interface Device—Model EPH-RT by PairGain Technologies, Inc.—Revision History of This Practice—Rev. 1 (Feb. 7, 1997), 26 pages.

(56)

References Cited

OTHER PUBLICATIONS

- Evans, G., "The EIA Consumer Electronic Bus Twisted Pair Network," (May 1991), IEEE Transactions on Consumer Electronics, vol. 37, No. 2, pp. 101-107.
- "Fast ATM Comes to Copper" (Communications Week, Jan. 23, 1995).
- FDDI Metallic Media—Shielded Twisted Pair Physical Layer Medium Dependent, British Telecom, Oct. 15, 1991.
- FDDI Metallic Media—Unshielded Twisted Pair Physical Layer Medium Dependent (UTP-PMD), Draft Proposed American National Standard, X3T9.5 / 88-155 [34 pages] (Jun. 17, 1991).
- FDDI on Copper with AMD PHY, Advanced Micro Devices, 1991, 8 pages.
- "FDDI on STP" by Hank Foglia, IBM Communication Systems [19 pages] (Feb. 19, 1991).
- "FDDI—Shielded Twisted Pair and Data Grade Unshielded Twisted Pair Physical Layer Medium Dependent (STP/DTP-PMD)" by Cabletron Systems, FWS Engineering, and National Semiconductor [36 pages] (Dec. 6, 1991).
- "FDDI STP-PMD Proposal" (Author Unknown) [35 pages] (Date: Unknown).
- "FDDI—UTP—Investigation" by Synoptics [6 pages] (Date: Unknown).
- Fer, "FFOL—The FDDI Follow-On LAN" (Jul. 1991).
- Fiber Optics News, "Digital Equipment Corp. and Network Peripherals Make FDDI News . . . Working on FDDI Over Copper Specification, Leonard Says" (Jun. 24, 1991).
- Foglia, Hank, "FDDI on STP", IBM Communication Systems (Feb. 19, 1991).
- Gaston, "Intruder Detection," IBM Technical Disclosure Bulletin, vol. 11, No. 12, (May 1969), pp. 1723-1724.
- Glossary—FDDI Fiber Module, Version b1.0a (Author & Reference Unknown) [7 pages] (May 1992).
- H4000 Ethernet Transceiver Technical Manual [67 pages] (1982).
- Haight, Timothy, "A Twisted Future", Communications Week (Jun. 18, 1990).
- Haskin, Denis W., "Twisted-Pair Ethernet for Everyone", Digital Review, (Jul. 25, 1988).
- "HDSL Basics," (Oct. 1997), by TTC, 10 pages.
- "HDSL"—Introduction, (Date Unknown), Cisco, 1 page.
- Herivel, et al., "Security Alarm System," IBM Corporation, vol. 20, No. 8, (Jan. 1978), pp. 3237-3238.
- HiGain—HDSL2 Modules by ADC—Feb. 2003, 2 pages.
- HiGain—HLU-231, List 8E Line Unit—Quick Installation Guide by PairGain, 8 pages.
- HiGain HMU-319-L81 Quick Installation Guide by ADC, (Sep. 29, 2006), 12 pages.
- HiGain—Technical Practice—HXU-358 V1.04 Multiplexer Unit by ADC, (Apr. 6, 2001), 76 pages.
- HiGain—User Manual—"H2TU-C-319 List 2E Line Unit," (Apr. 21, 2000), 152-319-125-02, Issue 2, 74 pages.
- HiGain Doubler Unit—Model HDU-451 by PairGain Technologies, Inc. (1998), 46 pages.
- HiGain Line Unit—Model HLU-231 by PairGain Technologies, Inc., (1999), 78 pages.
- HiGain Line Unit—Model HLU-319 by PairGain Technologies, Inc.—Rev. 1, (Dec. 22, 1997), 56 pages.
- HiGain Line Unit—Quick Installation Guide—Model HLU-231 by PairGain Technologies, Inc.—350-231-165-01—Rev. 1, (Sep. 15, 1998), 28 pages.
- HiGain Line Unit—Quick Installation Guide—Model HLU-319 by PairGain Technologies, Inc.—350-319-153-01—Rev. 1, (Apr. 30, 1999), 20 pages.
- HiGain Line Unit—Quick Installation Guide—Model HLU-819 by PairGain Technologies, Inc.—350-819-200-01—Rev. 1, (Nov. 12, 1999), 42 pages.
- HiGain Remote Unit—Model HRU-412 by PairGain Technologies, Inc.—150-412-107-03, (Nov. 19, 1999), 38 pages.
- HiGain Remote Unit—Model HRU-412 by PairGain Technologies, Inc.—150-412-181-01, (Mar. 31, 1998), 42 pages.
- HiGain Wideband 3190 Integrated SONET/DS3 Multiplexer for HDSL/HDSL2/HDSL4—Spec Sheet—by ADC—Jun. 2007, 8 pages.
- Hill, et al., "16Mb/s Token Ring on Unshielded Twisted Pair Cabling," IEEE, (1991), pp. 67-72.
- Howard W. Sams & Co., Inc., "Reference Data for Engineers: Radio, Electronics, Computer, and Communications" Seventh Edition, Fifth Printing (1989).
- Hutchison, Jerry, "Update on ASC X3T9.5 FDDI", Digital Equipment, Tutorial, (Jul. 11, 1988).
- IBM—"8209 LAN Bridge—Attachment Module Guide for the IBM Token-Ring Network," #GA27-3915-01, (Apr. 1992), 187 pages.
- "IBM and SynOptics Develop New Technology to Support 16/4 Mbs Token Ring Over Unshielded Twisted Pair Wiring" by SynOptics Communications, Inc. [5 pages] (Feb. 24, 1992).
- IBM Cabling System Planning and Installation Guide, # GA27-3361-07 [344 pages] (Oct. 1987).
- IBM Cabling System, Technical Interface Specification, GA27-3773-1 (2nd Edition, Oct. 1987).
- IBM—"International Technical Support Organization High-Speed Networking Technology: An Introductory Survey", # GG24-3816-02 [480 pages] (Jun. 1995).
- IBM—"Local Area Network Concepts and Products: Adapters, Hubs and ATM", # SG24-4754-00 [326 pages.] (May 1996).
- IBM—"Local Area Network Concepts and Products: LAN Architecture", # SG24-4753-00 [262 pages] (May 1996).
- IBM Technical Disclosure Bulletin, "Remote Powering," No. 01-78, Published Jan. 1978, pp. 3164-3165.
- IBM—Technical Reference—Personal Computer Hardware Reference Library, # 69X7862 [476 pages] (Jun. 1986).
- IBM Token-Ring Network—Introduction and Planning Guide, # GA27-3677-03 [241 pages] (Sep. 1990).
- IBM Token-Ring Network Operates on Telephone Twisted-Pair Media (Marketing Announcement) by IBM [4 pages] (Oct. 15, 1985).
- IBM Token-Ring Network Technology, # GA27-3832-0 [146 pages] (1986).
- IEEE, "Media Access Control (MAC) Parameters Physical Layer, Medium Attachment Units, and Repeater for 100 Mb/s Operation, Type 100BASE-T (Clauses 21-30)," IEEE Std. 802.3u-1995.
- IEEE Network Magazine, vol. 1, No. 1, Jan. 1987, 30 pages.
- IEEE—P802.9f, D7, 1997, DS5554—"P802.9f Draft Standard Local and Metropolitan Area Networks—Supplement to Integrated Services (IS) LAN Interface at the Medium Access Control (MAC) and Physical (PHY) Layers," (1997), 36 pages.
- IEEE, "Physical Coding Sublayer (PCS), Physical Medium Attachment (PMA) Sublayer and Baseband Medium, Type 100BASE-T," IEEE Std. 802.3ab-1999.
- IEEE-SA Standards Board Bylaws, 3 pages.
- "IEEE Std 802-1990"—"IEEE Standards for Local and Metropolitan Area Networks: Overview and Architecture" (Nov. 20, 1990).
- "IEEE Std. 802.5c-1991"—"Supplement to Token Ring for Dual Access Method and Physical Layer Specifications"—"Recommended Practice for Dual Ring Operation with Wrapback Reconfiguration" (Mar. 21, 1991).
- IEEE Std 802.9-1994—"IEEE Standards for Local and Metropolitan Area Networks: Integrated Services (IS) LAN Interface at the Medium Access Control (MAC) and Physical (PHY) Layers," 436 pages.
- "IEEE Std 1802.3-1991"—"Carrier Sense Multiple Access with Collision Detection (CSMA/CD) Access Method and Physical Layer Specifications"—"Currently Contains Attachment Unit Interface (AUI) Cable (Section 4)" (Aug. 9, 1991).
- IEEE, "Twisted-Pair Medium Attachment Unit (MAU) and Baseband Medium, Type 10BASE-T," IEEE Std. 802.3i-1990 (Section 14) (1990).
- "Implementation and Applications of DSL Technology," {Book} (Authors: Golden, Dedieu & Jacobsen, Auerbach Publications, 2008).
- Information Processing Systems—Fibre Distributed Data Interface (FDDI) Part 3: Physical Layer Medium Dependent, Global Engineering Documents, 1989, 55 pages.

(56)

References Cited

OTHER PUBLICATIONS

- Information Processing Systems—Fibre Distributed Data Interface (FDDI) Part 2: Token Ring Media Access Control (MAC), Global Engineering Documents, 1989, 75 pages.
- Information Processing Systems—Fibre Distributed Data Interface (FDDI) Part 1: Token Ring Physical Layer Protocol (PHY), Global Engineering Documents, 1989, 38 pages.
- Info World Article: "100-MBPS FDDI Will Run in Twisted-Pair Wiring" by Margie Wylie and Barbara Darrow [1 page] (Jun. 18, 1990).
- "Integrated Services Digital Network (ISDN)," International Telecommunication Union, vol. III, Fascicle III.8, (Nov. 14-25, 1988), pp. 175-176 and 204-209.
- "Introduction to Telephones and Telephone Systems" {Book} (Author: A. Michael Noll, Second Edition, 1991).
- "ISO/IEC 8877"—"Information technology—Telecommunications and information exchange between systems—Interface connector and contact assignments for ISDN Basic Access Interface located at reference points S and T" (Second edition Nov. 15, 1992).
- "ISO/IEC 9314-4"—"Information technology—Fibre distributed data interface (FDDI)—Part 4: Single-mode fibre physical layer medium dependent (SMF/PMD)" (First edition Oct. 1999).
- "ISO/IEC 14709-2"—"Information technology—Configuration of Customer Premises Cabling (CPC) for Applications—Part 2: Integrated Services Digital Network (ISDN) primary rate" (First edition May 1998).
- "ITU-T 1.430"—"Integrated Services Digital Network (ISDN)—ISDN User-Network Interfaces"—"Basic User-Network Interface—Layer 1 Specification" (Nov. 1995).
- Keller, R., et al., "Performance Bottlenecks in Digital Movie Systems," Proceedings of the 4th International Workshop on Network and Operating System Support for Digital Audio and Video, Lancaster, U.K., Nov. 1983, 13 pages.
- King, "A Survey of Commercially Available Secure LAN Products," IEEE, (1990), pp. 239-247.
- Kummerie, K.; Reiser, M., "Local-Area Communication Networks—An Overview", Journal of Telecommunications Networks, Winter 1982, vol. 1, No. 4 (1982).
- LAN Computing, "Network Adapters" (Nov. 1991).
- LAN Technology, "Tut Cuts Thinnest" (Jun. 1992).
- LAN Times, "3Com Is Betting on FDDI for LANs; Ships FDDI Link NICs" (Jan. 25, 1993).
- LAN Times, "FDDI Over STP? Sounds Great, But Where Is It?" (Jun. 3, 1991).
- LAN Times, "Network Peripherals Cuts FDDI Prices by 50 Percent" (Dec. 21, 1992).
- LAN Times, "Tutankhamon Raises Level-2 UTP From the Tomb" (Mar. 22, 1993).
- "Lattisboot Server V1.0 for DOS" by SynOptics Communications, Inc. [5 pages] (Sep. 1, 1991).
- "Lattis EZ-View" by SynOptics Communications, Inc. [19 pages] (Date: Unknown).
- "LattisEZ-View Version 2.0" by SynOptics Communications, Inc. [6 pages] (Nov. 9, 1992).
- "LattisNet Manager for UNIX 2.0", SynOptics Communications, Inc., Product Announcement [18 pages] (Sep. 23, 1991).
- LattisNet Model 505 Transceiver Quick Reference Sheet (893-448-A), (date unknown), 2 pages.
- LattisNet Model 505 Unshielded Twisted Pair Transceiver (Pictures), (date unknown), 5 pages.
- "LattisNet Model 822 10BASE-T-To-Type 1 Adapter Reference Sheet" by SynOptics Communications, Inc., # 893-029 [6 pages] (Date: Unknown).
- LattisNet Model 3305 Ethernet UTP Host Module (Pictures), (date unknown), 8 pages.
- "LattisNet Model 3323S and 3324-ST High-Speed Local Ethernet Bridges" by SynOptics Communications, Inc. [11 pages] (Mar. 4, 1991).
- "LattisNet Model 3386 Remote Ethernet Router" by SynOptics Communications, Inc. [16 pages] (Mar. 4, 1991).
- LattisNet System 3000 Ethernet Connectivity Guide, SynOptics Communications, Inc., Sep. 1991, 19 pages.
- LattisNet System 3000 Ethernet Connectivity Guide, Sep. 1991, 7 pages.
- LattisNet System 3000 Ethernet Connectivity Guide, SynOptics Communications, Inc., Sep. 1991, 12 pages.
- LattisNet System 3000 Ethernet Connectivity Guide, Sep. 1991, 19 pages.
- Lavoisard, J.L., et al., Les Installations Terminales D' Abonnes, Com-mutation & Transmission No. 3, 1987, pp. 35-50.
- Lebar, M.K.; Sarles, F.W.; "A Low Cost Integratable Solution for FDDI Signaling Over Twisted Pair", National Semiconductor & Cabletron Systems, (Jun. 1991).
- Lebar, Michael Kip; Sarles, F. Williams and Polhemus, Gary, "FDDI—Shielded Twisted Pair and Data Grade Unshielded Twisted Pair Physical Layer Medium Dependent—(STP/DTP-PMD)—Draft Proposal", Cabletron Systems, Inc., FWS Engineering and National Semiconductor, (Aug. 15, 1991).
- Letter of Assurance Process Flowchart, IEEE, 2 pages.
- Levine, Judith, FDDI Spec Consortium, 21 pages.
- Local Area Networks, Managing the Physical Layer, International Data Corporation, Mar. 1990, 36 pages.
- Local Area Network Station Connector (IBM Technical Disclosure Bulletin, vol. 27 No. 2) by E.J. Annunziata and T.E. Stammely [5 pages] (Jul. 1984).
- Local Networking Article: "Interoperability top priority for vendors" by Susan Breidenback [2 pages] (Jun. 18, 1990).
- Lucent Technologies, "Merlin® Plus Communications System—Release 2—System Manual," 999-507-148, Issue 3, Aug. 1990, 337 pages.
- Lucent Technologies, "Merlin® Plus Communications System," Release 2, Customization Chart, 999-503-148, Issue 3, Nov. 1989, 6 pages.
- Lucent Technologies, "Merlin® Plus Communications System CF/RLA Card," 1989, 999-502-148, Issue 3, 2 pages.
- M&T Publishing, "King Tut Expands Ethernet", LAN Technology, (Nov. 1992).
- M&T Publishing, "Tutankhamon Electronics Inc., The Assistant Network Manager, Cable Diagnostic Tools, Product Announcement", LAN Technology, (Oct. 15, 1992).
- MagicNet Hub (Models: ML 400x & Model 401x) (Pictures), (date unknown), 8 pages.
- "MagicNet Installation Guide" (Jan. 1, 1991).
- Mancour, Tim; "MAC-Less FDDI Concentrator Command Summary" (Mar. 10, 1992).
- Markov, J.D.; Strole, N.C.; "Token-Ring Local Area Networks: A Perspective", International Business Machines Corporation, (1982).
- Mazzola, Mario, "Evaluating PR-4 as a FDDI / UTP PMD Coding Scheme", Crescendo Communications, Inc., (Feb. 19, 1991).
- "Medium Attachment Unit and baseband medium specifications, type 10BASE5" (IEEE 802.3-1985 within IEEE Std 802.3, 2000 Edition).
- "Medium attachment unit and baseband medium specifications, type 10BASE2" (IEEE 802.3a within IEEE 802.3 2000 Edition).
- Mercier, et al., "Los Alamos National Laboratory's High-Performance Data System," (Sep. 1991), 4 pages.
- Mercier, et al. "NFS as a User Interface to a High-Performance Data System," (Oct. 1991), 9 pages.
- "Merlin 206, 410, 820 & Plus—Classic Mail Design Package 1.6—Site Survey," (Date Unknown), 21 pages.
- "Merlin 206, 410, 820 & Plus—Classic Mail Design Package—Site Survey," (Date Unknown), 22 pages.
- Miligan, Gene; Ross, Floyd; Cooper, Stephen W.; Ater, Dan; "FDDI—Metallic Media—Unshielded Twisted Pair Physical Layer Medium Dependent (UTP-PMD)—Draft Proposed American National Standard" (Jun. 10, 1991).
- "Minutes of Jun. 20 & 21, 1990 Meeting" by ASC Task Group X3T9.5, [3 pages] (Jun. 20/21, 1990).
- "Minute—the Aug. 20, 1991 TP-PMD Meeting. Boulder, Colorado" by Author Unknown [2 pages] (Aug. 20, 1991).
- Model 505 Chip Transceiver Schematic [3 pages] (Jun. 27, 1988).
- "Model 2722 Local Token Ring Bridge" by SynOptics Communications, Inc. [10 pages] (Nov. 9, 1992).

(56)

References Cited

OTHER PUBLICATIONS

- "Model 2800 10BASE-T Workgroup Concentrator—New Version of the Model 2800 10BASE-T Workgroup Concentrator Offers Greater Value" by SynOptics Communications, Inc. [2 pages] (Oct. 24, 1991).
- National Semiconductor Corporation, "DP83220 CDL Twisted Pair FDDI Transceiver Device" Advance Information (Oct. 1992).
- Network World, Spec Details Use of FDDI Over Shielded Twisted Pair (May 27, 1991).
- "Network World—The Newsweekly of User Networking Strategies", vol. 7, No. 46 [78 pages] (Nov. 12, 1990).
- Network World Article: "Coalition forming to advance FDDI on UTP" [2 pages] (Jul. 15, 1991).
- Network World Article: "DEC to show new FDDI, E-mail wares" [2 pages] (Jan. 28, 1991).
- Network World Article: "Proposed groups eye alternate FDDI media" [3 pages] (Nov. 12, 1990).
- Network World Article: "Start-up offers FDDI adapters for shielded twisted-pair local nets" [8 pages] (Jun. 10, 1991).
- Network World Article: "SynOptics supports FDDI over shielded twisted pair" [1 page] (6-18-91).
- Network World Article: "SynOptics supports FDDI over shielded twisted pair" [1 pages] (Jun. 18, 1990).
- Network World Article: "SynOptics to unveil FDDI components" [2 pages] (Aug. 19, 1991).
- Network World Article: "SynOptics touts FDDI products affordability" [2 pages] (Sep. 2, 1991).
- Network World Article: "Token-ring sales take off" [3 pages] (Aug. 17, 1987).
- Newsbytes, "3Com Shows a Bevy of New Products at InterOp" (May 20, 1992).
- Newsbytes, "Tutankhamon Electronics Intros MagicNet LAN" (Nov. 7, 1991).
- "Old-Time Telephones! Design, History and Restoration" {Book} (Author: Ralph O Meyer, A Schiffer Book With Price Guide for Collectors, 2005).
- Original Style Phone (6 Pictures) {Date Unknown}.
- Pages from FDDI Articles: 1) "SynOptics touts FDDI products' affordability" by Network World, page No. 4, Sep. 9, 1991, 2) "The copper connection to FDDI" by Network World, page No. 36, Dec. 16, 1991, 3) "Coalition forming to advance FDDI on UTP" by Network World, page No. 1, Jul. 15, 1991, 4) Proposed groups eye alternate FDDI media by Network World, page No. 121, Nov. 12, 1990, 5) "SynOptics supports FDDI over shield twisted pair" by Network World, page No. 23, Jun. 18, 1990, 6) "SynOptics touts FDDI product's affordability" by Network World, page No. 4, Sep. 9, 1991, 7) "SynOptics supports FDDI over shielded twisted pair" by Network World, page No. 23, Jun. 18, 1990, 8) "Spec details use of FDDI over shielded twisted-pair" by Network World, page No. 2, May 27, 1991, 9) "IBM support bolsters FDDI cabling spec" by Network World, page No. 9, Sep. 16, 1991, 10) "Start-up offers FDDI adapters for shielded twisted-pair local nets" by Network World, page No. 6, Jun. 10, 1991, 11) "SynOptics to unveil FDDI components" by Network World, page No. 1, Aug. 19, 1991, 12) "Firms integrate efforts" by Network World, page No. 56, May 27, 1991, 13) "FDDI on unshielded wire to be topic as ANSI meet Group to hear presentations backing technology" by Network World, page No. 4, Jun. 17, 1991, 14) "DEC to show new FDDI, E-mail wares" by Network World, page No. 1, Jan. 28, 1991.
- "PairGain Extends HDLS2 Product Leadership, Announces HDLS2 Product Availability; HiGain Solitaire: Truly Interoperable HDLS2 Solutions for T1 Access," by PairGain Technologies, Inc., (1999), Business Wire, 3 pages.
- PairGain Technologies HiGain-2 Remote Unit, Model HRU-612 by PairGain Technologies, Inc.—Section 150-612-102—Rev. 03, (Jan. 30, 1996), 19 pages.
- PairGain Technologies HiGain-2 Remote Unit, Model HRU-612 by PairGain—Section 150-612-100—Rev. 02, (Aug. 21, 1996), 19 pages.
- PairGain Technologies HiGain Doubler Unit Model HDU-451, Issue 1, List 3B—Section 150-451-132-01—Rev. 2, (Nov. 13, 1997), 22 pages.
- PC Week, "4 Vendors' FDDI Managers Pass Interoperability Tests" (Feb. 17, 1992).
- PC Week, "ANSI Rejects Plan for Alternate FDDI Media" (Oct. 28, 1991).
- PC Week, "Companies Pool Proposals for Copper-Based FDDI Network Standard" (Jun. 29, 1992).
- PC Week, "Digital Leads Drive to Twisted-Pair FDDI" (May 27, 1991).
- PC Week, "FDDI Vendors Hope to Stir Market With Hubs, Cards" (May 25, 1992).
- PC Week, "Group Proposes New FDDI Wiring Scheme: UTP Solution Would Slash Costs" (Aug. 5, 1991).
- PC Week, "Microdyne Introduces 100M-bps FDDI board" (Dec. 9, 1991).
- PC Week, "Vendor Eyes FDDI Adapter Support for Twisted Pair" (Jun. 10, 1991).
- Perspective Computer Systems News Article—Making Sure the Pieces Fit [7 pages] (Mar. 1988).
- "Physical Coding Sublayer (PCS), Physical Medium Attachment (PMA) sublayer and baseband medium, type 100BASE-T4" (within IEEE 802.3u within IEEE Std 802.3, 1998 Edition).
- "Physical signaling, medium attachment, and baseband medium specifications, type 1 BASE5" (IEEE 802.3e-1987 within IEEE Std 802.3, 2000 Edition).
- Picture (Drawing) of FDDI/Twisted Pair Adaptor Card (Author Unknown) (Date: Unknown).
- Platt, R., "New Standard Helps Multimedia Get Off the Ground," (Summer 1996), IEEE Multimedia, vol. 3, No. 2, pp. 78-82.
- Platt, R., "Why IsoEthernet Will Change the Voice and Video Worlds," (Apr. 1996), IEEE Communications Magazine, vol. 34, No. 4, pp. 55-59.
- "Prepare Ye the Way: Install Cable Now for Data Transmissions of Tomorrow" (Communications Week) {Date Unknown}.
- Product and Price Schedule (SynOptics, Inc.—p. 18 of 25) [1 page] (Aug. 1, 1991).
- "Project Proposal" by Chipcom Corporation, [146 pages] (Oct. 17, 1989).
- Pulse Engineering Inc., "10BASE T and Ethernet Surface Mount Transformers" (Jun. 1991).
- Reddy, "Traffic Control: network monitors keep your LAN from going south," The Local Area Network Magazine, (May 1990), pp. 76(7).
- Reference Data for Engineers: Radio, Electronics, Computer and Communications, 1989, 17 pages.
- Rissow, Beverly; Johnson, Beth, "SynOptics Signs Technology Agreements to Speed the Development of Twisted Pair FDDI Products—CMC, Interphase, Network Peripherals and Silicon Graphics Join SynOptics in Effort to Reduce Cost of FDDI to the Desktop", Press Release (Sep. 24, 1990).
- Ross, F., et al., "IsoEthernet: An Integrated Services LAN," (Aug. 1996), IEEE Communications Magazine, vol. 34, Issue 8, pp. 74-84.
- Ross, Floyd E., "FDDI—A 100 Megabit Per Second Local Area Network" Timeplex—Systems Engineering (Jul. 1991).
- Schmidt, Dr. Ronald V., "Developing Ethernet Capability on Unshielded Twisted Pair", Telecommunications, (Jan. 1988).
- Schommer, Nick; Vogt, Jim, SynOptics Company, "FDDI Workgroup Hub Project Proposal" (Jan. 21, 1991).
- Second Style Phone (3 Pictures) {Date Unknown}.
- See, Michael, "Transmission—The IBM Token Ring Will Handle Up to 72 Stations at the Full 4-Mbit/s Data Rate" IBM Corp., Data Communications, (Mar. 1986).
- Shah, Amit; Staddon, Don; Rubin, Izhak; Ratkovic, Aleksandar, "Multimedia Over FDDI", Conference Paper Reprint (Sep. 13, 1992).
- Smith, Tom, "Chipcom's Wire Hub Boasts Support for Range of LANs", Network World, vol. 7, No. 4, (Feb. 5, 1990).
- SonePlex Wideband System 3190—Installation and Verification Guide by ADC—Section 800-357-104-01—Rev. 1, (Sep. 2000), 112 pages.
- Stallings, William, Local Networks, An Introduction.

(56)

References Cited

OTHER PUBLICATIONS

- Stallings, William, *Local Networks* (Second Edition), 435 pages.
- Stewart, Mary, "Chipcom Unveils Twisted Pair/FDDI Technology", Press Release, (Jun. 14, 1990).
- Stewart, Mary, "Chipcom Unveils Twisted Pair/FDDI Technology", Press Release, Chipcom, (Jun. 14, 1990).
- "STP Proposal—Introduction" by AMD, Chipcom, DEC, IBM, Motorola, SynOptics [60 pages] (Oct. 15, 1991).
- Strole, Norman C., "The IBM Token Ring Network—A Functional Overview" *IEEE Network Magazine*, vol. 1, No. 1, pp. 23-30 (Jan. 1987).
- "Subscriber Loop Signaling and Transmission Handbook—Analog" {Book} (Author: Whitham D. Reeve, IEEE Press, 1992).
- SynOptics Communications, Inc., "10BASE-T Host Modules, Transceivers and Network Interface Cards", Internal Product Announcement (Feb. 15, 1990).
- SynOptics Communications, Inc., "2700 Series Token Ring Workgroup Hubs", Product Announcement (May 5, 1992).
- SynOptics Communications, Inc. "Designing Highly Available FDDI Backbone Networks", Application Note (Mar. 25, 1992).
- SynOptics Communications, Inc., "Ethernet Switching Engine (ESE)", Product Directions (Jun. 8, 1992).
- SynOptics Communications, Inc., "FDDI Networking on Twisted Pair", Version 0.2 (Date Unknown).
- SynOptics Communication, Inc., "FDDI—UTP—Investigation", (Date Unknown).
- SynOptics Communications, Inc., "IBM and SynOptics Business Alliance Update", Sales Note, (Feb. 24, 1992).
- SynOptics Communications, Inc., "Internetworking Product Directions Announcement", Product Directions, (Mar. 4, 1991).
- SynOptics Communications, Inc., "Lattis EZ-View" IS505-036US-A (Date Unknown).
- SynOptics Communications, Inc., "Lattis EZ-View Version 1.1" Product Update, (Aug. 28, 1992).
- SynOptics Communications, Inc., "Lattis EZ-View Version 2.0", Product Update, (Nov. 9, 1992).
- SynOptics Communications, Inc., "LattisHub 10BASE-T Workgroup Hubs", Product Announcement (Oct. 5, 1992).
- SynOptics Communications, Inc., "LattisLink 2800A 10BASE-T Workgroup Concentrator Users Guide" (Aug. 1992).
- SynOptics Communications, Inc., "LattisNet Basic Network Management for Ethernet and Token Ring", Product Announcement, (Mar. 4, 1991).
- SynOptics Communications, Inc., "LattisNet Basic Network Management Version 3.1", Internal Product Announcement (Jan. 21, 1991).
- SynOptics Communications, Inc., "LattisNet Ethernet Bridge Manager", Product Announcement (Dec. 6, 1991).
- SynOptics Communications, Inc., "LattisNet Manager for DOS 4.2", Product Update (Aug. 28, 1992).
- SynOptics Communications, Inc., "LattisNet Model 955 & Model 956 Token Ring Integrated Media Filters for Unshielded Twisted Pair Lobe Connection", Product Announcement, (Nov. 4, 1991).
- SynOptics Communications, Inc., "LattisNet Model 3000-04-R Concentrator With Redundant Power Supplies", Product Announcement, (Mar. 4, 1991).
- SynOptics Communications, Inc., "LattisNet Product Overview" (Apr. 1990).
- SynOptics Communications, Inc., "LattisNet Product Overview—A Comprehensive Description of the LattisNet Product Family" (Date Unknown).
- SynOptics Communications, Inc., "LattisSecure and the Model 3368 10BASE-T Host Module", Product Summary (Mar. 2, 1992).
- SynOptics Communications, Inc., "LattisSwitch System 3000 Network Management", Product Update (Oct. 16, 1992).
- SynOptics Communications, Inc., "LattisSwitch System 3000", Product Announcement (Jun. 8, 1992) (pp. 1-23 of 25).
- SynOptics Communications, Inc., "LattisTalk Model 3394 Router / Repeater", Product Announcement (Apr. 20, 1992).
- SynOptics Communications, Inc., "Lattis Views Network Management Solutions", Product Announcement (Apr. 27, 1992).
- SynOptics Communications, Inc., "Low-Cost 10BASE-T Connectivity Products", Product Update Announcement, (May 23, 1990).
- SynOptics Communications, Inc., "Model 27x2 Token Ring Workgroup Concentrators", Product Announcement (Nov. 9, 1992).
- SynOptics Communications, Inc., "Model 505 Unshielded Twisted Pair Transceiver" *Circuit Design* (Jun. 27, 1988; Jan. 17, 1990—9 Pages).
- SynOptics Communications, Inc., "Model 508A 10BASE-T Transceiver", Product Announcement, (Jan. 14, 1991).
- SynOptics Communications, Inc., "Model 518 10BASE-T Transceiver for Apple Ethernet", Product Announcement, (Jan. 16, 1991).
- SynOptics Communications, Inc., "Model 550B UTP Token Ring Lobe Media Filter", Product Announcement (Oct. 19, 1992).
- SynOptics Communications, Inc., "Model 955 & Model 956 Token Ring Integrated Media Filters" Product Announcement (Nov. 4, 1991).
- SynOptics Communications, Inc., "Model 2800 10BASE-T Workgroup Concentrator", Product Update (Oct. 24, 1991).
- SynOptics Communications, Inc., "Model 2810-04 Features 'Local Load' Capability & Advanced LNMS Agent" Product Update (Aug. 15, 1991).
- SynOptics Communications, Inc., "Model 3301-75/3301-93 Ethernet Host Modules", Product Announcement (Dec. 30, 1991).
- SynOptics Communications, Inc., "Model 3307 50-Pin 10BASE-T Host Module" Product Announcement, (Nov. 9, 1990).
- SynOptics Communications, Inc., "Model 3307HD 10BASE-T Host Module", Product Announcement (Dec. 11, 1992).
- SynOptics Communications, Inc., "Model 3313A & Model 3314A Ethernet Network Management Modules", Product Announcement (Oct. 19, 1992).
- SynOptics Communications, Inc., "Model 3502B Token Ring Host Module", Product Announcement (Nov. 9, 1992).
- SynOptics Communications, Inc., "Model 3505A Unshielded Twisted Pair Host Module", Product Announcement (Nov. 11, 1991).
- SynOptics Communications, Inc., "Model 3513 Token Ring Network Management Module", Product Announcement (May 5, 1992).
- SynOptics Communications, Inc., "Phase II LattisNet Token Ring Products Include High Performance Support for Unshielded Twisted Pair Wire at 4 Mb/s & 16 Mb/s, Up to 144 Stations on a Single Ring," Product Announcement (Aug. 27, 1990).
- SynOptics Communications, Inc., "Shielded Twisted Pair Token Ring Modules, Patch Cables and System 3000 Ethernet / Token Ring Concentrators", Product Announcement, (Mar. 19, 1990).
- SynOptics Communications, Inc., "SynOptics FDDI Solution" (Date Unknown).
- SynOptics Communications, Inc., "SynOptics Introduces the Industry's Most Powerful and Complete FDDI Solution", Product Announcement (Jul. 30, 1991).
- SynOptics Communications, Inc. "SynOptics Readies Twisted Pair FDDI Technology for Presentation at ANSI Meeting This Month", News Release, (Jun. 11, 1990).
- SynOptics Communications, Inc., "SynOptics' System 2000 Featuring the Model 2810", Product Announcement, (Feb. 12, 1991).
- SynOptics Communications, Inc., "System 3000 FDDI Host Module—Functional Specification" (Apr. 19, 1991).
- SynOptics Communications, Inc., "System 3000 Network Configuration", Management, Interconnectivity, Technical Support Training (Date Unknown).
- SynOptics Communications, Inc., "Systems 2000 10BASE-T Concentrators", Product Announcement, (Sep. 14, 1990).
- SynOptics Communications, Inc., "The Importance of FDDI Interoperability", Sales Note, (Aug. 14, 1990).
- SynOptics Communications, Inc., "The Inside Story About Twisted Pair FDDI Technology", Technology Update, (Jun. 29, 1990).
- SynOptics Communications, Inc., "The Model 2810 and SynOptics' Value Added", (Date Unknown).
- SynOptics Communications, Inc., "Token Ring Network Management Agent 4.1", Product Update (Aug. 28, 1992).
- SynOptics Communications, Inc., "Token Ring Tutorial", (Jan. 1990).

(56)

References Cited

OTHER PUBLICATIONS

- SynOptics Communications, Inc., "TP-PMD Adaptation for STP Cable Plants" (Apr. 26, 1994).
- SynOptics Communications, Inc., "What is FDDI's Station Management (SMT)?", Sales Note, (Oct. 16, 1990).
- "SynOptics Distributes LAN Management" by LAN Magazine [4 pages] (May 1991).
- "SynOptics Distributes LAN Management" (LAN Magazine, May 1991).
- SynOptics LattisNet System 3000 Ethernet Connectivity Guide, (Sep. 1991), p. 4-2.
- SynOptics Series 3000 Hub Management Module Guide, Feb. 1998.
- "SynOptics supports FDDI over shielded twisted pair" by Local Networking [2 pages] (Jun. 18, 1990).
- System Consideration for Multisegment 10 Mb/s Baseband Networks, (Section 13) and Twisted Pair Medium Attachment Unit (MAU) and Baseband Medium, Type 10BASE-T (Section 14), 33 pages.
- TCL Incorporated, "Ethernet / IEEE 802.3 Installation Tester—The TCL Installation Tester Model 2011" (1986).
- TCL Incorporated, "Ethernet / IEEE 802.3 Segment to Segment Connection—The TCL Repeater Model 2210" (1987).
- TCL Incorporated, "The Connection to Ethernet—Transceiver or MAU Models 2010EB, 2010EBS, 2010I & 2010IS" (1987).
- TCL Incorporated, "The Connection to Ethernet / IEEE 802.3 Local Area Networks—Transceiver or MAU Model 2010DM" (1988).
- TCL Incorporated, "The Multiconnection to Ethernet Versions 1 & 2, and IEEE 802.3—The Dual-Mode Multiport Transceiver Model 2110-DM" (1988).
- TCL Incorporated, "The Multiconnection to Ethernet / IEEE 802.3—The TCL Multiport Transceiver Model 2110" (1987).
- T.H.E. Journal, "School Buildings Linked Via Existing Phone Wire" (May 1992).
- Technical Committee X3T9, "FDDI STP-PMD Proposal" I/O Interface (Date Unknown).
- Technical Report—"Issues in LAN Switching and Migration from a Shared LAN Environment" by Rich Seifert (Networks and Communications Consulting) [28 pages] (Nov. 1995).
- Technical Report—"The Effect of Ethernet Behavior on Networks using High-performance Workstations and Servers" by Rich Seifert (Networks and Communications Consulting) [25 pages] (Mar. 3, 1995).
- Technical Response Center, Technical Tip, Bay Networks, 2 pages.
- Telecommunications Industry Association, "Electrical Characteristics of Generators and Receivers for Use in Balanced Digital Multipoint Systems" TIA Standard, TIA-485-A (Mar. 1998).
- "Telephones—Antiques to Modern" {Book} (Author: Kate E. Dooner, A Schiffer Book for Collectors, 1997).
- The Ethernet, A Local Area Network, Data Link Layer and Physical Layer Specifications, Version 1.0, Sep. 30, 1980.
- The Ethernet, A Local Area Network, Data Link Layer and Physical Layer Specifications, Version 2.0, Nov. 1982.
- "The Ethernet evolution" (The Network Report, Jan. 1992).
- The Institute of Electrical and Electronics Engineers, "IEEE Standard Digital Interface for Programmable Instrumentation", ANSI/IEEE Std 488-1978; Revision of ANSI/IEEE Std 488-1975—Includes Supplement IEEE Std 488A-1980 (Jun. 9, 1978).
- The LOCALNetter Newsletter: "Special Report—SynOptics Networking Products", vol. 9, No. 10 [6 pages] (Oct. 1989).
- "The SUPERNET® Family for FDDI—1991/1992 World Network Data Book" by Advanced Micro Devices, [114 pages].
- "The SUPERNET® Family for FDDI—Technical Manual" by Advanced Micro Devices, [112 pages] (Jul. 1989).
- "The Use of Scramblers with Anti Locking Circuit" by Michael P. Spratt, Hewlett Packard [16 pages] (Dec. 6, 1991).
- Third Style Phone (1 Picture) {Date Unknown}.
- Thorngate, Kristina, "SynOptics Introduces Industry's Most Powerful FDDI Solution" (Sep. 9, 1991).
- "TIA/EIA-568-A"—"Commercial Building Telecommunications Cabling Standard" (Oct. 6, 1995).
- "TIA/EIA-568-A-1"—"Propagation Delay and Delay Skew Specifications for 100 ohm 4-Pair Cable" (Aug. 20, 1997).
- "TIA/EIA-568-A-2"—"Corrections and Additions to TIA/EIA-568-A" (Jul. 28, 1998).
- "TIA/EIA-568-A-3"—"Addendum No. 3 to TIA/EIA-568-A" (Dec. 10, 1998).
- "TIA/EIA-568-A-4"—"Production Modular Cord NEXT Loss Test Method and Requirements for Unshielded Twisted-Pair Cabling" (Nov. 29, 1999).
- "TIA/EIA-568-A-5"—"Transmission Performance Specifications for 4-Pair 100 ohm Category 5e Cabling" (Jan. 27, 2000).
- "Token Ring Access Method," The Institute of Electrical and Electronics Engineers, Inc., 1985, 80 pages.
- Token Ring Network Architecture Reference, IBM, 15 pages.
- Token-Ring Network—Architecture Reference, # SC30-3374-02 [485 pages] (Sep. 1989).
- Track-It for Windows, 3 pages.
- "Tutankhamon Electronics, Inc. Presents: MagicNet" {Date Unknown}.
- "Tut Claims 155Mbps on Cat 3 Cable" (LAN Times, Jan. 9, 1995).
- "Tut Systems Announces Localtalk-To-Ethernet Printer Solution for Silver Streak Product Family" (Tut System News, Nov. 2, 1994).
- "Tut Systems Announces parallel Port Ethernet Connector That Makes Networking a Snap for Mobile and Desktop Users" (Tut System, Nov. 2, 1994).
- "Tut Systems Announces Partnership With E/O Networks That Will Marry High-Speed Copper to Fiber Telephony Infrastructure" (Tut System, Dec. 12, 1994).
- "Tut Systems Appoints New President to Expand Opportunities for Company's Technology" (Tut System News, Nov. 2, 1994).
- "Tut Systems Brings ATM to Desktops With Revolutionary Fast Copper Technology Converter and PMD Transceiver" (Tut System, Jul. 11, 1995).
- "Tut Systems Company Background" {Date Unknown}.
- "Tut Systems Cuts the Cost of High-Speed Networking for Education Community" (May 24, 1994).
- "Tut Systems Introduces Industry-Standard PCMCIA Ethernet Card for Portables" (Tut System News, Nov. 2, 1994).
- "Tut Systems Receives Byte Magazine's Award of Distinction" (Tut Systems, Jan. 3, 1994).
- Tut Systems "Technical Overview" {Date Unknown}.
- "Tut Transceivers Target Telcos, ATM" (Electronic News) {Date Unknown}.
- "UB Networks and Tut Systems Bring the First Implementation of ATM to Desktop at 155Mbps Over UTP/3" (Tut System, Jan. 23, 1995).
- "UB signs up Tut for ATM on copper" (MacWeek, Jan. 30, 1995).
- "UB, Tut, ODS prep high-speed LAN Gear" (Network World, Jan. 23, 1995).
- Understanding Token Ring Protocols and Standards by James T. Carlo, Robert D. Love, Michael S. Siegel and Kenneth T. Wilson—Artech House [4 pages] (1998).
- Universal Serial Bus Specification, Revision 1.1, Sep. 23, 1998, 327 pages.
- "Universal Service Ordering Codes" (pp. 47-57) {Date Unknown}.
- Using the IBM Cabling System with Communication Products, # GA27-3620-1 [355 pages] (Apr. 1986).
- Valor, "Ethernet / Cheapernet Lan Coupling Transformers" (Oct. 1989).
- Van-Mierop, "Extending Ethernet/802.3 Over FDDI Using the FX 8000," High Speed Local Area Networks, II, Elsevier Science Publishers B. V. (North-Holland), IFIP (1990), pp. 259-267.
- Visual Audit Pro, 2 pages.
- Vox Technologies—ADTRAN D448N ISDN CU—1430020L1—D448 ISDN CU (Date Unknown), 1 page.
- Warner, Jamie, Chipcom Corporation, "FDDI—TPDDI White Paper" (Sep. 19, 1991, Version 1.2).
- Warner, Jamie, "FDDI—TPDDI White Paper", Chipcom Corporation, Version 1.2, (Sep. 19, 1991).
- Wekler, Joanie M., "Don't Yank Those Wires Out Just Yet" Computer World, (Jun. 18, 1990).
- Wireline Service Delivery Products, First Edition, ADC, (Sep. 2004), 18 pages.

(56)

References Cited

OTHER PUBLICATIONS

- Worldwide History of Telecommunications by Anton A. Huurdeman [38 pages] (No date).
- "You Haven't Heard the Last of 'Dirty, Noisy' Copper" (America's Network, Jan. 16, 1997).
- Yount, "Security Monitor for Office Equipment," IBM Technical Disclosure Bulletin, vol. 24, No. 1B, (Jun. 1981), pp. 576-577.
- ZD Net, "Bucking the Trend: A Low-Cost Ethernet LAN", Computer Shopper, (Oct. 1991).
- U.S. Appl. No. 13/615,726, filed Sep. 14, 2012, Austermann.
- U.S. Appl. No. 13/615,734, filed Sep. 14, 2012, Austermann.
- U.S. Appl. No. 13/615,755, filed Sep. 14, 2012, Austermann.
- 3Com—Discontinued Pro—Products List, (date unknown), 8 pages.
- 3Com, OfficeConnect Remote Getting Started Guide, (Sep. 1997), 71 pages.
- 3Com—The 3Com NETBuilder Router product line has been placed on End of Life Notice, (date unknown), 8 pages.
- ADC Telecommunications, Homeworx Access Platform, (date unknown), 11 pages.
- ADC Telecommunications, Homeworx Access Platform Telephony System, (date unknown), 7 pages.
- ADC Telecommunications, News Release, "ADC, ALS Demo Homeworx HFC at CableNET '94—System Brings Broadband to Residential and Small-Business Users," (Nov. 30, 1994), 1 page.
- ADC Telecommunications, Inc., Homeworx Access Platform—Overview, (Nov. 1997), 5 pages.
- ADC Telecommunications, Inc., Telephony/Video Over Hybrid Fiber/Coax Network, (date unknown), 4 pages.
- AT&T Data Sheet, LB1019AB Power Controller, (Sep. 1986), 15 pages.
- AT&T, Definity Communications System and System 75 and System 85 DS1/DMI/ISDN-PRI Reference, AT&T 555-025-101, Issue 4, (Apr. 1990), 396 pages.
- AT&T, Definity Communications System Generic 2 and System 85 7407 Plus Voice Terminal User's Guide, Document No. 555-104-742, Issue 1, (Jul. 1991), 46 pages.
- AT&T, Definity Communications System Generic 2 ISDN 7505, 7506, and 7507 Terminals User's Guide, Document No. 555-104-719, Issue 1, (Oct. 1989), 57 pages.
- AWC Video/Telephony Solution, (date unknown), 1 page.
- Abramson, P., "Design of a Twisted-Pair Cable for a Local Area Network," International Business Machines Corporation 1986, Document No. GA27-3732-0, Part No. 61X3816, 2 pages.
- Abramson, P., "Local Area Network Media: Copper or Optical Fiber?" International Business Machines Corporation 1986, Document No. GA27-3732-0, Part No. 61X3816, 2 pages.
- ADTRAN, HDLS T200 HTU-R, Span Powered, 60 mA, Installation and Maintenance Practice, (Apr. 2008), 50 pages.
- Alcatel, 1000 ADSL High Speed Modem User's Guide, (1999), 92 pages.
- Allen, J. E., "Network Management of a Local Area Network," International Business Machines Corporation 1986, Document No. GA27-3732-0, Part No. 61X3816, 3 pages.
- Allied Telesyn—AT-MC101XL, AT-MC102XL, AT-MC103XL, AT-103LH—Fast Ethernet Media Converters—Installation Guide, PN 613-10771-00 Rev. C, (1999), 28 pages.
- Allied Telesyn, AT-MC101XL, AT-MC102XL, AT-MC103XL, AT-MC103LH, AT-MC103SC/FS3, FS4, AT-MC103ST/FS3, FS4—Version 3 Fast Ethernet Media Converters—Installation Guide, PN 613-10771-00 Rev. D, (2000), 48 pages.
- American Lightwave Systems, Inc., Homeworx Video—Forward Path Headend Transmitter, (date unknown), 2 pages.
- American Lightwave Systems, Inc., Homeworx Video—ISX Series Optical Station, (date unknown), 2 pages.
- American Lightwave Systems, Inc., Homeworx Video—Reverse Path QUAD Receiver, (date unknown), 2 pages.
- American National Standard for Telecommunications—Network and Customer Installation Interfaces—Asymmetric Digital Subscriber Line (ADSL) Metallic Interface, ANSI T1.413-1998, (Nov. 11, 1998), 264 pages.
- An Advanced Voice Services Platform for the Catalyst 5000 System—A Unified Market Focus/Market Requirements/System Architecture Document, Note N.90, Rel. 2.0, (Jul. 31, 1998), 49 pages.
- Andrews, D. W., and Munn, J. E., "Overview of Logical Link Control," International Business Machines Corporation 1986, Document No. GA27-3732-0, Part No. 61X3816, 3 pages.
- Bailey, W. D., "Functional Verification of a Local Area Network," International Business Machines Corporation 1986, Document No. GA27-3732-0, Part No. 61X3816, 2 pages.
- Bates, R.J.S., et al., "Four-Megabit-Per-Second Data Transmission on Telephone Twisted-Pair," International Business Machines Corporation 1986, Document No. GA27-3732-0, Part No. 61X3816, 4 pages.
- Bederman, S., "Source Routing for Complex Networks," International Business Machines Corporation 1986, Document No. GA27-3732-0, Part No. 61X3816, 2 pages.
- Bell Globemedia Publishing Inc., The Globe and Mail (Canada)—"Nortel sells system in U.S.—Allows phone calls over cable TV," (Feb. 28, 1995), 2 pages.
- Bell System, Coin Service Manual, vol. II, (Oct. 1975), Part 1, 182 pages.
- Bell System, Coin Service Manual, vol. II, (Oct. 1975), Part 2, 182 pages.
- Bell System, Coin Service Manual, (Dec. 1973), Part 1, 325 pages.
- Bell System, Coin Service Manual, (Dec. 1973), Part 2, 326 pages.
- Bell System, Coin Crafts' Manual, (Aug. 1978), 162 pages.
- Bernier, P., "Northern Telecom joins HFC bandwagon," Telephony, (Nov. 21, 1994), p. 10.
- Bevill, B., "Baluns for the IBM Token-Ring Network," International Business Machines Corporation 1986, Document No. GA27-3732-0, Part No. 61X3816, 2 pages.
- Black Box Corporation, Network Services and Equipment from the Leader in LANs—The LAN Catalog from Black Box Corporation, (Winter 1989), 68 pages.
- Bland, W. M. and Jeffrey, E. M., "Grounding Requirements for Devices Attaching to the IBM Token-Ring Network," International Business Machines Corporation 1986, Document No. GA27-3732-0, Part No. 61X3816, 3 pages.
- Broadband Products—Dual-Cable Availability, Cost-Effective Direct PC Connections Announced, Chipcom Connections, vol. I, No. 3, (Oct. 1988), p. 2.
- Business Wire, Inc.—Advanced Computer Communications and West End partner to enhance broadband access product line, (Jun. 4, 1996), 2 pages.
- Bux, W., and Pitt, D., "Dynamic Window Flow Control for Interconnected Token Rings," International Business Machines Corporation 1986, Document No. GA27-3732-0, Part No. 61X3816, 3 pages.
- CMS Technologies—EtherLock II, (1998), 1 page.
- CMS Technologies—EtherLock II Product Family (EtherLock Security Systems, EtherLock II, LockSoft Software, EtherLock ID), (1998), 1 page.
- CMS Technologies—EtherLock II Product Family, (1998), 1 page.
- Canada NewsWire Ltd.; Canada NewsWire—"Northern Telecom Announces New Hybrid Fiber/Coax Products," (Nov. 14, 1994), 2 pages.
- Canada NewsWire Ltd.; Canada NewsWire—"Northern Telecom Selected for Cablevision Systems Telephony Trial," (Feb. 22, 1995), 2 pages.
- Canada NewsWire Ltd.—"Northern Telecom (Nortel) to Market Com21 Cable Modems with Cornerstone Voice," (Dec. 4, 1996), 2 pages.
- Canary Communications, Fast Ethernet Converters, (Apr. 1999), 2 pages.
- Canary Communications, Fast Ethernet Converters, (1999), 2 pages.
- Canary Communications, Fast Ethernet Converter Specifications, (1999), 2 pages.
- Carey, J., "Connector Design," International Business Machines Corporation 1986, Document No. GA27-3732-0, Part No. 61X3816, 2 pages.
- Carey, J. J., "Installation Testing of IBM Data Cable," International Business Machines Corporation 1986, Document No. GA27-3732-0, Part No. 61X3816, 3 pages.

(56)

References Cited

OTHER PUBLICATIONS

- Cervenka, D., "Building cablephone systems piece by piece—Manufacturers provide an update," *CED: Communications Engineering & Design*, (Mar. 1996), pp. 42-52.
- Chipcom and Allen-Bradley Ink OEM Deal, *Chipcom Connections*, vol. 1, No. 3, (Oct. 1988), p. 2.
- Chipcom, Chipcom Corporation, *History & Highlights*, (date unknown), 5 pages.
- Chipcom, "Dear Editor" Letter, by Pamela Herbert, (Oct. 2, 1989), 1 page.
- Chipcom, *Management Biographies*, (date unknown), 3 pages.
- Chipcom, *Product Backgrounder, Chipcom Fiber Optic Ethernet Products*, (date unknown), 6 pages.
- Chipcom Corporation, *Chipcom Demonstrates Fault-Tolerant Fiber Ethernet at Interop '89—ORnet Fiber Ethernet System Eliminates Network Downtime*, (date unknown), 3 pages.
- Chipcom Corporation *Interop 89 Network*, (date unknown), 1 page.
- Chipcom Corporation, *ORnet Fiber Optic Ethernet Connectivity from Chipcom*, (Jun. 1989), 4 pages.
- Chipcom Corporation, *ORnet/PC Fiber Adapter Card, Fiber Optic Ethernet Connectivity from Chipcom*, (Jul. 1989), 2 pages.
- Chipcom Corporation, *Product Backgrounder—Broadband Local Area Network Products*, (date unknown), 5 pages.
- Chou, J. H., and Jeske, R. G., "Automated Protocol Verification," *International Business Machines Corporation 1986*, Document No. GA27-3732-0, Part No. 61X3816, 2 pages.
- ChriMar Systems, Inc., *EtherLock 10T User's Manual*, (date unknown), 42 pages.
- Cisco Systems, *Catalyst 1900 and Catalyst 2820*, (1996), 3 pages.
- Cisco Systems, *Catalyst 1900 and Catalyst 2820—Data Sheet*, (Oct. 28, 1996), 4 pages.
- Cisco Systems, *Catalyst 1900 and Catalyst 2820 Series Overview—Product Announcement*, (1996), 11 pages.
- Cisco Systems, *Catalyst 1900 and Catalyst 2820 Series Switches—Product Announcement*, (Sep. 11, 1996), 9 pages.
- Cisco Systems, *Catalyst 3000 and Catalyst Matrix*, (1996), 3 pages.
- Cisco Systems, *Cisco 600 Series Installation and Operation Guide*, (Jul. 2000), 192 pages.
- Cisco Systems, *Cisco 675 ADSL Router Installation and Operation Manual, Version 2.0.0.*, (Aug. 1998), 118 pages.
- Cisco Systems, *Cisco 675 SOHO/Telecommuter ADSL Router*, (May 1999), 3 pages.
- Cisco Systems, *Cisco 675e Small Office Home Office/Telecommuter ADSL Router*, (Jun. 1999), 3 pages.
- Cisco Systems, *Cisco 677 SOHO/Telecommuter ADSL Router*, (Oct. 1999), 3 pages.
- Cisco Systems, *Cisco 678 Small Office/Home Office/Telecommuter ADSL Router*, (May 2000), 3 pages.
- Cisco Systems, *CiscoPro EtherSwitch CPW2115*, (1995), 4 pages.
- Cisco Systems, *Data Sheet—Catalyst 3200*, (1996), 3 pages.
- Cisco Systems—"IP Addressing on the Workgroup Catalyst 1200 Series," Document ID: 13787, (Nov. 16, 2005), 3 pages.
- Cisco Systems—"Setting Up MacIP," Document ID: 10679, (Oct. 4, 2005), 7 pages.
- Cisco Systems, *Stackable Catalyst Switch Offers Broad Media Flexibility and Integrated Branch Office Connectivity Solutions—Product Announcement*, (1996), 4 pages.
- Gloss, F., "The 'Zurich Ring,' a Prototype Token-Ring Local Area Network," *International Business Machines Corporation 1986*, Document No. GA27-3732-0, Part No. 61X3816, 3 pages.
- Coburn, R. L., and Stammely, T. E., "The Single-Chip Transceiver," *International Business Machines Corporation 1986*, Document No. GA27-3732-0, Part No. 61X3816, 3 pages.
- Cook, A., and Stern, J., "Optical Fiber Access—Perspectives Toward the 21st Century," *IEEE Communications Magazine*, (Feb. 1994), pp. 78-86.
- "Cornerstone Voice—Economical Delivery of Telephony Services in the Hybrid Fiber/Coax Network," *Cornerstone*, Issue 2, (Aug. 1996), 22 pages.
- Dale, O. B., et. al., "A Highly Distributed Mechanized Loop Testing System," *IEEE Transactions on Communications*, vol. Com-30, No. 9, (Sep. 1982), pp. 2038-2045.
- David Information Manager, *David 3270 Coax Eliminator*, (Jan. 1986), 4 pages.
- David Information Manager, *David—Adapters*, (Feb. 1985), 2 pages.
- David Information Manager, *David Asynchronous Communications*, (May 1986), 2 pages.
- David Information Manager, *David—Link*, (Feb. 1985), 1 page.
- David Information Manager, *David Local Area Networking*, (May 1986), 4 pages.
- David Information Manager, *David—Set*, (Feb. 1985), 2 pages.
- David Information Manager, *The David Information Manager Overview*, (Feb. 1985), 3 pages.
- David Information Manager, *The David—Manager*, (Feb. 1985), 2 pages.
- David Information Manager, *The David Solution*, (Feb. 1985), 4 pages.
- David Systems, *David Co-Net—Command Reference*, (Dec. 1988), 342 pages.
- David Systems, *David Co-Net—Information Manager Network Configuration Manual*, (Dec. 1988), 98 pages.
- David Systems, *David Co-Net—Installation Manual*, (Dec. 1988), 228 pages.
- David Systems, *David Co-Net—Maintenance Manual*, (Dec. 1990), 309 pages.
- David Systems, *David Co-Net System Administrator's Guide*, (1991), 187 pages.
- David Systems, *David Co-Net—Technical Reference Manual*, (Dec. 1988), 326 pages.
- David Systems, *David Co-Net, Voice and Data Configuration Manual*, (Oct. 1990), 233 pages.
- David Systems, *David ExpressNet LAN—Twisted-Pair Installation and Operation Manual (Model 6206 Hub and 6209 MAU)*, (Jan. 1990), 160 pages.
- David Systems, *David Information Manager—Administration Manual*, (Apr. 7, 1988), 360 pages.
- David Systems, *David Information Manager—Feature Reference*, (date unknown), 44 pages.
- David Systems, *David Information Manager—System Description Manual*, (Mar. 1987), 114 pages.
- David Systems, *David Information Manager—Technical Overview*, (date unknown), 74 pages.
- David Systems, *David Stand Alone Information Manager—System Description*, (Apr. 21, 1987), 113 pages.
- David Systems, *David Stand Alone Product Specification, Release 8*, (Aug. 19, 1988), 95 pages.
- Dixon, R. C., "Token-Ring Support of Synchronous Data," *International Business Machines Corporation 1986*, Document No. GA27-3732-0, Part No. 61X3816, 3 pages.
- Don Carlos, B. J., and Winkler, J. L., "Distributed Management for a Token-Ring Local Area Network," *International Business Machines Corporation 1986*, Document No. GA27-3732-0, Part No. 61X3816, 2 pages.
- Donnan, R. and Pitt, D., "Local Area Network Standards," *International Business Machines Corporation 1986*, Document No. GA27-3732-0, Part No. 61X3816, 3 pages.
- Dow Jones & Co., Inc.—*Dow Jones News—Northern Telecom*, (Nov. 14, 1994), 1 page.
- Droms, R., Bucknell University, "Dynamic Host Configuration Protocol," (Oct. 1993), 40 pages.
- Duffie, C. A. P., "A Cable Network Planning and Maintenance System," *International Business Machines Corporation 1986*, Document No. GA27-3732-0, Part No. 61X3816, 2 pages.
- Efficient Networks—*Business Class DSL Routers—SpeedStream 5800 series*, (Jul. 2000), 2 pages.
- Feldman, R., "Spreckels Sugar Gets Sweet on David Systems LAN," *Data Communications*, (Mar. 24, 1986), 1 page.
- FlowPoint Cabletron Systems, *FlowPoint FP2200 SDSL Router, Firmware version 3.0.8, P/N: 222-00513-04*, (Jun. 21, 1999), 6 pages.
- FlowPoint Cabletron Systems, *FlowPoint Router 2200-12, SDSL Router—Quick Start Guide, P/N 222-00627-01*, (Mar. 1999), 45 pages.

(56)

References Cited

OTHER PUBLICATIONS

- Fodell, D., and McDaniel, G., "Documenting the IBM Token-Ring Network," International Business Machines Corporation 1986, Document No. GA27-3732-0, Part No. 61X3816, 3 pages.
- Freedman, D. R., "Transmission Subsystem," International Business Machines Corporation 1986, Document No. GA27-3732-0, Part No. 61X3816, 2 pages.
- Gamewell-FCI, Three-Fold Fire Alarm Boxes and Transmitters, (2009), 4 pages.
- Goldberg, E., "PBX, local-area net hybrid meets firm's voice/data needs," Computerworld, (Feb. 17, 1986), 1 page.
- Evans, G., "The CEBus Standard User's Guide," 1st ed., (May 1996), 317 pages.
- Gurusami, A., Cox, J., and Chapman, M., "Multimedia Delivery Device for Fiber/Coaxial Hybrid Networks," Reprinted from NCTA Technical Sessions, (1994), 6 pages.
- Hall, J. L. and Hosne-Sanaye, S., "Personal Computer Token-Ring Adapter Attachment," International Business Machines Corporation 1986, Document No. GA27-3732-0, Part No. 61X3816, 2 pages.
- High, L., "ADC Provides Homeworx Telephony System to Nanjing CATV," Business Wire, (Nov. 6, 1997), 2 pages.
- Hobgood, B., "The Characteristic Impedance of IBM's Balanced, Twisted-Pair Cable," International Business Machines Corporation 1986, Document No. GA27-3732-0, Part No. 61X3816, 2 pages.
- Hobgood, B., and Overby, A.W., "Measuring Crosstalk in the IBM Cabling System," International Business Machines Corporation 1986, Document No. GA27-3732-0, Part No. 61X3816, 3 pages.
- Hong, J., "Synchronization of the Token-Ring," International Business Machines Corporation 1986, Document No. GA27-3732-0, Part No. 61X3816, 2 pages.
- IEEE 802.9 Draft Standard Integrated Services (IS) LAN Interface at the MAC and PHY Layers—Project 802—Local & Metropolitan Area Networks, (Nov. 8, 1992), Part 1, 250 pages.
- IEEE 802.9 Draft Standard Integrated Services (IS) LAN Interface at the MAC and PHY Layers—Project 802—Local & Metropolitan Area Networks, (Nov. 8, 1992), Part 2, 252 pages.
- IEEE 802.9a-1995 (Supplement to IEEE Std 802.9-1994)—"IEEE Standards for Local and Metropolitan Area Networks: Supplement to Integrated Services (IS) LAN Interface at the Medium Access Control (MAC) and Physical (PHY) Layers: Specification of ISLAN16-T," (Feb. 16, 1996), Part 1, 340 pages.
- IEEE 802.9a-1995 (Supplement to IEEE Std 802.9-1994)—"IEEE Standards for Local and Metropolitan Area Networks: Supplement to Integrated Services (IS) LAN Interface at the Medium Access Control (MAC) and Physical (PHY) Layers: Specification of ISLAN16-T," (Feb. 16, 1996), Part 2, 348 pages.
- IEEE, P802.9f, D4—Draft Standard for Local and Metropolitan Area Networks—Supplement to Integrated Services (IS) LAN Interface at the Medium Access Control (MAC) and Physical (PHY) Layers, (Nov. 7, 1996), 22 pages.
- IEEE Std. 802.3, 2000 Edition—"Part 3: Carrier Sense Multiple Access with Collision Detection (CSMA/CD) Access Method and Physical Layer Specifications," Adopted by the ISO/IEC and redesignated as ISO/IEC 8802-3:2000(E), 217 pages.
- ITU (International Telecommunication Union)—CCITT (The International Telegraph and Telephone Consultative Committee)—Series Q: Switching and Signalling Digital Subscriber Signalling System No. 1 (DSS 1), Network Layer, User-Network Management—Network Layer—ISDN User-Network Interface Layer 3—Specification for Basic Call Control, (Nov. 1988), 352 pages.
- ITU (International Telecommunication Union)—CCITT (The International Telegraph and Telephone Consultative Committee)—Series Q: Digital Subscriber Signalling System No. 1 (DSS 1), Data Link Layer—ISDN User-Network Interface Data Link Layer—General Aspects, (Nov. 1988), 20 pages.
- ITU (International Telecommunication Union)—CCITT (The International Telegraph and Telephone Consultative Committee), Series Q: Digital Subscriber Signalling System No. 1 (DSS 1), Data Link Layer—ISDN User-Network Interface—Data Link Layer Specification, (Nov. 1988), 118 pages.
- ITU-T Recommendation I.430—Integrated Services Digital Network (ISDN)—ISDN User-Network Interfaces—Basic User-Network Interface—Layer 1 Specification, (Mar. 1993), 106 pages.
- ITU-T Recommendation I.431—Integrated Services Digital Network (ISDN)—ISDN User-Network Interfaces—Primary Rate User-Network Interface—Layer 1 Specification, (Mar. 1993), 44 pages.
- Incite System Guide—User's Guide for installing and configuring the Incite Multimedia Network, (Jun. 1997), 655 pages.
- Industry Spotlight, Chipcom Connections, vol. 1, No. 3, (Oct. 1988), pp. 3-4.
- Kapil, V. K., "Performance Analysis of the IBM Token-Ring Network," International Business Machines Corporation 1986, Document No. GA27-3732-0, Part No. 61X3816, 3 pages.
- Karounos, C., et al., "Digital Repeaters for Ring Networks," International Business Machines Corporation 1986, Document No. GA27-3732-0, Part No. 61X3816, 3 pages.
- Kates, D. H., "Gateways and Bridges for Local Area Networks," International Business Machines Corporation 1986, Document No. GA27-3732-0, Part No. 61X3816, 2 pages.
- Labus, C., "Reliability, Availability and Serviceability," International Business Machines Corporation 1986, Document No. GA27-3732-0, Part No. 61X3816, 3 pages.
- Leech, R. L., "Communication Adapter Microcode Development," International Business Machines Corporation 1986, Document No. GA27-3732-0, Part No. 61X3816, 2 pages.
- Long-Distance Interconnection for Ethernet Subnetworks using Map Broadband and Backbone, Chipcom Connections, vol. 1, No. 3, (Oct. 1988), p. 1.
- Love, R. D., "Media-Transmission Characteristics for a Local Area Network," International Business Machines Corporation 1986, Document No. GA27-3732-0, Part No. 61X3816, 2 pages.
- Love, R. D. and Toher, T., "Theory for Configuration Rules," International Business Machines Corporation 1986, Document No. GA27-3732-0, Part No. 61X3816, 3 pages.
- Lucent Technologies, TN556 Basic Rate Line Functional Design Specification, Issue 1, (Jan. 23, 1987), 38 pages.
- Lucent Technologies, TN556 ISDN Line Functional Requirements, Issue 3.0, (Jul. 6, 1992), 49 pages.
- M2 Communications Ltd.; M2 Presswire—"Nortel—Chile's VTR awards Nortel contract for Latin America's first Hybrid Fiber Coax telephone network," (Dec. 4, 1996), 2 pages.
- M2 Communications Ltd.; M2 Presswire—"Nortel—Nortel delivers experimental cable telephony system to TV Chigasaki," (Aug. 28, 1996), 1 page.
- M2 Communications Ltd.; M2 Presswire—West End Networks—West End appoints NODE PTA as principal distributor in the Czech Rep & Slovakia, (Oct. 18, 1996), 1 page.
- M2 Communications Ltd.; M2 Presswire—West End shows Broadband Access Platform for first time, (Nov. 22, 1994), 1 page.
- Maxey, H. D., "Estimating Token-Ring Length when Analyzing Performance," International Business Machines Corporation 1986, Document No. GA27-3732-0, Part No. 61X3816, 2 pages.
- Merk, C. A., "Convergence: Telephony and Video Distribution Network Migration Projections," Reprinted from the SCTE Technical Sessions, (1994), 10 pages.
- Munn, R. D., "Optical Fiber Connector Selection," International Business Machines Corporation 1986, Document No. GA27-3732-0, Part No. 61X3816, 2 pages.
- National Semiconductor, Fiber Distributed Data Interface (FDDI) Databook, (1991 edition), Part 1, 300 pages.
- National Semiconductor, Fiber Distributed Data Interface (FDDI) Databook, (1991 edition), Part 2, 262 pages.
- Negus, K. J., et al., "HomeRF and SWAP: Wireless Networking for the Connected Home," Mobile Computing and Communications Review, vol. 2, No. 4, (Oct. 1998), pp. 28-37.
- Nortel Product Portfolio—Cornerstone Voice—Economic delivery of narrowband services—any mix of standard and custom calling services—in the hybrid fiber/coax network, (date unknown), 2 pages.
- North America's Home & Building Automation Association, CABA Information Series, "The Residential Gateway Report & TIA/EIA Residential Gateway, CABA: IS-98-5," (Dec. 1995), 70 pages.
- Northern Telecom—Background Information—Cornerstone Multimedia, (date unknown), 3 pages.

(56)

References Cited

OTHER PUBLICATIONS

- Northern Telecom—Background Information—Total Network Solutions and Cornerstone, (date unknown), 2 pages.
- Northern Telecom—Cornerstone Data—High-Speed Connections for Telecommuting, Small Business, and On-Line Services, (Nov. 1994), 2 pages.
- Northern Telecom—Cornerstone PCS—Cost-Effective, Rapid PCS Market Entry for Cable Providers, (Nov. 1994), 2 pages.
- Northern Telecom—Cornerstone Voice—Low-Cost, Feature-Rich Services for Home or Business, (Nov. 1994), 2 pages.
- Northern Telecom—News Release—New Total Network Solutions Program Supports Emerging Service Providers, (Nov. 8, 1994), 3 pages.
- Northern Telecom—News Release—Northern Telecom Announces New Hybrid Fiber / Coax Products, (Nov. 14, 1994), 3 pages.
- Northern Telecom—News Release—Northern Telecom Demonstrates End-to-End Telephony Solution, (Nov. 29, 1994), 2 pages.
- Northern Telecom—PCS Over Coax: Cornerstone, SmartCard, and Short Message Service, (date unknown), 2 pages.
- O'Brien, J. J., "Electric Circuits—The Guardians of Life and Property—A History and Discussion of the Fire Alarm System of San Francisco," The Virtual Museum of San Francisco, <http://www.sfmuseum.net/hist10/cfaspaper.html>, (Apr. 2, 1951), 6 pages.
- PR Newswire Association, Inc.—"Newt Gingrich Tests Cable Telephony Product," (Sep. 12, 1995), 2 pages.
- PR Newswire Association, Inc.; PR Newswire—"Antec and Northern Telecom (Nortel) Seal Joint Venture Agreements," (Nov. 6, 1995), 2 pages.
- PairGain Technologies—Quick Installation Guide for PairGain Technologies HiGain Remote Enclosure Model HRE-421 Issue 1, Section 100-421-100, Revision 05, (Aug. 15, 1995), 6 pages.
- Persson, P. and Selander, L., "An Internet Camera Server for USB Cameras," Master's Thesis, Lund Institute of Technology, Lund, Sweden, (Aug. 29, 1997), 141 pages.
- Philips—Broadband Communications Gateway, (Jun. 13, 1994), 1 page.
- Philips—Broadband Communications Gateway—Applications, (Jun. 13, 1994), 1 page.
- Philips—Broadband Communications Gateway—Headend / Central Office Equipment, (Jun. 13, 1994), 1 page.
- Philips—Broadband Communications Gateway—Network Interface Unit (NIU)—Type: Premise Threshold / Indoor for implementation of CCITT standards, (Jun. 13, 1994), 2 pages.
- Philips—Broadband Communications Gateway—Network Interface Unit (NIU)—Type: Single Premise Unit for Strand, Side of Premise, Pedestal Implementations, (Jun. 13, 1994), 2 pages.
- Philips—Broadband Communications Gateway Specifications: Headend / Central Office Equipment, (Jun. 13, 1994), 1 page.
- Pitt, D., "Standards for the Token Ring," IEEE Network Magazine, vol. 1, No. 1, (Jan. 1987), pp. 19-22.
- Responsive Database Services, Inc.—Bohemian trial for hybrid fibre-coax, (Dec. 1997), 1 page.
- Responsive Database Services, Inc.—Cable telephony network for Poland, (Nov. 14, 1997), 1 page.
- Responsive Database Services, Inc.—Korea: Telephony on cable, (Mar. 1997), 1 page.
- Responsive Database Services, Inc.—Korean first underway, (May 1997), 1 page.
- Responsive Database Services, Inc.—New Distributor, (Dec. 4, 1995), 1 page.
- Responsive Database Services, Inc.—Texscan Adds Net Management Partner, (May 22, 1995), 1 page.
- Responsive Database Services, Inc.—The Telecom Industry in Canada, (Nov. 1996), 7 pages.
- Responsive Database Services, Inc.—Voz y datos a traves de TV por cable, (Feb. 29, 1996), 1 page.
- Responsive Database Services, Inc.—West End Bridge-Building, (Jul. 1996), 1 page.
- Responsive Database Services, Inc.—West End Networks/ComTech to show Broadband Access Platform, (Mar. 1996), 1 page.
- Responsive Database Services, Inc.—West End Networks planning Nasdaq IPO next year, (May 7, 1997), 2 pages.
- Responsive Database Services, Inc.—West End Signs Taiwanese Firms, (Sep. 30, 1996), 1 page.
- Responsive Database Services, Inc.—West End Ups Cable Capacity, (Oct. 20, 1994), 1 page.
- Responsive Database Services, Inc.; Informa UK Ltd.; Cable Business International—Superhighway sliproads now open, (Oct. 1996), 2 pages.
- Ross, F. E., "Rings Are 'Round for Good," IEEE Network Magazine, vol. 1, No. 1, (Jan. 1987), pp. 31-38.
- Ross, T., "Optical Fiber Cable Design for Local Communication Applications," International Business Machines Corporation 1986, Document No. GA27-3732-0, Part No. 61X3816, 2 pages.
- Saltzer, J. H. and Pogran, K. T., "A Star-Shaped Ring Network With High Maintainability," Proceedings of the LACN Symposium, (May 1979), pp. 179-190.
- Sauer, L. and Friedrich, A., "Simulation of Eye Patterns in Designing a Local Area Network," International Business Machines Corporation 1986, Document No. GA27-3732-0, Part No. 61X3816, 3 pages.
- Schoechle, T., "HomeGate: Current Issues on Broadband Interworking and the Residential Gateway," ISO-IEC JTC1/SC25/WG1 N 710, (Jun. 16, 1997), 109 pages.
- See, M., "Specifying Optical Fibers for a Local Area Network," International Business Machines Corporation 1986, Document No. GA27-3732-0, Part No. 61X3816, 2 pages.
- Snider, D. M., "The Communication Adapter," International Business Machines Corporation 1986, Document No. GA27-3732-0, Part No. 61X3816, 2 pages.
- Stammely, T., "Fan-Out Connectors for Local Area Networks," International Business Machines Corporation 1986, Document No. GA27-3732-0, Part No. 61X3816, 3 pages.
- Stammely, T. E., "Physical Connection to a Token Ring: Multistation Access Units," International Business Machines Corporation 1986, Document No. GA27-3732-0, Part No. 61X3816, 2 pages.
- Staton, J. B., "Systems Network Architecture on the IBM Token-Ring Network," International Business Machines Corporation 1986, Document No. GA27-3732-0, Part No. 61X3816, 2 pages.
- Steen, R. F., "Introducing the IBM Token-Ring Network," International Business Machines Corporation, 1986, Document No. GA27-3732-0, Part No. 61X3816, 8 pages.
- Stilwell, G. R., and Noel, F. E., "System Growth Via Optical Fiber Transmission," International Business Machines Corporation 1986, Document No. GA27-3732-0, Part No. 61X3816, 2 pages.
- Strauss, P. R., "The Hills Are Alive: Seedling Firms Keep Replacing Deadwood," Data Communications, (Mar. 1985), 7 pages.
- Strole, N. C., "Token-Ring Local Area Networks: An Overview," International Business Machines Corporation 1986, Document No. GA27-3732-0, Part No. 61X3816, 6 pages.
- Suffern, E., "A Common Wiring System," International Business Machines Corporation 1986, Document No. GA27-3732-0, Part No. 61X3816, 3 pages.
- Sultanem, F., "Using Appliance Signatures for Monitoring Residential Loads at Meter Panel Level," IEEE Transactions on Power Delivery, vol. 6, No. 4, (Oct. 1991), pp. 1380-1385.
- Sy, K. B. and Winkler, J. L., "'Priority-with-Fairness' in a Token-Ring Local Area Network," International Business Machines Corporation 1986, Document No. GA27-3732-0, Part No. 61X3816, 2 pages.
- SynOptics Communications, Inc., Product Announcement—Advanced Network Management for Ethernet and Token Ring, (Mar. 4, 1991), 15 pages.
- UMI, Inc.; ABI/Inform; Bell Northern Research Ltd.—"Broadband solutions for cable companies," (Oct. 1995), 3 pages.
- UMI, Inc.; ABI/Inform; Bell Northern Research Ltd.—"World Line Card helps deliver telephony services over coax," (Oct. 1995), 2 pages.
- U.S. Robotics, Courier I-Modem—Command Reference, (1996), 219 pages.
- U.S. Robotics, Courier Internal I-Modem—Getting Started, (1996), 64 pages.
- "Universal Serial Bus Device Class Definition for MIDI Devices," Release 1.0, USB Implementers Forum, (Nov. 1, 1999), 43 pages.

(56)

References Cited

OTHER PUBLICATIONS

"Universal Serial Bus Device Class Definitions for Communication Devices," Version 1.1, USB Implementers Forum, (Jan. 19, 1999), 121 pages.

"Universal Serial Bus PC Legacy Compatibility Specification," 0.9 Draft Revision, USB Implementers Forum, (May 30, 1996), 19 pages.

VERLINK, Connect1 DSU (Data Service Unit), 880-500986-001-E, (1989), 88 pages.

Vodicka, R. E., "Advantages of the IBM Token-Ring Network," International Business Machines Corporation 1986, Document No. GA27-3732-0, Part No. 61X3816, 3 pages.

Wakerly, J. F., and Sammartino, F., "Attaching RS-232 and LAN Capabilities to an Existing Voice-Only Switching Network," date unknown, 46 pages.

Walker, J. Q., "Dynamic Connectivity," International Business Machines Corporation 1986, Document No. GA27-3732-0, Part No. 61X3816, 2 pages.

Waller, R. and Wilson, K. T., "Ring Poll: A Message Protocol to Aid Error Isolation," International Business Machines Corporation 1986, Document No. GA27-3732-0, Part No. 61X3816, 3 pages.

West End—WestBound 9600 Broadband Access Platform—Take the Reliable Route, (1994), 5 pages.

West End—WestBound 9645 Broadband Manager, (1994), 2 pages.
Westell—General Purpose NIU—3125 Series T1 Network Interface Unit, (2000), 2 pages.

Wimer, W., Carnegie Mellon University, "Clarifications and Extensions for the Bootstrap Protocol," (Oct. 1993), 23 pages.

Wilson, K. T., "Ring Error Detection and Recovery," International Business Machines Corporation 1986, Document No. GA27-3732-0, Part No. 61X3816, 3 pages.

Wireless, Inc., 2.4 GHz ACCESS MicroLink Operations Manual, (Nov. 1998), 106 pages.

Wireless, Inc.—ACCESS Link Microwave Radio Terminal, (date unknown), 3 pages.

Wireless, Inc.—ACCESS Micro Link System—(Draft) Hardware Design Description, (Aug. 1998), 36 pages.

Wireless, Inc.—ACCESS Series, (date unknown), 2 pages.

David Information Manager, David—Set™, (Feb. 1985), 2 pages.

EtherLink III Parallel Tasking PCI Bus Master Network Adapters User Guide, 3Com Corporation, Apr. 1995, 76 pages.

IEEE Std. 802.3, 1993 edition—"Part 3: Carrier Sense Multiple Access with Collision Detection (CSMA/CD) Access Method and Physical Layer Specifications," 292 pages.

IEEE Std. 802.3, 1998 edition—"Part 3: Carrier Sense Multiple Access with Collision Detection (CSMA/CD) Access Method and Physical Layer Specifications," 1262 pages.

* cited by examiner

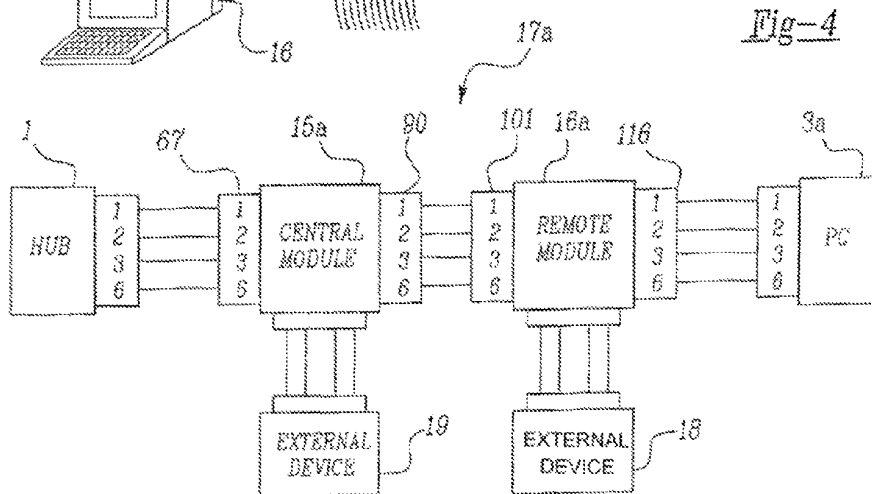
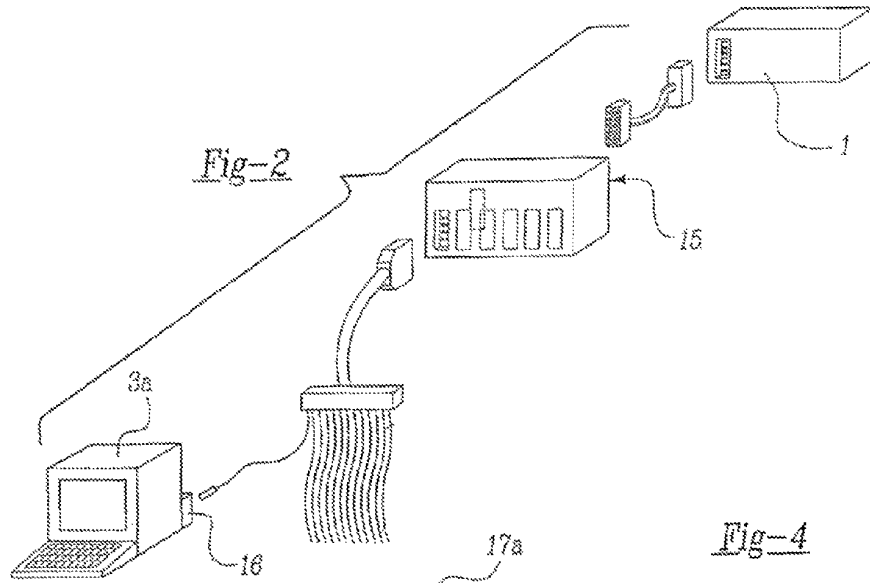
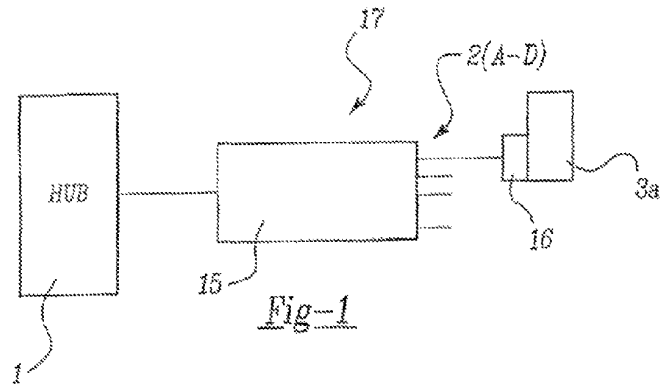

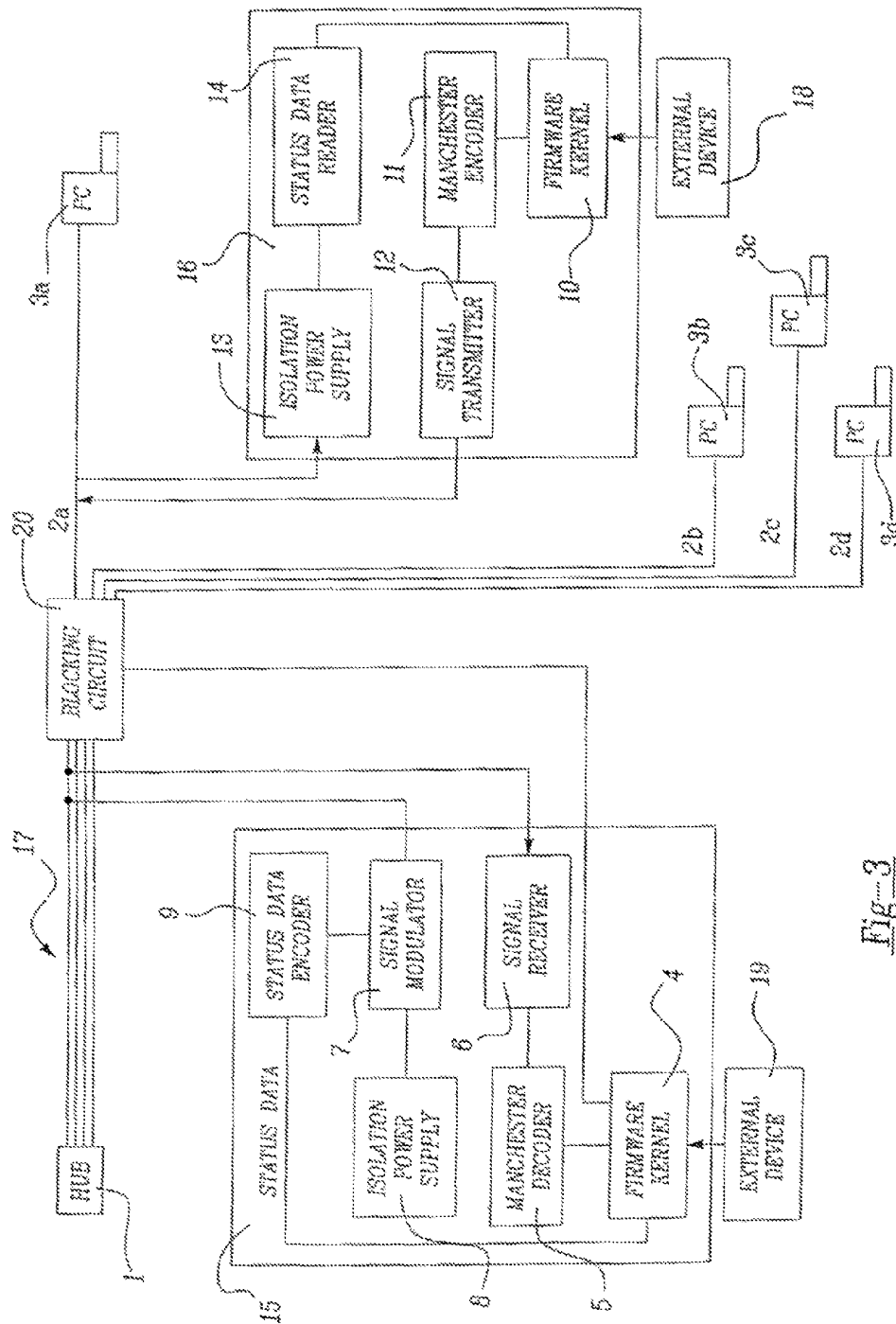

Fig. 3

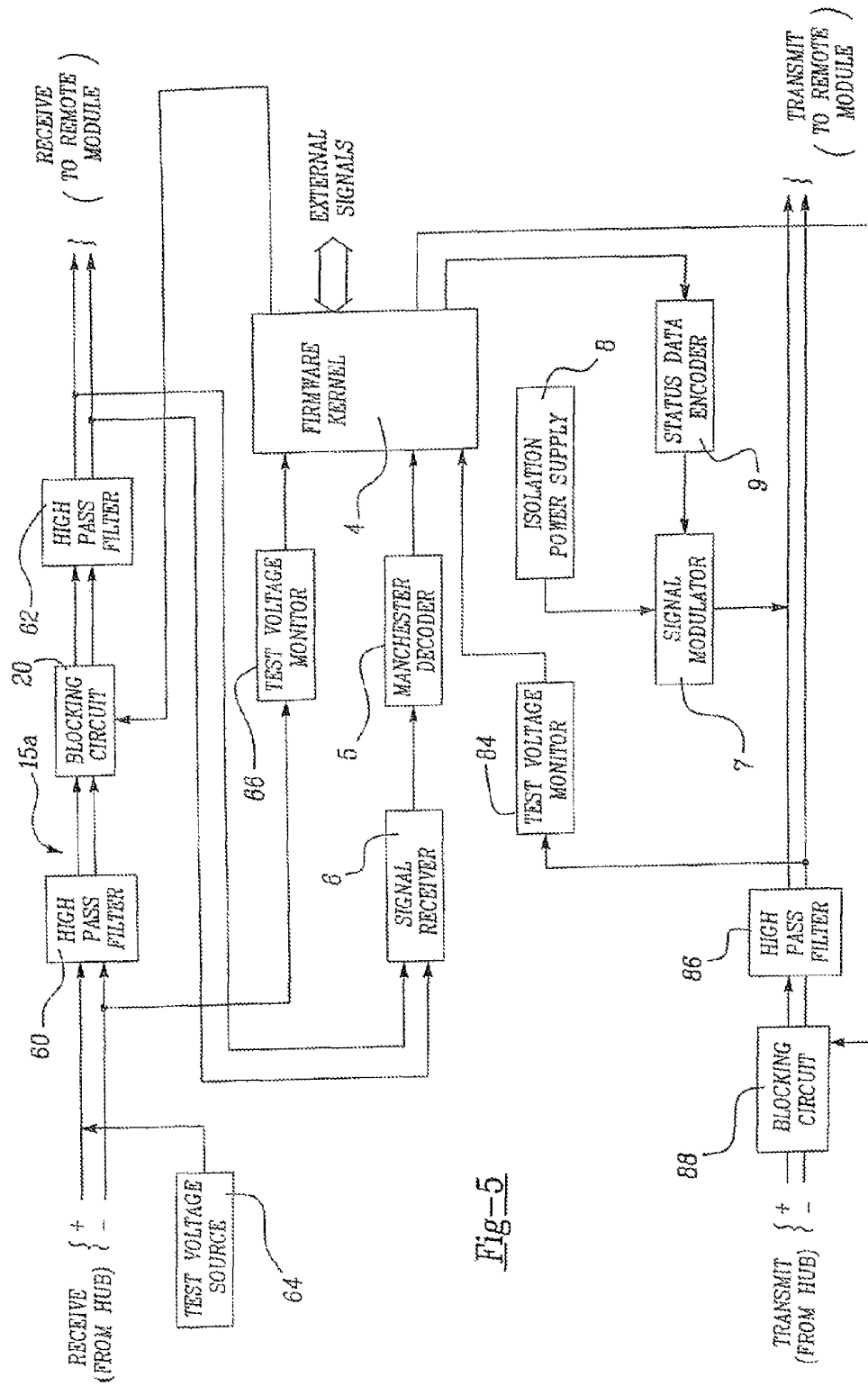

Fig-5

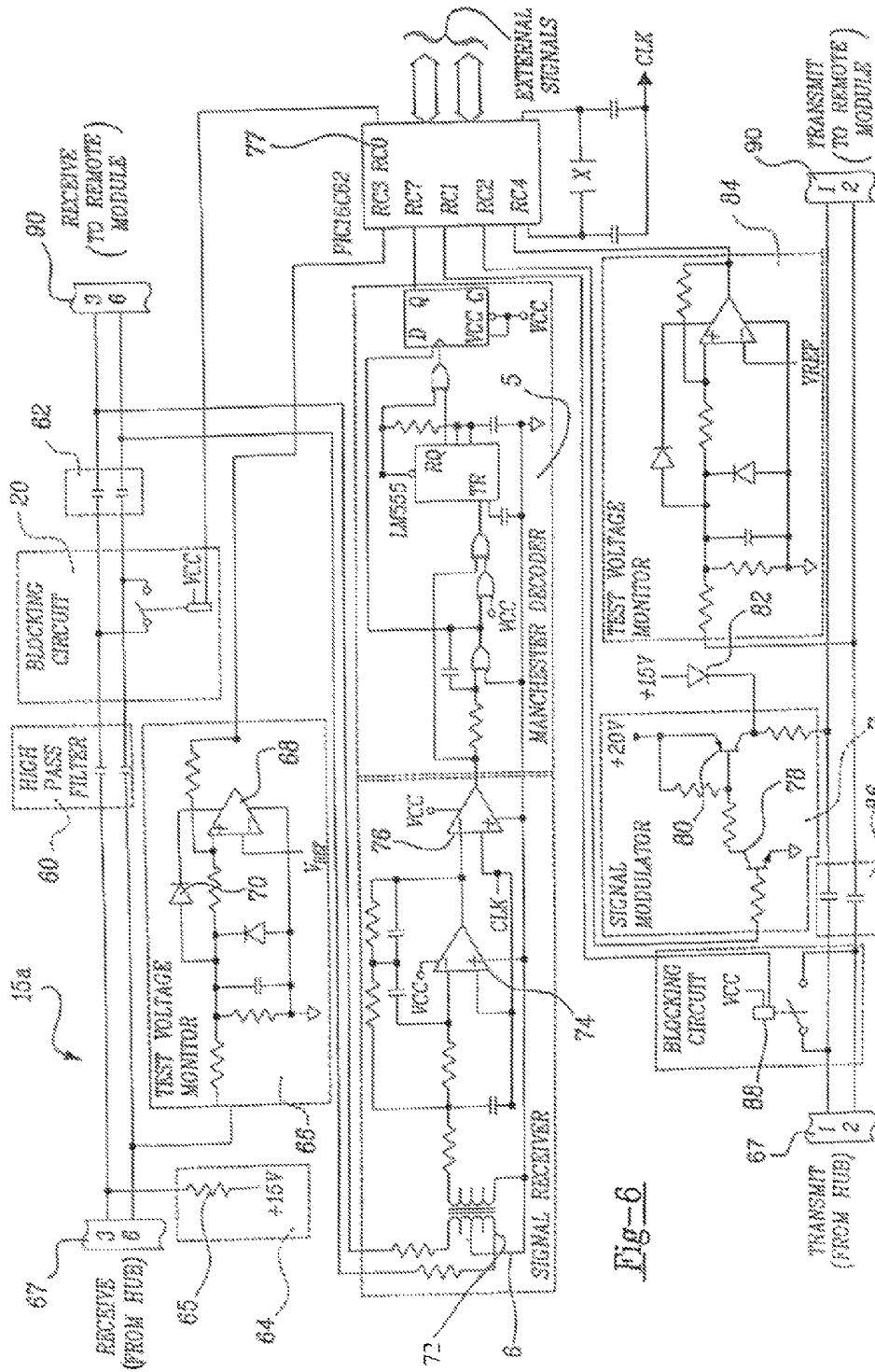
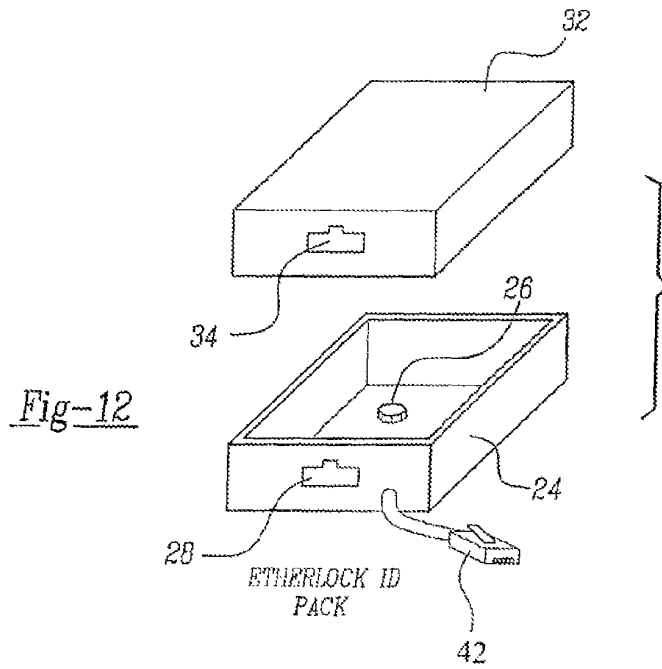
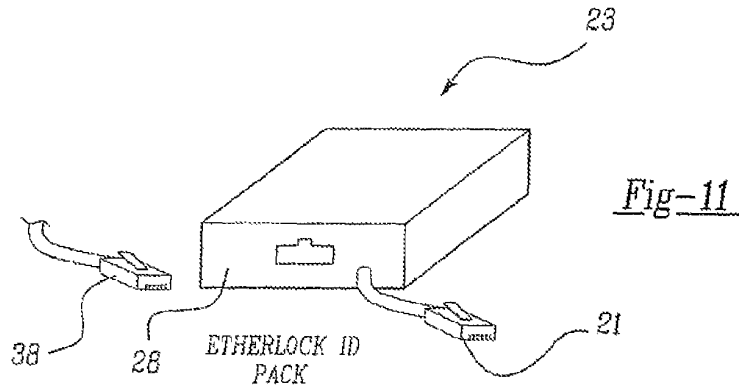
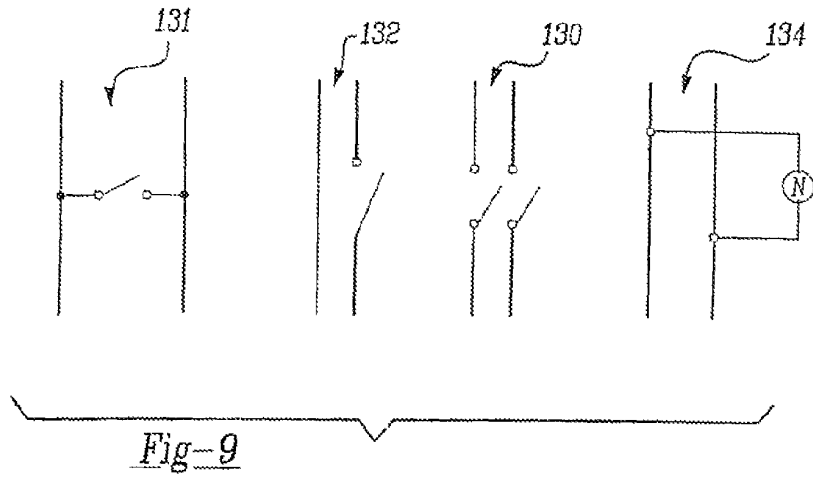

Fig-6



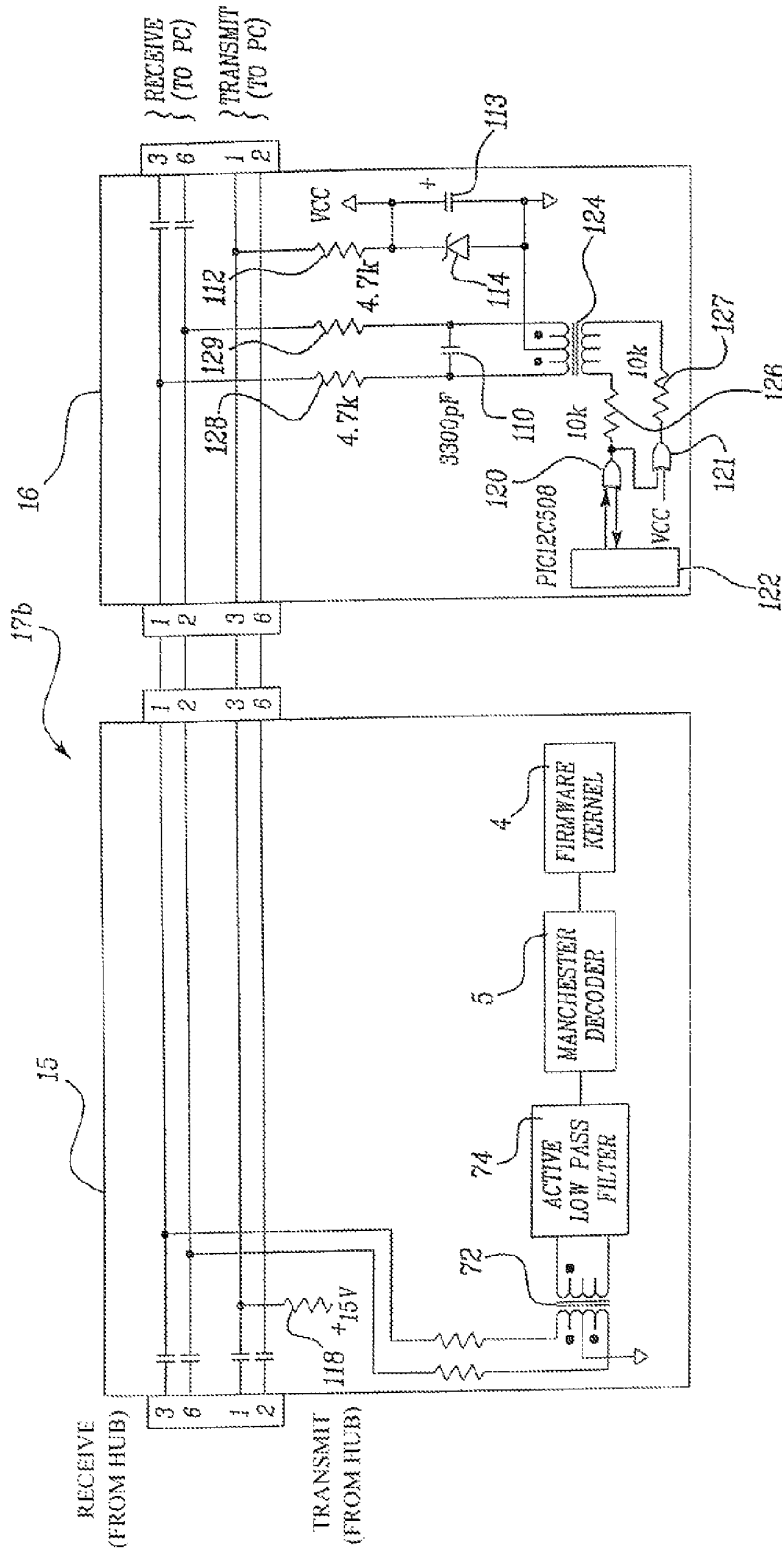
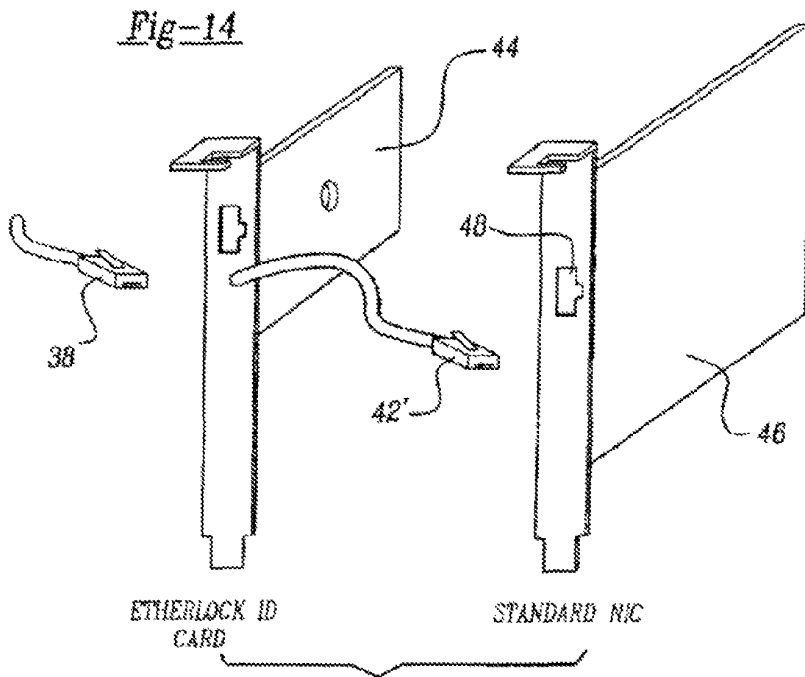
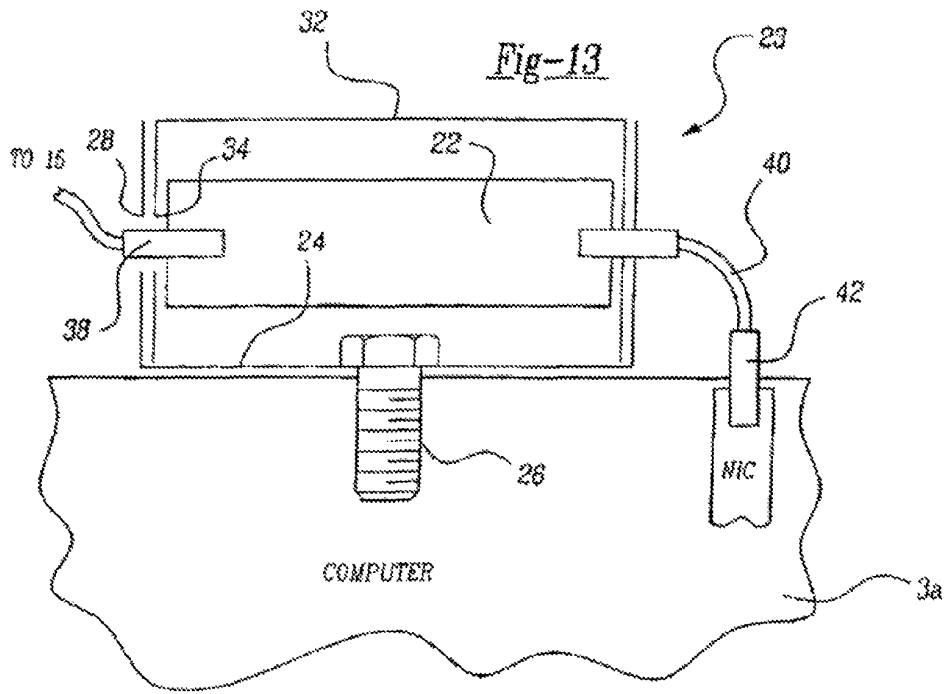

Fig-10



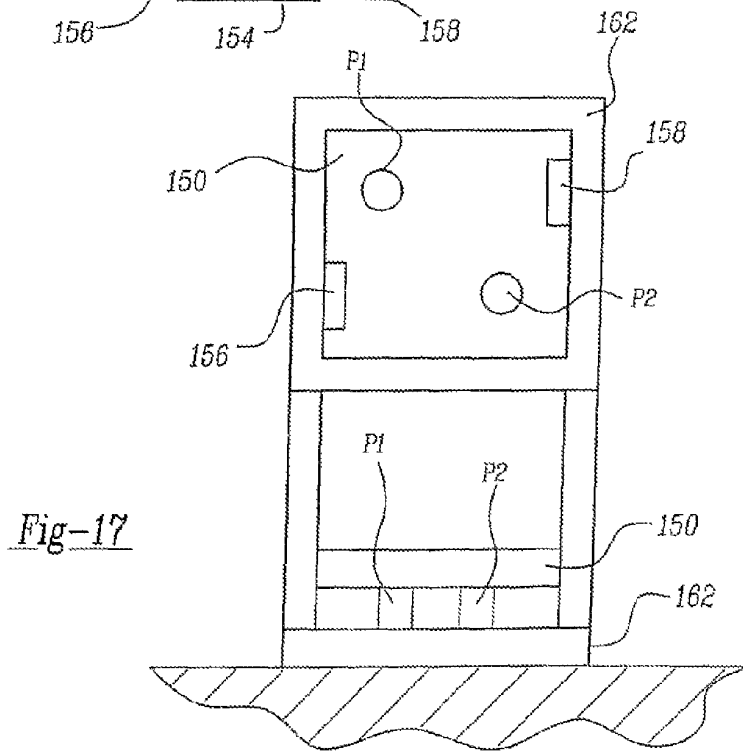
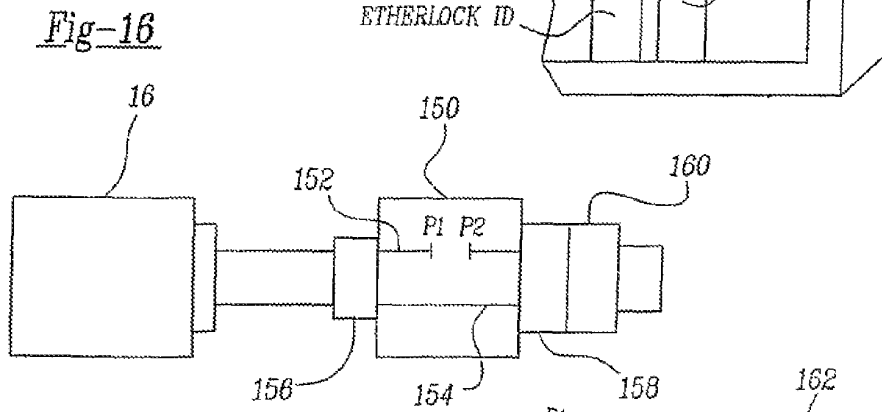
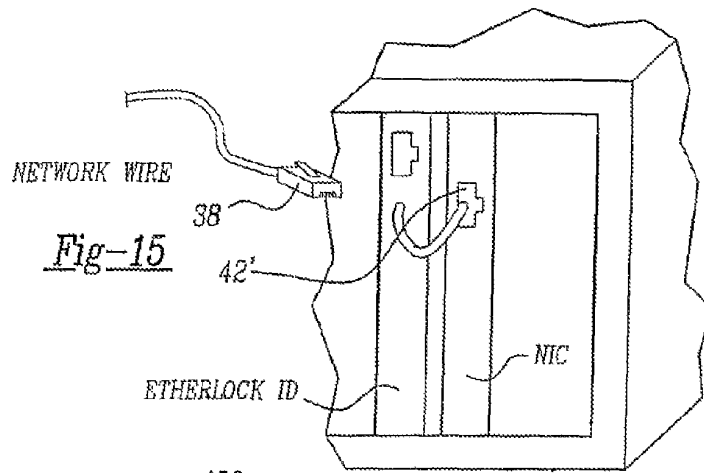
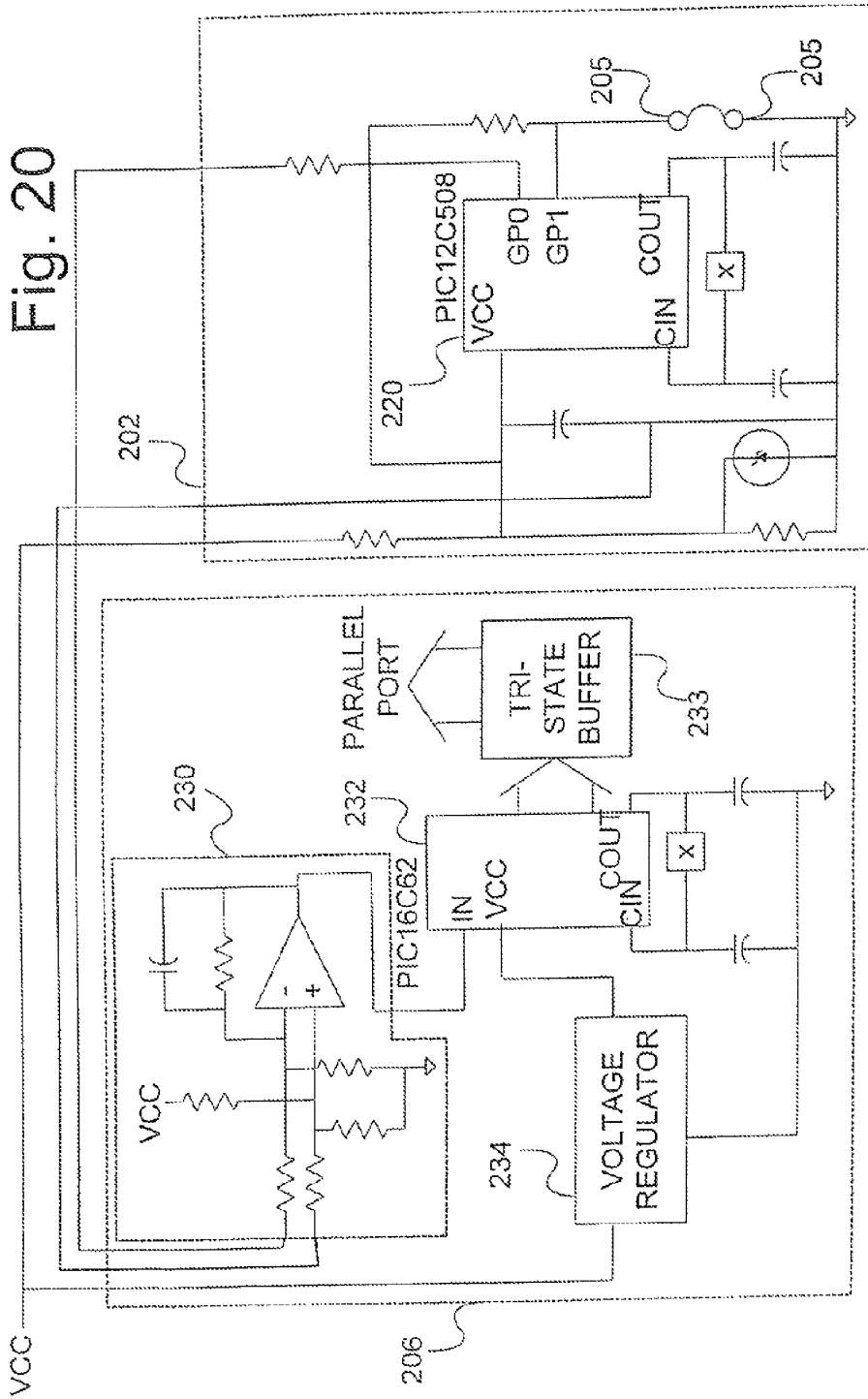
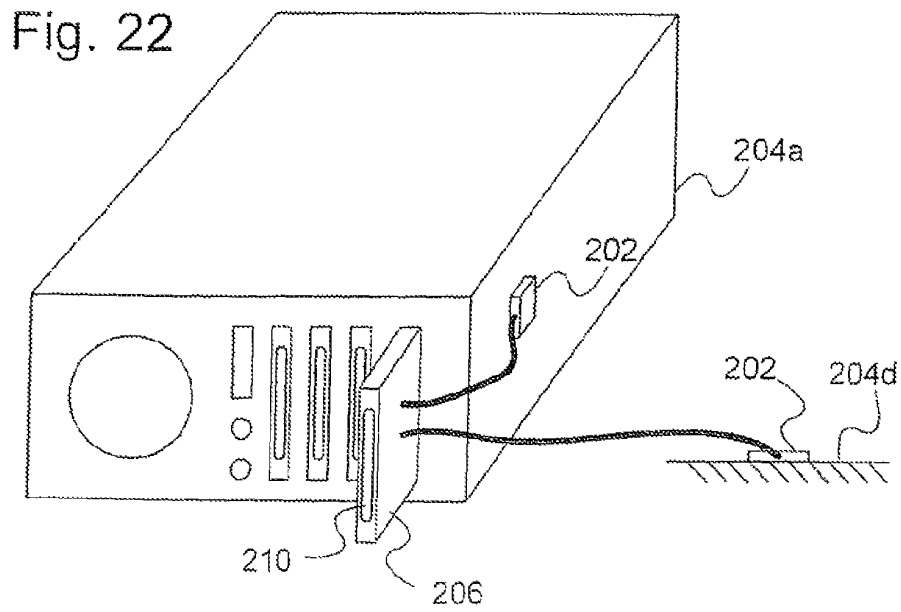
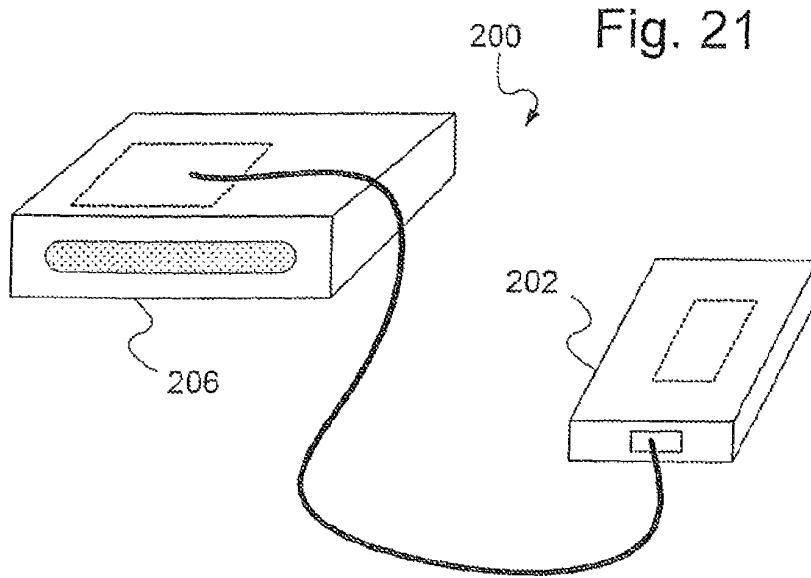

Fig. 20





PIECE OF ETHERNET TERMINAL EQUIPMENT

CROSS REFERENCE TO RELATED APPLICATIONS

This application is a continuation application of U.S. patent application Ser. No. 12/239,001 filed Sep. 26, 2008, now U.S. Pat. No. 8,155,012 issued Apr. 10, 2012, which is a continuation application of U.S. patent application Ser. No. 10/668,708 filed Sep. 23, 2003, now U.S. Pat. No. 7,457,250 issued Nov. 25, 2008, which is a continuation of U.S. patent application Ser. No. 09/370,430 filed Aug. 9, 1999, now U.S. Pat. No. 6,650,622 issued Nov. 18, 2003, which is a continuation-in-part under 35 U.S.C. §111 and §120 of International Application PCT/US99/07846, filed Apr. 8, 1999, designating, inter alia, the United States, and which claims the benefit of U.S. Provisional Patent Application No. 60/081,279 filed Apr. 10, 1998. The entire content of each of the above mentioned applications and patents are incorporated herein by reference.

BACKGROUND OF THE INVENTION

1. Technical Field

This invention relates generally to computer networks and, more particularly, to a network management and security system for managing, tracking, and identifying remotely located electronic equipment on a network.

2. Discussion

Over the last several years, one of the largest problems in managing the computerized office environment has been identified as controlling the Total Cost of Ownership, or TCO, of the office computer. Controlling TCO includes not only the cost of the asset but also all costs associated with that asset, such as support costs, software costs, and costs due to loss or theft, including hardware, software, and most importantly, information.

An aspect of the support costs of TCO is asset movement. Today, many employees have more than one computer. When that employee is moved to another location, the assets must be moved as well. A typical organization can have as much as 40% of its employees move from one location to another over the course of a year. When these movements occur daily, tracking each asset over time is nearly impossible. There is also the unauthorized movement of assets, such as moving an asset from an employee's office to his or her associated lab area. In addition to these physical movements, the asset may also be changed over time through hardware and software modifications. Even if an asset is successfully tracked over a period of time, the asset may not be the same at the end of the period. Due to this constant asset relocation and reorganization, an organization may not always know where all of its assets are located. In fact, it is very likely that a company may not even know how many assets they own or if those assets are still in their possession. Additionally, an organization that desires to send a message to all of the assets within a particular physical area is limited to relying on databases that correlate the network identification of an asset to where that asset should be located, not where the asset actually is located. Previous attempts to provide asset tracking and management have relied on software solutions that have proven to be fundamentally flawed. Asset tracking and management software is limited in a number of important areas. It is generally incapable of detecting the electrical connection status of equipment, it cannot detect the physical location of equip-

ment, the identifying name of equipment is not permanent, and the monitored assets must be powered-up.

Therefore, a method for permanently identifying an asset by attaching an external or internal device to the asset and communicating with that device using existing network wiring or cabling is desirable. Also, it is desirable to communicate with an asset based upon the physical location of the asset. Additionally, a method of determining when an asset is being removed or added to the network is desirable. It would also be desirable to communicate with the device without requiring the device or the asset to be connected to alternating current (AC) power. Such a device would allow a company to track its assets, locate any given asset, and count the total number of identified assets at any given time, thus significantly reducing its TCO of identified assets.

One method that attempted to control the hardware theft aspect of TCO is disclosed in U.S. Pat. No. 5,406,260 issued to Cummings et. al, (hereby incorporated by reference) which discusses a means of detecting the unauthorized removal of a networked device by injecting a low current power signal into each existing communications link. A sensor monitors the returning current flow and can thereby detect a removal of the equipment. This method provides a means to monitor the connection status of any networked electronic device thus providing an effective theft detection/deterrent system.

It would, however, be desirable to provide a further means in which a networked device may also be identified by a unique identification number using the existing network wiring or cabling as a means of communicating this information back to a central location. More particularly, it is desirable to provide a means for identification that feasibly employs the same cable (and, if desired, the same wires in the cable) that normally carries high frequency data communications in an existing network. In addition, it is desirable to provide an identification system that is easily and inexpensively implemented in an existing network system.

The theft of information is a further aspect of TCO. Today, the most important resources a company has are its employees and the information that they create and accumulate. Information that is available on a company's internal network can range from personnel files and corporate business plans to research and development efforts related to new products. Restricting access to sensitive or confidential information such as personnel files is a high priority for all companies. The use of passwords and limiting access to certain types of information to particular computer stations are typical methods that companies employ to protect information. These passive methods of protecting company information are sufficient to prevent technically unknowledgeable people from gaining access to protected information. However, these methods are usually unable to protect information from a technically knowledgeable person with specialized electronic equipment. The existence of an unauthorized device connected to the company network may indicate the presence of someone with electronic equipment that has the capability to defeat a company's internal security measures. A method of blocking communications with such a device connected to a network is desirable. Further, automatically blocking communications with an unauthorized device is desirable. An active system that interrogates the devices connected to a network and blocks communications with unauthorized devices would provide enhanced security for sensitive information.

A further aspect of support costs is the cost associated with utilization of network bandwidth. Today, the bandwidth of most networks is being constantly increased to meet the increasing need to transmit large quantities of data. In order to provide the required bandwidth costly hardware upgrades

3

must be purchased resulting in an increase in the TCO. To reduce the need for hardware upgrades the use of available network bandwidth is dedicated to data that is required for the operation of application programs. Using valuable network bandwidth to provide a means of identifying assets would either limit the availability of bandwidth for application programs or require the purchase of new hardware. Additionally, using network bandwidth for asset identification would limit the identification system to operating only when the asset has AC power applied. Assemblies within the asset would have to be operational in order to transmit data over the network. Requiring power to be applied to every monitored asset would limit the capability to identify all the assets connected to a network at any particular time. Therefore, it is desirable to provide a means for asset identification that does not use existing network bandwidth. Such a device would more fully utilize existing network resources without increasing the TCO associated with network bandwidth.

SUMMARY OF THE INVENTION

In accordance with the teachings of the present invention, a communication system is provided for generating and monitoring data over a pre-existing wiring or cables that connect pieces of networked computer equipment to a network. The system includes a communication device or remote module attached to the electronic equipment that transmits information to a central module by impressing a low frequency signal on the wires of the cable. A receiver in the central module monitors the low frequency data to determine the transmitted information from the electronic equipment. The communication device may also be powered by a low current power signal from the central module. The power signal to the communication device may also be fluctuated to provide useful information, such as status information, to the communication device. Relocation of the electronic equipment with the attached communication device to another location on the network is detected immediately and may be used to update a database. This invention is particularly adapted to be used with an existing Ethernet communications link or equivalents thereof.

BRIEF DESCRIPTION OF THE DRAWINGS

Other objects and advantages of the present invention will become apparent to those skilled in the art upon reading the following detailed description and upon reference to the drawings in which:

FIG. 1 is a general block diagram that illustrates a network that includes a communication system in accordance with a first embodiment of the present invention;

FIG. 2 is an exploded perspective view that illustrates installation of the central module into an existing computer network in accordance with the first embodiment of the present invention;

FIG. 3 is a block diagram that illustrates the first embodiment of the present invention;

FIG. 4 is an interconnection diagram that illustrates a second embodiment of the present invention;

FIG. 5 is a block diagram that illustrates a central module made in accordance with the teachings of the present invention;

FIG. 6 is a detailed schematic diagram of the central module in accordance with the second embodiment of the present invention;

4

FIG. 7 is a block diagram that illustrates a remote module made in accordance with the teachings of the present invention;

FIG. 8 is a detailed schematic diagram that illustrates a central module in accordance with the second embodiment of the present invention;

FIG. 9 is a diagram that illustrates alternate circuits for blocking communications in accordance with an embodiment of the present invention;

FIG. 10 is a detailed schematic diagram which illustrates a remote module and a central receiver module coupled to a network in accordance with the third embodiment of the present invention;

FIG. 11 is a perspective view of one embodiment of the hardware for the remote module;

FIG. 12 is an exploded perspective view of the hardware of FIG. 11;

FIG. 13 is a cross-sectional view of the hardware shown mounted to a computer;

FIG. 14 is a perspective view of an alternative embodiment of the hardware for the remote module;

FIG. 15 illustrates the installation of the hardware of FIG. 14 into a computer;

FIG. 16 is a schematic representation of an electronic tether in accordance with the fourth embodiment;

FIG. 17 is a cross-sectional view of an electronic tether used in connection with the fourth embodiment;

FIG. 18 is a schematic representation of circuitry for the fourth embodiment;

FIG. 19a is a block diagram that illustrates a system for electronically identifying an object made in accordance with the teachings of the present invention;

FIG. 19b is a cross-sectional view of an ID sender tag used in connection with the system for electronically identifying an object;

FIG. 20 is a schematic representation of circuitry used in a system for electronically identifying an object;

FIG. 21 is a perspective view that illustrates installation of an ID sender tag and decoder plug; and

FIG. 22 is a perspective view that illustrates an ID sender tag and decoder plug interconnected by a serial bus.

DETAILED DESCRIPTION OF THE PREFERRED EMBODIMENT

Four embodiments of the invention are illustrated within this specification. The first embodiment illustrates the general teachings of the invention, whereas the second, third, and fourth embodiments depict specific implementations of the teachings. Turning now to FIGS. 1, 2 and 3, a first embodiment of a central module 15 and remote module 16 system is provided therein for achieving identification of electronic computer equipment associated with a computer network 17. Although, the first embodiment depicts merely communicating equipment identification information, the principles of the invention may be readily extended to include the communication of more general information such as identification of the equipment processor type and the equipment harddrive capacity. In general, the central module 15 monitors remote module circuitry 16 that may be permanently attached to remotely located electronic workstations such as personal computers 3A through 3D over the computer network 17. The communication system 15 and 16 described herein is particularly adapted to be easily implemented in conjunction with an existing computer network 17 while realizing minimal interference to the computer network. In addition to being implemented from the hub of a network to remotely located PCs,

5

the invention can be applied to other elements of an office environment such as telephones, fax machines, robots, and printers. The invention is particularly suitable for being incorporated into a patchpanel. The asset aware patchpanel would then be capable of identifying the existence and location of network assets without power being applied to the assets.

Remotely located personal computers 3A through 3D are each connected to the computer network 17 so as to provide widespread remote user access to the computer network 17. The remotely located personal computers 3A through 3D are shown connected to hub 1 via data communication links 2A through 2D. Data communication links 2A through 2D are, for example, conventional multi-wire cables that include a plurality of transmit and receive data communication links (sometimes referred to herein as wires or lines) for communicating information between each of remotely located computers 3A through 3D and other communication devices on the network such as other computers and file servers (not shown).

The invention described herein is particularly suited to be implemented in conjunction with a computer network 17 which preferably employs a conventional wiring approach of the type which may include twisted pair wiring such as Ethernet, Token Ring, or ATM. Wiring schemes similar to Ethernet are commonly employed to provide data communication links for electronic computer equipment. In accordance with conventional wiring or cabling approaches, data communication links 2A-2D generally include a pair of transmit wires (not shown) as well as a pair of receive wires (not shown) connected to each of personal computers 3A through 3D. The cable may include other wires, as well. Each pair of transmit and receive wires are internally coupled to an associated personal computer via two windings of an internally located isolation transformer (not shown). Each pair of transmit wires and each pair of receive wires thereby form a current loop through one of the personal computers 3A through 3D which is advantageously employed in accordance with the approach described herein.

The central module 15 includes an isolation power supply 8 (see FIG. 3) which supplies a continuous direct current (DC) power supply to each of current loops 2A through 2D. The DC power supply has a low current preferably on the order of magnitude of about 1 mA. The isolation power supply 8 includes an input terminal for receiving a low voltage signal V_{LV} which has a magnitude of approximately fifteen (15) volts. The present embodiment of the invention sources DC current from the 15 volt source to the remote modules 16. However, it is within the scope of the invention to provide other voltage levels such as 3V dc, and 20V dc. Although the present embodiment sources current for the immediate power needs of the remote module, it is also within the scope of the invention to supply current to charge a battery, capacitor bank, or other energy storage device that powers the remote module. Additionally, powering the remote module from some other source such as a primary battery, rechargeable battery or capacitor bank that receives energy from a source other than the central module is within the scope of the invention.

The power generated by isolation power supply 8 is passed through signal modulator 7 which can slightly alter the voltage supplied by isolation power supply 8 based upon status data provided by the status data encoder 9. Status data encoder 9 receives its status data from the firmware kernel 4. Signal modulator 7 inserts this low power supply across the transmit and receive lines or into either the transmit lines or the receive lines in order to supply the remote module 16 with both status information and power. The scope of the invention

6

includes transmitting status information as a single bit or as a pulse train. Types of transmitted status information include whether the protection circuit is active, date, time, and port location. It is also within the scope of the invention to encode the status data using methods such as single bit on/off, Manchester, 4B/5B, and Frequency Shift Keying (FSK).

Isolation power supply 13 draws power for the remote module 16 and provides status information that was encoded into the power supply signal by signal modulator 7 within the central module 15. This status information is in turn passed over to the firmware kernel 10 of the remote module 16 by way of the status data reader 14.

Firmware kernel 10 provides a preprogrammed unique identification number to Manchester encoder 11 in order to reliably traverse the data communication link or cable 2A. The Manchester encoder then passes this encoded number to signal transmitter 12 which sends the encoded number across the data communication link 2A by altering the total current draw of the remote module 16. Although the present embodiment of the invention uses Manchester encoding, the principles of the invention may be readily extended to other encoding techniques such as Frequency Shift Keying, 4B/5B, PAM5x5, 8B/6T, Polar NRZ, and Bipolar. Additionally, waveshaping the encoded signal with techniques such as MLT-3 is within the scope of the invention. In addition to transmitting an identification number the firmware kernel 10 may also elect to send additional information such as confirmation of the status information or additional data provided by an external device 18, such as the computer 3A to which the remote module 16 is attached.

The information sent from the remote module 16 is received by the signal receiver 6 within the central module 15, decoded by Manchester decoder 5, and passed on to the firmware kernel 4. The firmware kernel may now pass this received information on to an external device 19, such as a computer responsible for asset tracking.

Kernel 4 may optionally provide a blocking signal to blocking circuit 20 to deny, to an unauthorized computer, access to the network information via hub 1. For example, if someone uses a laptop to attempt to plug into the network, the central module 15 detects the absence of the proper identification code from the laptop and, as noted before, kernel 4 would issue a suitable signal to blocking circuit 20 to prevent access to the network information and also generate an alarm. Furthermore, if the potential thief later disconnects protected equipment from the network, this action is also detected and an alarm can be generated. Although the present embodiment illustrates the blocking function as shorting the data lines together 131 (see FIG. 9), it is within the scope of the invention to implement blocking by other means, such as opening both lines of the transmit or receive data lines 130, opening one of the data lines 132, and transmitting noise onto the data lines 134.

FIGS. 4-8 illustrate a second embodiment of the invention which generally differs from the first embodiment by having circuitry that transmits a modulated signal directly to central module 15a from remote module 16a. In the first embodiment current sourced from central module 15 to remote module 16 is modulated within remote module 16 and then returned to central module 15. In addition, the second embodiment does not have a status data reader 14 in remote module 16a, but does additionally include test voltage source 64 and test voltage monitor 66 and 84 pairs in the central module 15a. Referring to FIG. 4 a network 17a that includes the communication system is shown. Hub 1 connects to central module 15a, which connects to remote module 16a, which connects to PC 3A. Also connected to central module 15a and remote module

16 are external devices 19 and 18. Although the central module 15a and remote module 16a are each shown connected to a single external device it is within the scope of the invention to connect multiple external devices to the modules 15a and 16a. Some of the external devices that are envisioned include motion detectors and glass breakage detectors.

Referring to FIGS. 5 and 6, the central module 15a is depicted. A receive pair of conductors from the hub 1 pass through connector 67 (FIG. 6) and connect to blocking circuit 20, test voltage source 64, and test voltage monitor 66. A +15 volt source with series resistor 65 comprises test voltage source 64. A comparator 68 with a resistor divider circuit comprises the test voltage monitor 66. Diode 70 connects from the divider circuit to the power input of comparator 68 to suppress voltage transients at the input to comparator 68. A low power TLC2274ACD is employed for comparator 68 of the present embodiment. The test voltage source 64 and test voltage monitor 66 pair monitor the receive conductors to ensure the hub 1 is connected to central module 15. Blocking circuit 20 includes high pass filter 60, relay 61, and high pass filter 62 which connects to a receive pair of conductors from the remote module 16. High pass filter 62 also connects internally to signal receiver 6. High pass filters 60 and 62 block DC current flow and isolate the relay 61 from driver circuits of hub 1 and PC 3A to enable the central module 15a to continue to monitor the conductors from the remote module 16a. Signal receiver 6 comprises an isolation transformer 72, low pass active filter 74, and comparator 76. The output of comparator 76 is decoded by Manchester decoder 5 and then sent to firmware kernel 4. A processor 77 is employed to implement the kernel 4 and status data encoder 9 functions. The processor 77 in the illustrated embodiment is a Microchip PIC16C62. Internal to the processor 77 data received from internal and external signals is encoded and then outputted to signal modulator 7 which comprises NPN transistor 78 and PNP transistor 80 arranged in a level shifter configuration. The output of signal modulator 7 is diode OR'd with the output of isolation power supply 8 and then connects to one of the transmit data lines that connect to remote module 16. The return path for current from PC 3A is the pair of receive data lines. Test voltage monitor 84 operates in a manner similar to test voltage monitor 66 to ensure PC 3A is physically attached to the network 17. Firmware kernel 4 controls the operation of blocking circuit 88 which is connected across the transmit data lines that connect to hub 1. High pass filter 86 blocks DC current from flowing to hub 1 from signal modulator 7 and additionally provides isolation between blocking circuit 88 and the drivers of PC 3A. Connector 90 provides the interface for signals from central module 15a to the cable that interfaces with remote module 16a.

Referring to FIGS. 7 and 8, the remote module 16a of the second embodiment is illustrated. The receive data lines from central module 15a pass through connector 101 (FIG. 8) and connect to high pass filter 100 and signal transmitter 12. High pass filter 100 blocks the DC current that flows from central module 15a from flowing into the input circuit of PC 3A. Signal transmitter 12a, which comprises resistors 104 through 109 and bypass capacitor 110, impresses across the receive data lines a variable current source that is controlled by firmware kernel 10. Connected to a transmit line is isolation power supply 13 which receives power from central module 15a. The isolation power supply 13 comprises resistor 112, filter capacitor 113, and zener diode 114. The regulated voltage developed across zener diode 114 provides power for firmware kernel 10 as well as a number of pull-up resistors. Although a Microchip PIC12C508 processor is employed for firmware kernel 10 in the illustrated embodi-

ment, there are numerous other devices from manufacturers such as SGS Thompson and Burr-Brown that may be employed. The outputs from remote module 16a pass through connector 116 which connects to PC 3A.

Referring to FIGS. 4 and 5, the operation of the second embodiment will be described. The existence of a connection between hub 1 and central module 15a is monitored by test voltage source 64 and test voltage monitor 66 through a pair of receive data lines. Current from test voltage source 64 flows through a data line to an isolation transformer within hub 1. The current flows through the primary winding of the isolation transformer and returns on the other receive data line to the test voltage monitor 66. An interruption in the flow of current is detected by the test voltage monitor 66. A detailed description of the operation of test voltage source 64 and test voltage monitor 66 is provided in U.S. Pat. No. 5,406,206 which is hereby incorporated by reference. Similarly, current sourced onto a transmit line from signal modulator 7 and isolation power supply 8 through remote module 16a to the isolation transformer of PC 3A which returns on the other transmit line is monitored by test voltage monitor 84 to verify that both remote module 16a and PC 3A are connected to central module 15a. Signal modulator 7 additionally supplies power to remote module 16a. A signal from firmware kernel 4 controls NPN transistor 78 which likewise controls level-shifting PNP transistor 80. When PNP transistor 80 is ON, 20 volts is sourced onto the transmit line. When transistor 80 is OFF, 15 volts is sourced onto the transmit line. Referring to FIG. 8, the sourced power from central module 15a flows through resistor 112 and into zener diode 114 and capacitor 113 which provide a regulated voltage to the circuit. In this embodiment the status data transmitted from the central module 15a is not decoded. However, it is within the scope of the invention to receive the encoded data by monitoring various signals, such as the voltage amplitude of the data line relative to ground, the voltage across resistor 112, and the current through resistor 112.

In response to external signals as well as internally programmed routines, the firmware kernel 10 outputs a signal to Manchester encoder 11. A processor 102 incorporates both the kernel 10 and Manchester encoder 11 functions. In the illustrated embodiment a Motorola PIC12C508 is employed as processor 102. The output of the processor 102 is a Manchester encoded signal that drives the balanced resistor network that comprises signal transmitter 12a. A capacitor 110 and resistors 106 and 107 can be added to signal transmitter 12a to provide increased filtering of high frequency components. However, the embodiment does not require their addition as firmware control and line capacitance provide sufficient attenuation to prevent the encoded signal from interfering with normal network communications. The encoded signal flows through resistors 104 and 105 onto the receive data lines to central module 16. High pass filter 100 prevents the encoded signal from being conducted through the receive data lines to PC 3A. Although the encoded signal in the present embodiment transmits the encoded signal from the remote module 16a, it is within the scope of the invention to source current from the central module and alter the flow of current from within the remote module 16a by changing the impedance of a circuit connected across the data communication link 2A. Examples of such circuits include an RC network connected directly to the data link 2A and reflecting an impedance change across an isolation transformer.

Referring again to FIG. 6, the encoded signal is received in the central module 15a by signal receiver 6. Within central module 15a, high pass filter 62 prevents the encoded signal from being conducted through the data lines to hub 1. The

signal couples through transformer 72 to low pass active filter 74 which filters out normal network communications signals. The filtered signal is squared-up by comparator 76 and outputted to Manchester decoder 5. The decoded signal is inputted to firmware kernel 4 which evaluates the information. If the signal represents the port ID or wall jack location, the kernel 4 outputs a signal to external device 19. If the signal provides identification of remote module 16, the kernel 4 compares the received identification with the expected identification. If an invalid identification is received, the firmware kernel 4 sends signals to blocking circuits 20 and 88 commanding them to short the receive data lines together and the transmit data lines together. The kernel 4 additionally sends an alarm notifying external device 19 that an invalid identification has been received. Although the embodiment passes a single signal through the decoder circuit, it is within the scope of the invention to feed encoded signals from multiple sources through a multiplexer into a single decoder circuit, or to implement the decode function in firmware or software, or to multiplex the outputs of multiple decoder circuits. It is also within the scope of the invention to couple the signal from the receiver data lines through an isolating device into a micro-processor wherein the low pass filtering and decoding functions are implemented. Envisioned isolating devices include devices such as transformers, opto-isolators, and balanced operational amplifier circuits. Additionally, it is within the scope of the invention to integrate all the functions of the remote module into a processor that interfaces either directly to the data lines or through an isolating device.

A third embodiment of the invention is illustrated in FIG. 10 which generally differs from the earlier described embodiments by illustrating in detail a circuit as described in the first embodiment wherein current that is sourced through a current loop extending from central module 15b to remote module 16b is modulated in remote module 16b and then decoded in central module 15b. The embodiment comprises a central module 15b and remote module 16b that are connected within an existing network 17b. The central module 15b comprises a test voltage source 117 and a receiver circuit 119. The test voltage source 117 includes a +15 volt source with series resistor 118 for sourcing current onto a transmit data line. The receiver circuit 119 comprises a signal receiver 6, a Manchester decoder 5, and firmware kernel 4b, for receiving and decoding the return current from the receive data lines.

Remote module 16b includes an isolation power supply 13 that regulates and filters power that is received from central module 15b over a pre-existing cable. The isolation power supply 13 supplies regulated power to a processor 122 and circuitry that comprises the signal transmitter 12b. The processor 122 employed in the illustrated embodiment is a Microchip PIC12C508. The processor 122 and exclusive OR gates 120 and 121 implement both the firmware kernel 10 and Manchester decoder 11 functions. An isolation transformer 124, bypass capacitor 110, and resistors 126-129 comprise the signal transmitter 12b which modulates the current from isolation power supply 13 that returns to central module 15b. Capacitors 130 and 132 comprise a high pass filter that blocks the transmitted signal from interfering with normal network communications.

Continuing to refer to FIG. 10, the operation of the third embodiment will be described. Within central module 15b, power flows from the +15 volt source through series resistor 118 and a transmit data line, to the isolation power supply 13 in remote module 16b. Within remote module 16b, power from the transmit data line is regulated by zener diode 114 and filter capacitor 113. The current which flows through resistor 112 splits, with a portion flowing through processor 122 and

the exclusive OR gates, and the remainder flowing through zener diode 114. The return current flowing out of zener diode 114 and the circuit ICs, flows into the secondary winding center-tap of isolation transformer 124. The current splits between the windings with the reflected primary impedance controlling the magnitude of the current that flows in each winding. The primary impedance is controlled by processor 122, the exclusive OR gates 120 and 121, and the two 10 k resistors 126 and 127. A high logic level output from exclusive OR 120 results in current flowing through resistor 126, the primary of isolation transformer 124, resistor 127, and into exclusive OR 121. The current flowing through the transformer primary is reflected to the secondary where it adds with current flowing through one winding and subtracts from current flowing through the other winding. The direction of the current flowing through the primary changes as the output of exclusive OR 120 alternates between a logic level high and low in response to the Manchester encoded stream from processor 122. The variation in primary current flow direction added to the secondary current flowing into the center-tap results in a modulated current signal. The high frequency components of the resulting secondary winding current flow through bypass capacitor 110. The low frequency components flow through resistors 128 and 129, onto the receive data lines, to the central module 15b, and through isolation transformer 72 to signal ground. Resistors 128 and 129 provide a buffer to prevent the bypass capacitor 110 from loading down the data lines.

Within central module 15b, the modulated current is reflected from the primary to the secondary of isolation transformer 72. Low pass active filter 74 filters out high frequency network communication components and passes a squared-up output to the Manchester decoder 5. The decoded data stream is inputted to the firmware kernel 4 which evaluates the data stream to ensure a valid identification number was transmitted.

Referring to FIG. 18, a presently preferred embodiment, the fourth embodiment, of the invention is illustrated. The fourth embodiment differs from the earlier described embodiments by employing an interface amplifier for the signal receiver 6c in place of an isolation transformer, adding a third source voltage to central module 15c, adding a NIC Stick 170, reconfiguring the signal transmitter of the remote module 16c, and adding an electronic tether 150. The signal receiver interface amplifier is configured as a bandpass filter using design techniques that are well known in the art. The output of the interface amplifier is connected to the processor 77 wherein the signal is decoded. The NIC Stick 170 provides an improved method of interconnecting the signals that flow between the various modules of the preferred embodiment. The NIC Stick 170 and remote module 16c are integrated into a connector assembly for interconnect to a PC. The purpose and function of the tether 150 is provided in a subsequent section of this specification.

Turning now to FIGS. 11-13 the remote module 16 is illustrated as being contained in a special box-like housing 23. The electronics are mounted on a suitable card 22 within the confines of a container 24. The container 24 is mounted to the computer 3A using the existing fasteners normally found on the back of the computer. Such a fastener is illustrated at 26. The fastener 26 is chosen to be one that is required to be removed in order to gain access to the hardware inside the computer. Therefore, the potential thief must remove fastener 26 to steal the mother board, network identification card (NIC), etc. Lid 32 likewise contains opening 34. When the lid is closed as shown in FIG. 13, the opening 28 is aligned with opening 34. These openings allow the normal network wire

connector 38 to pass through the openings in housing 23 and engage the electronics card 22. Housing 23 includes an output cord 40 with a connector 42 which engages the standard network interface card (NIC) found in the computer. This construction is designed to require the potential thief to disconnect connector 38 from housing 23 in order to gain access to the fastener 26 which must be unscrewed in order to remove the internal computer parts. When the connector 38 is removed, the computer 3A becomes, likewise, disconnected from the network. This causes the current in loop 2A to drop below a threshold level which causes the system 15 to cause a system alarm or the like to be activated. Thus this housing configuration deters theft of the internal parts of the computer since fastener 26 must be removed to gain access to them, as well as deterring removal of the entire computer terminal.

FIGS. 14-15 show an alternative embodiment in which the electronics for network identification circuitry 16 are instead placed upon a card 44 which can be inserted into an adjacent slot in the computer next to the standard NIC card 46. The network wire connector 38 is connected to the input of card 44 and the output of identification card 44 is then connected to the normal input receptacle 48 of NIC card 46. It is also envisioned that the electronics of the network identification circuitry can be placed on a motherboard within the computer or as part of the circuitry on the NIC card.

FIG. 16 shows a schematic of another implementation in which the electronic tether 150 extending from the remote module 16 is attached to equipment to be protected. The remote module 16 monitors the status of the tether 150 and notifies the central module 15 if the tether 150 is removed or the electrical connection interrupted. The central module then sets a system alarm either centrally or locally. The tether 150 includes two conductive lines 152 and 154 coupled between a pair of connectors 156 and 158. An attachment status signal is conducted through the conductive lines 152 and 154 for indicating whether the tether 150 remains attached to the protected equipment. The first conductive line 152 includes pads P1 and P2 inline to provide a means of shorting a break in the line. The second conductive line 154 is coupled directly between the connectors. An external jumper 160 is connected to the output connector 158 of the tether 150 to complete the electrical connection.

FIG. 17 illustrates the electronic tether 150 mounted to the surface of equipment to be protected. A conductive pad 162 having conductive adhesive on both sides is bonded to the equipment surface. The adhesive on the side facing the equipment has greater strength than the adhesive on the side facing the tether. The relative strength of the adhesive on either side of the conductive pad 162 is chosen to ensure that if the tether 150 is removed the conductive pad 162 will remain bonded to the equipment, not to the tether. The tether 150 is bonded to the conductive pad 162 so that the pads, P1 and P2, make electrical contact with the conductive pad 162.

In operation, the tether 150 is bonded to a piece of equipment to be protected such as monitors, printers, fax machines, and chairs. Multiple tethers can be connected in series to provide protection for more than one piece of equipment. The remote module 16 monitors the status of the attachment status signal from the tether 150 to determine that an electrical short is maintained. An interrupted attachment status signal indicates that either a tether 150 is no longer connected to its associated piece of equipment or the electrical connection to the tether 150 has been interrupted. Upon detecting an interrupted attachment status signal, the remote module 16 sets a bit of the identification number that is transmitted to the central module 15. The central module 15 then sets an alarm either locally or centrally.

From the foregoing it will be understood that the invention provides a system for communicating with electronic equipment on a network. The system transmits a signal over pre-existing network wiring or cables without disturbing network communications by coupling a signal that does not have substantial frequency components within the frequency band of network communications. The system is particularly suitable for high-frequency networks such as Ethernet operating at speeds of 10 megabits per second (Mb/s) and higher. For purposes of this invention the term "high frequency information" means the band of frequencies needed to carry data at 10 Mb/s or more. Coupling a lower frequency signal to the data lines of such a network permits increased utilization of the available transmitting medium without a commensurate increase in the cost of the network. To ensure that the added lower frequency signal does not interfere with normal network communications the added signal must not contain frequency components that interfere with the network signals. For example, when the invention is used with an Ethernet 10BASE-T network, the specifications for that network method place stringent restrictions on the behavior of the medium for frequencies from 5 MHz to 10 MHz with some parameters specified to frequencies as low as 1 MHz. In the present embodiment a simple highpass circuit at 150 kHz formed by adding capacitors into each wire of the medium is employed to isolate the injected signal from normal network communications, resulting in substantially no disruption of the high frequency network information. Additionally, employing a higher order high pass filter would permit operation with less disruption than a lower order high pass filter at the same corner frequency. For the purposes of the invention, the term "low frequency signal" means signals in which the energy representing the data can be reliably carried in the band of frequencies made available by this filtering. Typically, this means that the low frequency signals operate at a bit rate which is less than about 1% of the bit rate of the high frequency signals which carry the network communication data. By way of a specific example, the high frequency information in the embodiment of FIGS. 4-8 operates in the range of about 10 Mb/s while the encoded signal sent from remote module 16a to central module 15a operates in the range of about 1200 bits per second. In other words, the altered current flow has changes and each change is at least 833 microseconds in duration ($1/1200=0.000833$ seconds). Although the present embodiment operates in the range of about 1200 bits per second, it is within the scope of the invention to operate at bit rates up to 57.6 kb/s by increasing the filter frequencies, operating in a lower noise environment, or increasing the degradation of network communications. Further suppression of harmonics results from the lowpass filtering provided by the resistors used to couple the low frequency signal to the data lines acting with the capacitors used for the highpass function mentioned above.

Additionally, the system provides a means for permanently identifying the location of network assets without applying power to the assets. Also, the system can be employed to determine asset inventory, i.e. when an asset is being removed or added to the network. The system permits a company to track its assets, locate any given asset, and count the total number of identified assets at any given time. In addition, the system provides a means of blocking communications with an unauthorized device that is connected to the network. Furthermore, the system allows the automatic blocking of communications with an unauthorized device. Additionally, the system is particularly suitable to be integrated into an asset aware patchpanel in order to provide a means for identifying the location of network assets.

Referring to FIGS. 21 and 22, a system 200 for communicating with equipment is illustrated. The system provides a means of assigning a permanent electronic identification number to an object. The object electronic number is used to monitor the configuration of the object, to control access to network entities such as programs and servers, and to provide network management information. The initial configuration of a network device is stored and referenced in a network database by the object identification number, permitting subsequent comparisons between the initial configuration and the subsequent configuration of the network device. Another permanent electronic number may be assigned to the physical location of the object. The location electronic number combined with the object electronic number provides simultaneous references for location and configuration of an object. The network database further includes the location associated with the location identification number, thereby permitting between the initial location and configuration, and the subsequent location and configuration of an object. The system 200 includes an ID sender tag 202 that has a unique identification number and is physically attached to an object 204. In the preferred embodiment the identification number is programmed at manufacture and is not changeable. Once the ID sender tag 202 is attached to an object, the identification number becomes associated with that object 204. In the presently preferred embodiment of the invention, a first sender tag 202 is attached to a computer 204a and a second sender tag 202 is attached to a wall 204d near the computer 204a. However, other objects are within the scope of the invention, such as desks 204b, monitors 204c, computer pointing devices, other computers (powered and unpowered), and clothing. The first sender tag 202 provides identification information and the second sender tag 202 provides location information. Each sender tag 202 transmits a serial stream that includes a unique identification number corresponding respectively to the computer 204a and the wall 204d. A decoder plug 206 attached to a computer port is electronically coupled to the sender tag 202. The decoder plug 206 receives the serial stream, and then converts the serial stream into a signal format that is compatible with the port to which the decoder plug 206 is connected. Although, in the presently preferred embodiment the decoder plug 206 is connected to a computer parallel port 210, the principles of the invention may be readily extended to other types of ports, such as USB, Firewire, keyboard, and serial ports. In addition, the scope of the invention includes coupling multiple ID senders 202 to a single decoder plug 206 so that multiple objects can be monitored with the decoder plug 206. Also, connecting multiple decoder plugs 206 in series is within the scope of the invention. The decoder plug 206 includes an identification number, thereby permitting the interconnected decoder plugs 206 and ID sender tags 202 to be logically linked together. The parallel port 210 is included within the computer 204a, which is connected to a network 212. Referring to FIG. 19a, a port reader 218 in the computer 204a reads the converted serial stream at the parallel port 210 and sends the communicated information over the network 212. The scope of the invention includes employing pre-existing collector software as an interface to the port reader for communicating with the decoder plug 206. A server 214 connected to the network 212, includes a control manager 216 that receives and analyzes the communicated information. The control manager 216 includes a database for storing communicated information such as initial and subsequent locations and configurations for identified objects. Although the presently preferred embodiment of the invention includes a port reader 218 and a control manager 216, the principles of the invention may be

practiced with merely an ID sender tag 202 electronically coupled to a decoder plug 206.

Referring to FIG. 19b in addition to FIG. 19a, the mounting configuration of the sender tag 202 is illustrated. A mounting arrangement similar to that of the electronic tether 150 described in an earlier section of this specification is employed to mount the sender tag 202 to the surface of an object. The sender tag 202 includes pads 205 for mounting. A conductive pad 203 having conductive adhesive on both sides is bonded to the pads 205 for attaching the sender tag 202 to an equipment surface. The adhesive on the side facing the equipment has greater strength than the adhesive on the side facing the pads 205. The relative strength of the adhesive on either side of the conductive pad 203 is chosen to ensure that if the sender tag 202 is removed the conductive pad 203 will remain bonded to the equipment, not to the pads 205 of the sender tag 202. With the conductive pad 203 attached to the sender tag 202 an electrical connection is established between the pads 205.

Referring to FIG. 20 in addition to FIG. 19a, the ID sender tag 202 of the presently preferred embodiment is illustrated. The ID sender tag 202 is a physical identifier that has an identification number that is programmed at manufacture. The identification number is remotely readable through a communication interface that is continuously operable and parasitically powered. The ID sender tag 202 includes a processor 220 for Manchester encoding and sending the identification number over the attached serial bus. Although, Manchester encoding is employed in the preferred embodiment, other forms of transmitting a serial stream are within the scope of the invention, such as single bit on/off, 4B/5B, Frequency Shift Keying (FSK), and techniques that result in a DC bias on the line. Regulating and filtering the power for the processor 220 is provided by circuitry that is configured using design techniques that are well known in the art. Additionally, a set of resistors is selected using design techniques that are well known in the art to buffer the output of the processor 220 from the serial bus. The firmware of processor 220 is programmed to provide an ID manager 222 function. The ID manager 222 generates an identification packet using procedures for Manchester encoding and RS232 framing of a unique identification number. Table I includes pseudocode of the procedures carried out by the ID manager 222.

TABLE I

| Pseudocode for ID Manager | |
|---------------------------|---|
| | Retrieve the data words containing the identification number. |
| | Load the data words containing the identification number into RAM. |
| 50 | Begin Encode Loop |
| | Begin transmitting information. |
| | Set the start bit to begin the first half of the Manchester cycle. |
| | Load a data word |
| | Pad out time and set the end bit. |
| | Set the start bit to begin the second half of the Manchester cycle. |
| 55 | Load a data word. |
| | Pad out time and set the end bit. |
| | Set RS-232 framing |
| | Loop until the packet is complete |

Referring to FIG. 20 in addition to FIG. 19a, the decoder plug 206 of the presently preferred embodiment is illustrated. The decoder plug 206 is a physical reader that has an identification number that is programmed at manufacture. The continuously operable and parasitically powered communication interface permits the decoder plug 206 to remotely read the identification number of an attached ID sender 202. The decoder plug 206 includes a signal receiver 230, a processor

232, and a voltage regulator 234. The signal receiver 230 provides a balanced impedance on the serial bus for receiving the serial stream from the sender tag 202. The buffered serial stream is coupled from the output of the signal receiver 230 to an input of the processor 232 which converts it into a parallel stream. Firmware in the processor 232 implements an ID reader module 236 to provide the conversion function. A tri-state buffer 233 coupled to the processor 232 permits unobstructed passthrough communication from the interface port 210 to a peripheral device coupled to the decoder plug 204 through a connector 235. Power, Vcc, from the parallel port is regulated by the voltage regulator 234 and used to power the processor 232 and signal receiver 230. Table II provides pseudocode of the ID reader module 236.

TABLE II

Pseudocode for ID Reader Manager

Load the Manchester encoded data.
 Perform a majority sample decode (converts the Manchester symbols to a bit stream)
 Strip the start and end bits.
 Output a series of bytes.
 Assemble the bytes into a message.
 Perform error and checksum testing.
 Store the message.

In operation, the communication system has multiple operating modes, such as asset control mode, network management information mode, and license control mode. In asset control mode the system provides external identifiers as a guaranteed reference for computer change control including change of location and change of configuration. During network management information mode the system automates the physical management and inventory of equipment. In license control mode the system trades access to the computer in exchange for a physical inventory of the connected identifiers.

With reference to FIGS. 19a and 20, during asset control mode the control manager 216 located in the server 214 sends an asset identifier request to the port reader 218 requesting the identification number of equipment that is monitored by the computer 204a. The asset identifier request is passed through the decoder plug 206 to each of the ID sender tags 202 that are associated with the computer 204a. The ID manager 222 in each ID sender tag 202 Manchester encodes a predefined identification number and transmits the encoded number to the decoder plug 206 as a serial stream with RS-232 framing. The ID reader module 236 in the decoder plug 206 performs a majority sample decode to convert the Manchester symbols to a bit stream. In addition, the reader module 236 provides the equivalent of a UART by stripping the start and end bits and outputting a series of bytes. The bytes are then assembled into an ID sender message and stored after appropriate error and checksum testing. The decoder plug 206 then formats the stored sender messages for transmission to the interface port 210. First, a decoder message is assembled, consisting of identification information related to the decoder plug 206, status information, and the stored sender messages. Second, a MAC/physical layer which handles the interface and handshaking to the interface port 210 is constructed. The decoder plug 206, then transmits the assembled decoder information to the interface port 210. The port reader 218 receives the assembled decoder information, reformats the enclosed messages and transmits the reformatted messages to the control manager 216. The control manager 216 evaluates the response from the computer 204a. The evaluation by the

control manager 216 includes comparing and updating the configuration and location information of the queried objects with previously stored information in the associated database. The initial physical identity and initial physical location of an object is input to the database during setup of an ID sender tag 202 by an operator such as a user. Information related to the object is also inputted to the database. Related object information includes the object serial number, physical attributes, physical configuration, electronic attributes, software configuration, network attributes, and date of entry.

Continuing to refer to FIGS. 19a and 20, during network management information mode a network manager determines the location or configuration of assets that are coupled to the network by interrogating ID senders 202 and decoder plugs 206 attached to assets. The system is especially useful for token ring and fiber optic networks since the location information related to an object is provided by an ID sender tag 202 attached to a relatively immobile surface rather than reading a port address associated with a network device. The method of interrogating the ID sender tags 202 is similar to that employed during asset control mode except asset configuration information is requested instead of merely identification of attached objects.

During license control mode a key manager located in server 214 limits access to selected programs to predetermined assets or a quantity of assets rather than to predetermined users or a quantity of users. In response to a user attempting to open a controlled program, the key manager ascertains the asset the user is employing and the identification number assigned to the asset in a similar manner to that described for asset control mode. The key manager then employs access criteria to determine whether to grant access to the controlled program.

Although, in the preferred embodiment the comparison function of the control manager and database is executed on a network server electronically coupled through a network to an ID sender tag 202, the scope of the invention includes conducting the comparison locally on a computer that is being scanned, in a central database over a network, over a corporate intranet, and over the world wide Internet.

In operation, an application which runs "Java" through a standard browser is provided. A requestor connected to the Internet selects a button to request related object information from an Internet connected object. In response to the request, an ActiveX (Java) control gets pulled down onto a computer connected to the object, runs and reads the object identification number and the object location identification number from ID sender tags 202. The computer reports the related object information back to the requester over the Internet.

From the foregoing it will be understood that the invention provides a system and method for remotely detecting and reading an asset identity and location. Additionally, the system and method can be employed to automate collection and validation of asset identity and location. The system and method provide a means for communicating with an asset based on identity or location. In addition, the system and method permit the automated comparison and storage of asset configuration and location information. Also, the system and method can be employed to automate asset change control. Additionally, the system and method provide a means to perform asset management, remote identification, and remote access security over the Internet in a guaranteed fashion.

The attachment of a remote module 16 or an ID sender tag 202 to an object provides an identification number corresponding to the object. The location of an object with an attached remote module 16 is provided by the corresponding port address associated with the object. The location of an

object with an attached ID sender tag **202** is provided by an associated ID sender tag **202** that is attached to a surface of a wall, floor, or other relatively immobile object.

It should be understood that while this invention has been described in connection with particular examples thereof, no limitation is intended thereby since obvious modifications will become apparent to those skilled in the art after having the benefit of studying the foregoing specification, drawings and following claims.

What is claimed is:

1. A piece of Ethernet terminal equipment comprising: an Ethernet connector comprising first and second pairs of contacts used to carry Ethernet communication signals, at least one path for the purpose of drawing DC current, the at least one path coupled across at least one of the contacts of the first pair of contacts and at least one of the contacts of the second pair of contacts, the piece of Ethernet terminal equipment to draw different magnitudes of DC current flow via the at least one path, the different magnitudes of DC current flow to result from at least one condition applied to at least one of the contacts of the first and second pairs of contacts, wherein at least one of the magnitudes of the DC current flow to convey information about the piece of Ethernet terminal equipment.
2. The identifiable piece of Ethernet terminal equipment of claim **1** wherein the piece of Ethernet terminal equipment is a personal computer.
3. The piece of Ethernet terminal equipment of claim **1** wherein the first pair of contacts consist of contacts **1** and **2** and the second pair of contacts consist of contacts **3** and **6**.
4. The piece of Ethernet terminal equipment of claim **1** wherein the Ethernet connector is an RJ45 jack connector.
5. The piece of Ethernet terminal equipment of claim **1** wherein the Ethernet communication signals are BaseT Ethernet communication signals.
6. The piece of Ethernet terminal equipment of claim **1** wherein the at least one path is integrated into the piece of Ethernet terminal equipment.
7. The piece of Ethernet terminal equipment of claim **1** wherein the at least one path is attached to the piece of Ethernet terminal equipment.
8. The piece of Ethernet terminal equipment of claim **1** wherein the at least one path comprises at least one center tap of at least one isolation transformer.
9. The piece of Ethernet terminal equipment of claim **1** wherein the at least one of the contacts of the first pair of contacts consists of both of the contacts of the first pair of contacts and the at least one of the contacts of the second pair of contacts consists of both of the contacts of the second pair of contacts.
10. The piece of Ethernet terminal equipment of claim **1** wherein the at least one path comprises at least two paths coupled across at least one of the contacts of the first pair of contacts and at least one of the contacts of the second pair of contacts.
11. The piece of Ethernet terminal equipment of claim **1** wherein at least one of the first and second pairs of contacts is actually carrying Ethernet communication signals.
12. The piece of Ethernet terminal equipment of claim **1** wherein the piece of Ethernet terminal equipment is actually drawing the DC current via the at least one path.
13. The identifiable piece of Ethernet terminal equipment of claim **1** wherein the piece of terminal equipment is physical connected to a central piece of network equipment.
14. The piece of Ethernet terminal equipment of claim **1** wherein the at least one path is electrically coupled.

15. The piece of Ethernet terminal equipment of claim **1** wherein the at least one path is physically coupled.

16. The piece of Ethernet terminal equipment of claim **1** wherein the piece of Ethernet terminal equipment to draw different magnitudes of DC current flow via at least one of the contacts of the first and second pairs of contacts of the Ethernet connector.

17. The piece of Ethernet terminal equipment of claim **1** wherein cessation in the flow of the DC current to indicate physical disconnection of the piece of Ethernet terminal equipment from a central piece of network equipment.

18. The piece of Ethernet terminal equipment of claim **1** wherein the flow of the DC current to indicate physical connection of the piece of Ethernet terminal equipment to a central piece of network equipment.

19. The identifiable piece of Ethernet terminal equipment of claim **1** wherein at least two different magnitudes of the DC current to convey information about the piece of Ethernet terminal equipment.

20. The piece of Ethernet terminal equipment of claim **1** wherein the different magnitudes of DC current comprise a series of magnitudes.

21. The piece of Ethernet terminal equipment of claim **1** wherein the different magnitudes of DC current flow to occur at regular intervals.

22. The piece of Ethernet terminal equipment of claim **1** wherein the at least one condition comprises a voltage condition.

23. The piece of Ethernet terminal equipment of claim **1** wherein the at least one condition comprises an impedance condition.

24. The piece of Ethernet terminal equipment of claim **1** wherein the different magnitudes of DC current flow to result from at least one condition across the at least one path.

25. The piece of Ethernet terminal equipment of claim **24** wherein the at least one condition comprises a voltage condition.

26. The piece of Ethernet terminal equipment of claim **24** wherein the at least one condition comprises an impedance condition.

27. The piece of Ethernet terminal equipment of claim **1** wherein the different magnitudes of DC current flow to result from at least one condition across the at least one of the contacts of the first pair of contacts and the at least one of the contacts of the second pair of contacts.

28. The piece of Ethernet terminal equipment of claim **27** wherein the at least one condition comprises a voltage condition.

29. The piece of Ethernet terminal equipment of claim **27** wherein the at least one condition comprises an impedance condition.

30. The piece of Ethernet terminal equipment of claim **1** wherein the piece of Ethernet terminal equipment to continuously draw the DC current via the at least one path.

31. The piece of Ethernet terminal equipment of claim **1** wherein the DC current comprises a predetermined range of magnitudes.

32. The piece of Ethernet terminal equipment of claim **1** wherein the DC current comprises continuous DC current.

33. The piece of Ethernet terminal equipment of claim **1** wherein the information comprises electrical information.

34. The piece of Ethernet terminal equipment of claim **33** wherein the electrical information is related to an electrical aspect of the piece of Ethernet terminal equipment.

35. The piece of Ethernet terminal equipment of claim **1** wherein the information comprises physical information.

36. The piece of Ethernet terminal equipment of claim 35 wherein the physical information to comprise physical configuration of the piece of Ethernet terminal equipment.

37. The piece of Ethernet terminal equipment of claim 35 wherein the physical information is related to a physical aspect of the piece of Ethernet terminal equipment.

38. The piece of Ethernet terminal equipment of claim 1 wherein the information is encoded.

39. The piece of Ethernet terminal equipment of claim 38 wherein the information is Manchester encoded.

40. The piece of Ethernet terminal equipment of claim 1 wherein the information to comprise general information about the piece of Ethernet terminal equipment.

41. The piece of Ethernet terminal equipment of claim 40 wherein the general information is related to hard drive capacity.

42. The piece of Ethernet terminal equipment of claim 40 wherein the general information is related to processor type.

43. The piece of Ethernet terminal equipment of claim 1 wherein the information to distinguish the piece of Ethernet terminal equipment from at least one other piece of Ethernet terminal equipment.

44. The piece of Ethernet terminal equipment of claim 1 wherein the information to uniquely identify the piece of Ethernet terminal equipment.

45. The piece of Ethernet terminal equipment of claim 1 wherein the information to continuously identify the piece of Ethernet terminal equipment.

46. The piece of Ethernet terminal equipment of claim 1 wherein the piece of Ethernet terminal equipment to detect information about a central piece of network equipment via the DC current.

47. The piece of Ethernet terminal equipment of claim 1 wherein the piece of Ethernet terminal equipment comprises at least one blocking capacitor.

48. The piece of Ethernet terminal equipment of claim 47 wherein the at least one blocking capacitor to block the flow of the DC current through a path across the contacts of the Ethernet connector.

49. The piece of Ethernet terminal equipment of claim 47 wherein the at least one blocking capacitor to direct the flow of the DC current through a path across of the contacts of the Ethernet connector.

50. The piece of Ethernet terminal equipment of claim 1 wherein the piece of Ethernet terminal equipment comprises one or more electrical components.

51. The piece of Ethernet terminal equipment of claim 50 wherein the one or more electrical components comprise a transmitter.

52. The piece of Ethernet terminal equipment of claim 50 wherein the one or more components to change at least one of the different magnitudes of the DC current.

53. The piece of Ethernet terminal equipment of claim 1 wherein a duration of at least one of the different magnitudes of the DC current to comprise a predetermined range.

54. The piece of Ethernet terminal equipment of claim 53 wherein the predetermined range is between 17 and 833 microseconds.

55. The piece of Ethernet terminal equipment of claim 1 wherein the information to identify the piece of Ethernet terminal equipment as a particular piece of Ethernet terminal equipment.

56. The piece of Ethernet terminal equipment of claim 1 wherein the at least one path comprises at least two different impedances.

57. The piece of Ethernet terminal equipment of claim 1 wherein the at least one path comprises a predetermined range of impedance.

58. The piece of Ethernet terminal equipment of claim 1 wherein impedance within the at least one path changes.

59. The piece of Ethernet terminal equipment of claim 58 wherein the impedance within the at least one path continuously changes.

60. The piece of Ethernet terminal equipment of claim 1 wherein the at least one path comprises at least two different paths.

61. The piece of Ethernet terminal equipment of claim 1 wherein the at least one path is a function of at least one electrical condition across at least one of the contacts of the first pair of contacts and at least one of the contacts of the second pair of contacts.

62. The piece of Ethernet terminal equipment of claim 1 wherein the DC current to operate circuitry associated to the piece of Ethernet terminal equipment.

63. The piece of Ethernet terminal equipment of claim 62 wherein the circuitry is integrated into the piece of Ethernet terminal equipment.

64. The piece of Ethernet terminal equipment of claim 63 wherein the circuitry comprises a processor.

65. The piece of Ethernet terminal equipment of claim 63 wherein the circuitry comprises a transmitter.

66. The piece of Ethernet terminal equipment of claim 65 wherein the transmitter is electrically coupled to the at least one path.

67. The piece of Ethernet terminal equipment of claim 63 wherein the circuitry comprises an isolation power supply.

68. The piece of Ethernet terminal equipment of claim 1 wherein the piece of Ethernet terminal equipment is physically connected to a central piece of network equipment via separate Ethernet cabling.

69. The piece of Ethernet terminal equipment of claim 1 wherein a magnitude of the DC current to comprise information to identify the piece of Ethernet terminal equipment.

70. The piece of Ethernet terminal equipment of claim 1 wherein the DC current to comprise first magnitude of DC current for a first interval followed by a second magnitude of DC current for a second interval, wherein the second magnitude is greater than the first magnitude.

71. The piece of Ethernet terminal equipment of claim 70 wherein at least one of the first and second magnitudes of DC current to identify the piece of Ethernet terminal equipment.

72. The piece of Ethernet terminal equipment of claim 1 wherein at least one magnitude of the DC current is part of a detection protocol.

73. The piece of Ethernet terminal equipment of claim 1 wherein the piece of Ethernet terminal equipment is physically connected to a central piece of equipment via an Ethernet cable and the at least one path forms a DC current loop via wires within the Ethernet cable.

74. The piece of Ethernet terminal equipment of claim 1 wherein the at least one path comprises an electrical component.

75. The piece of Ethernet terminal equipment of claim 74 wherein the electrical component is a resistor.

76. The piece of Ethernet terminal equipment of claim 1 wherein the at least one path comprises at least two separate paths.

77. The piece of Ethernet terminal equipment of claim 1 wherein the at least one path comprises variable impedance.

78. The piece of Ethernet terminal equipment of claim 77 wherein the variable impedance comprises continuously variable impedance.

79. The piece of Ethernet terminal equipment of claim 1 wherein the piece of terminal equipment comprises an electrical component to change the at least one path.

80. The piece of Ethernet terminal equipment of claim 79 wherein the electrical component is responsive to an electrical condition across the contacts of the Ethernet connector.

81. The piece of Ethernet terminal equipment of claim 1 wherein the piece of Ethernet terminal equipment comprises an electrical component to change impedance of the at least one path.

82. The piece of Ethernet terminal equipment of claim 81 wherein the electrical component is responsive to an electrical condition across the contacts of the Ethernet connector.

83. The piece of Ethernet terminal equipment of claim 1 wherein the piece of Ethernet equipment comprises a controller.

84. The piece of Ethernet terminal equipment of claim 83 wherein the controller comprises firmware.

85. The piece of Ethernet terminal equipment of claim 53 wherein the controller comprises an integrated circuit.

86. The piece of Ethernet terminal equipment of claim 1 wherein the at least one condition is actually applied to the at least one of the contacts of the first and second pairs of contacts.

87. The piece of Ethernet terminal equipment of claim 1 wherein the at least one condition comprises a voltage condition between 3 and 20 volts DC.

88. The piece of Ethernet terminal equipment of claim 1 wherein the different magnitudes of DC current flow comprise a frequency.

89. The piece of Ethernet terminal equipment of claim 88 wherein the frequency is a fixed frequency.

90. The piece of Ethernet terminal equipment of claim 1 wherein the piece of Ethernet terminal equipment is physically connected to a network.

91. The piece of Ethernet terminal equipment of claim 57 wherein the predetermined range comprises impedance between 10 k ohm to 15 k ohm.

92. The piece of Ethernet terminal equipment of claim 1 wherein the piece of Ethernet terminal equipment to terminate the Ethernet communication signals.

93. The piece of Ethernet terminal equipment of claim 1 wherein the piece of Ethernet terminal equipment to originate the Ethernet communication signals.

94. The piece of Ethernet terminal equipment of claim 1 wherein the at least one path to protect the piece of Ethernet terminal equipment.

95. The piece of Ethernet terminal equipment of claim 94 wherein the at least one path is actually protecting the piece of Ethernet terminal equipment.

96. The piece of Ethernet terminal equipment of claim 94 wherein the at least one path to physically protect the piece of Ethernet terminal equipment.

97. The piece of Ethernet terminal equipment of claim 1 wherein the at least one path to protect the piece of Ethernet terminal equipment from unauthorized access.

98. The piece of Ethernet terminal equipment of claim 1 wherein the DC current to comprise a first magnitude of DC current for a first interval followed by a second magnitude of DC current for a second interval, wherein the first magnitude is greater than the second magnitude.

99. The piece of Ethernet terminal equipment of claim 1 wherein the piece of Ethernet terminal equipment comprises an isolation power supply.

100. The piece of Ethernet terminal equipment of claim 1 wherein the at least one of the magnitudes is actually conveying information about the piece of Ethernet terminal equipment.

101. The piece of Ethernet terminal equipment of claim 1 wherein the at least one of the magnitudes is actually conveying information about the piece of Ethernet terminal equipment via the contacts of the Ethernet connector.

102. The piece of Ethernet terminal equipment of claim 1 wherein a difference between at least two of the magnitudes to convey information about the piece of Ethernet terminal equipment.

103. The piece of Ethernet terminal equipment of any one of claims 1, 17, 18, 19, 21, 22, 31, 32, 46, 47, 67, 68, 85, and 86-89 and wherein the piece of Ethernet of terminal equipment is a piece of powered-off Ethernet terminal equipment.

104. A powered-off end device comprising:

an Ethernet connector comprising first and second pairs of contacts, at least one path for the purpose of drawing DC current, the at least one path coupled across at least one of the contacts of the first pair of contacts and at least one of the contacts of the second pair of contacts, the powered-off end device to draw different magnitudes of DC current flow via the at least one path, the different magnitudes of DC current flow to result from at least one condition applied to at least one of the contacts of the first and second pairs of contacts, wherein at least one of the magnitudes of the DC current flow to convey information about the powered-off end device.

105. The powered-off end device of claim 104 wherein the powered-off end device is a piece of terminal equipment.

106. The powered-off end device of claim 105 wherein the powered-off piece of terminal equipment is a piece of data terminal equipment.

107. The powered-off end device of claim 104 wherein the at least one condition comprises an impedance condition.

108. The powered-off end device of claim 104 wherein the at least one condition comprises a voltage condition.

109. The powered-off end device of claim 104 wherein the powered-off end device is physically connected to a central device.

110. The powered-off end device of claim 104 wherein the flow of DC current to indicate physical connection of the end device to a central device.

111. The powered-off end device of claim 104 wherein the information to distinguish the powered-off end device from at least one other end device.

112. The powered-off end device of claim 104 wherein the powered-off end device comprises an isolation power supply.

113. The powered-off end device of claim 104 wherein the information to identify the powered-off end device.

114. The powered-off end device of claim 104 wherein the at least one of the magnitudes is actually conveying information about the powered-off end device.

115. The powered-off end device of claim 104 wherein the powered-off end device is actually drawing the DC current via the at least one path.

116. The powered-off end device of claim 104 wherein the at least one condition is actually applied to the at least one of the contacts of the first and second pairs of contacts.

117. The powered-off end device of claim 104 wherein the at least one path comprises two separate paths.

118. The powered-off end device of claim 104 wherein the at least one path to protect the powered-off end device.

119. The powered-off end device of claim 118 wherein the at least one path to physically protect the powered-off end device.

120. The powered-off end device of claim 104 wherein the powered-off end device comprises an access control device.

121. The powered-off end device of claim 120 wherein the access control device comprises an alarm.

122. The powered-off end device of claim 104 wherein the at least one path is integrated into the powered-off end device. 5

123. The powered-off end device of claim 104 wherein at least one of the magnitudes is part of a detection protocol.

124. The powered-off end device of claim 104 wherein cessation in the flow of the DC current to indicate physical disconnection of the end device from a central device. 10

125. The powered-off end device of any one of claims 104 through 124 wherein the powered-off end device is a powered-off Ethernet end device.

* * * * *

15